

Installation Instructions

TGS03 Salt Spreader

Safety Precautions

WARNING

Observe the following Safety Precautions before, during and after operating this spreader. By following these precautions and common sense, possible injury to persons and potential damage to this machine may be avoided.

1. Read this entire Installation Instruction before operating this spreader.
2. Read all safety decals on the spreader before operating.
3. Verify that all personnel are clear of the spreader spray area before starting or operating this spreader.
4. Do not adjust, clean, lubricate or unclog material jams without first turning off the spreader.
5. Make sure the spreader is securely fastened to the vehicle in accordance with this manual.
6. Do not operate a spreader that is in need of maintenance or repairs.
7. Always disconnect the battery before removing or replacing electrical components.

Spreader Assembly

Check contents of box against parts list to make sure all components are included. When ordering replacement or spare parts refer to parts list for part numbers.



SPREADER WARRANTY

This warranty replaces all previous warranties and no employee of this company is authorized to extend additional warranties, or agreements, or implications not explicitly covered herein.

Buyers Products Company warrants all parts of the product to be free from defects in material and workmanship for a period of one (1) year. Parts must be properly installed and used under normal conditions. Normal wear is excluded.

Any part, which has been altered, including modifications, misuse, accident, or lack of maintenance will not be considered under this warranty.

The sole responsibility of Buyers Products Company under this warranty is limited to repairing or replacing any part(s), which are returned, prepaid, 30 days after such defect is discovered, and returned part(s) are found to be defective by Buyers Products Company.

Authorization from Buyers Products Company must be obtained before returning any part. The following information must accompany defective parts returned to Buyers Products Company: RMA #, spreader model, serial number, date installed, and distributor from whom purchased.

Buyers Products Company shall not be liable for damage arising out of failure of any unit to operate properly, or failure, or delay in work, or for any consequential damages. No charges for transportation or labor performed on any part will be allowed under this warranty.

1. Slide frame #3019400 into hitch receiver. Fig.1.

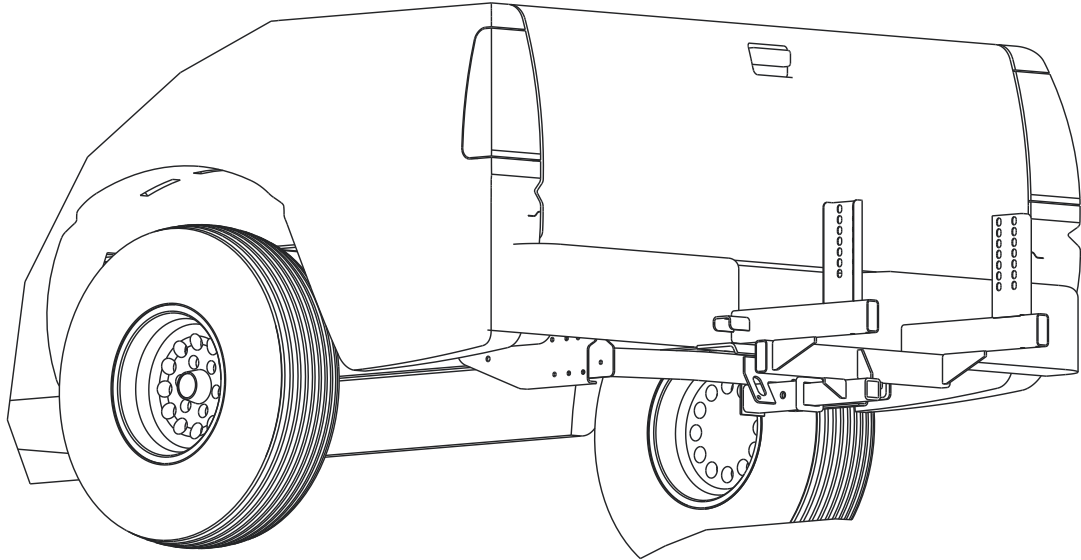

Fig. 1

2. Slide hopper assembly #3019372 between frame uprights with front portion rested on the truck's bumper. Fig.2.

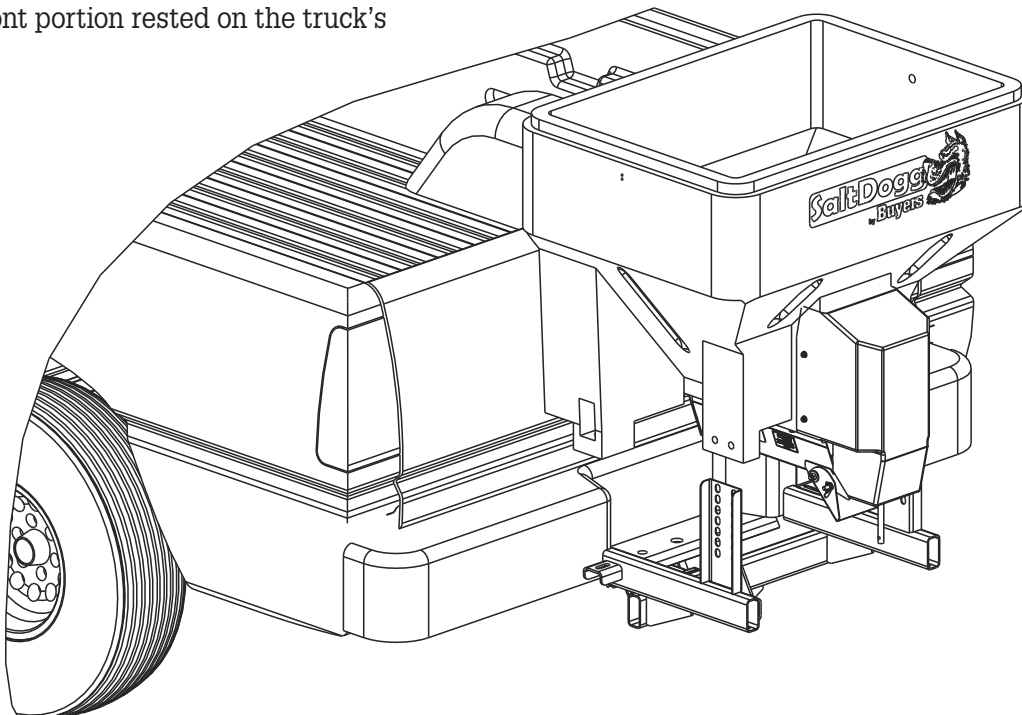

Fig. 2

3. Align holes in rear portion of the hopper with slots in frame uprights. Use slots which will position spreader with a slight upward tilt. Secure hopper assembly to frame using 1/2-13 x 3.0 screws, flat washers and nuts. Fig.3. Do not tighten fasteners at this time. Apply Antiseize on all stainless steel fasteners to avoid galling!

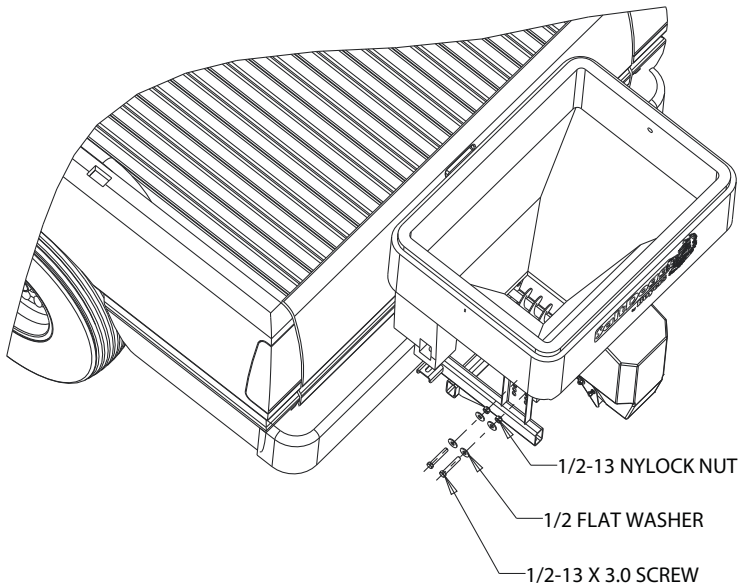

Fig. 3

WARNING
SPREADER CANNOT BE SUPPORTED BY FRAME ONLY!
SPREADER HOPPER MUST REST ON BUMPER OR SIMILAR STRUCTURE ATTACHED TO TRUCK FRAME.

5. Assembly 1/2-13 x 6.0 screws as shown in Fig.5. Make sure that nuts located between hopper flange and frame positioned exactly as shown. These nuts must not be in contact with hopper and frame at this time.

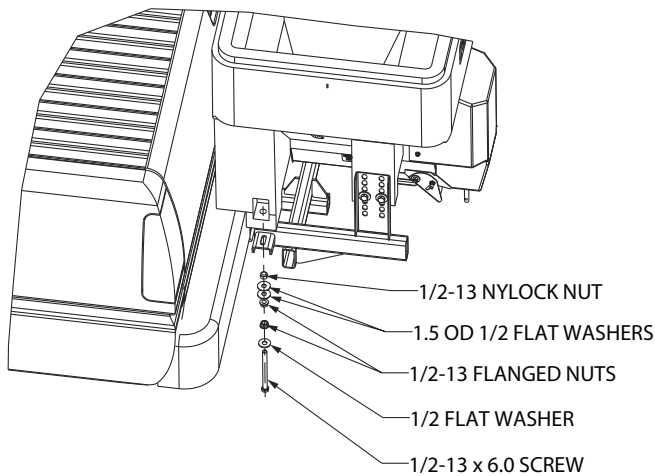

Fig. 5

4. Slide hopper and frame towards tailgate leaving about 3/8" to 1/2" space. Align closest holes in hitch receiver with holes in frame. Secure frame in hitch receiver using 5/8 hitch pin and cotter pin. Fig.4.

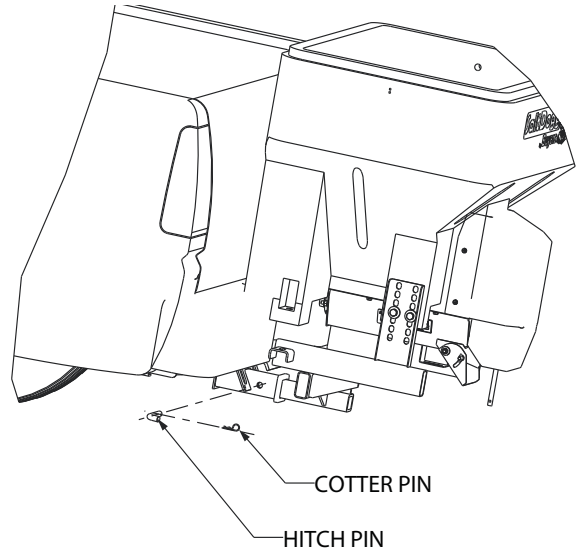

Fig. 4

6. Tighten nuts located in hopper pockets evenly on both sides of the spreader (10-15 ft-lb's. torque). Then tighten bolts in frame uprights. Finally tighten nuts located between hopper and frame. They must look as shown in Fig.6. After this procedure spreader should be securely attached to trucks bumper and frame.

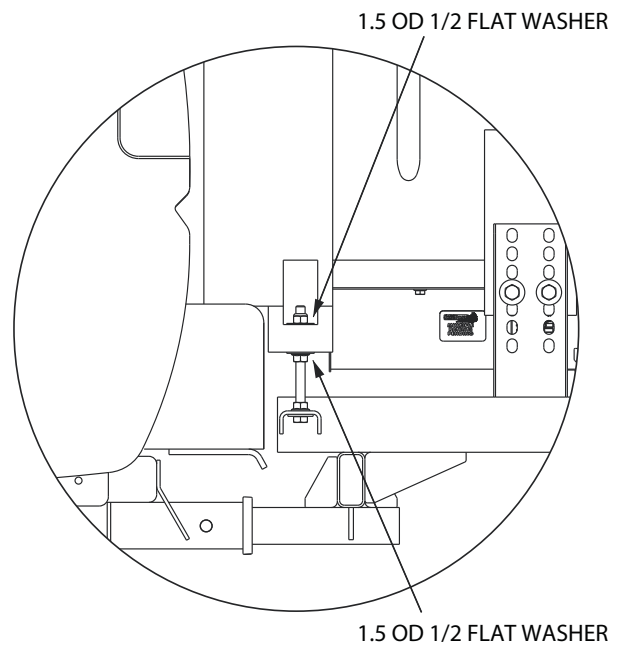
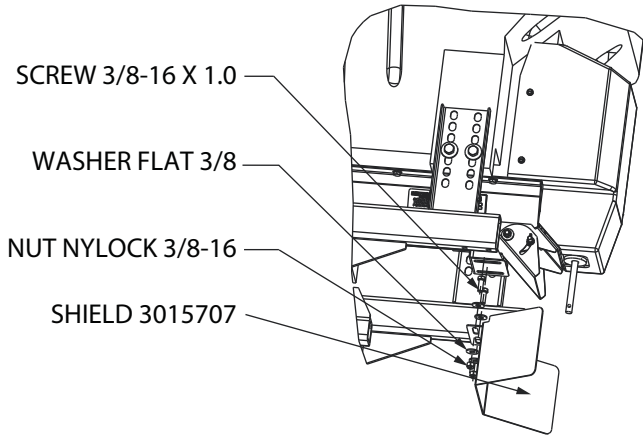

Fig. 6

7. Attach shield #3015707 to trough bracket as shown in Fig.7

Fig. 7



8. Attach spinner protector #3018923 to spreader frame as shown in Fig.8.

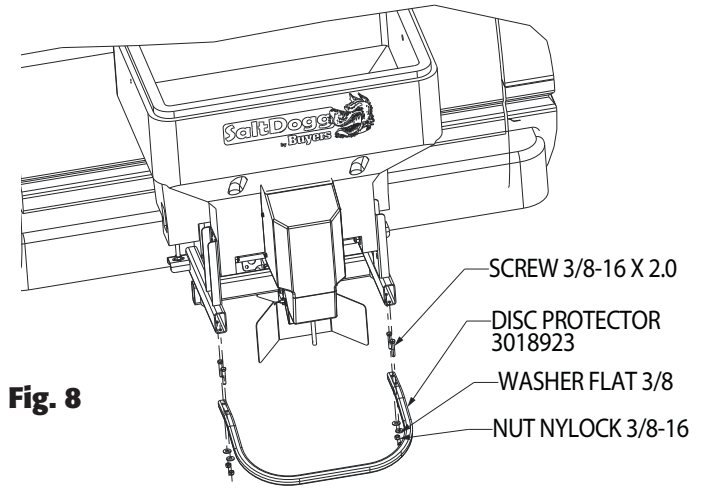
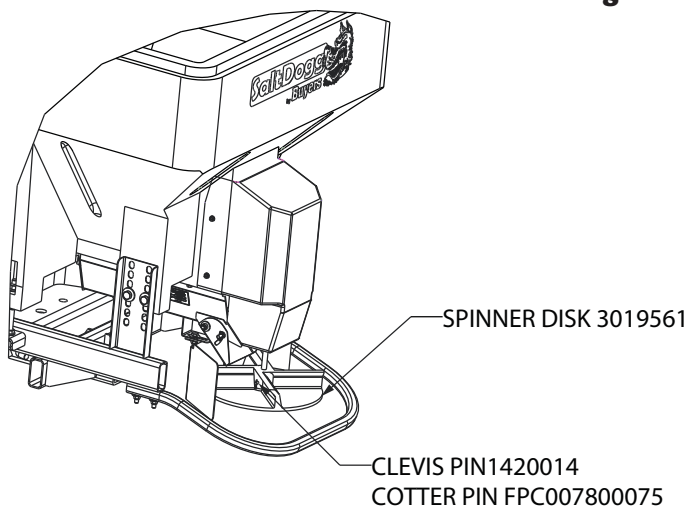

Fig. 8

9. Attach spinner disk to gear motor shaft as shown in Fig.9. Secure disk on shaft using clevis pin and cotter pin.

Fig. 9



10. Attach bracket and handle of draw latch to lid #3019410 using 2 10-24 screws as shown in Fig.10. Attach draw latch catcher to the hopper as shown in Fig.11.

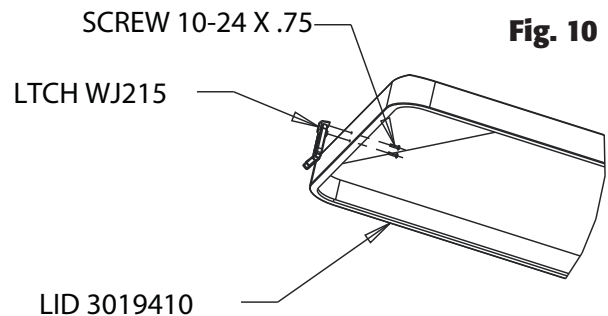

Fig. 10

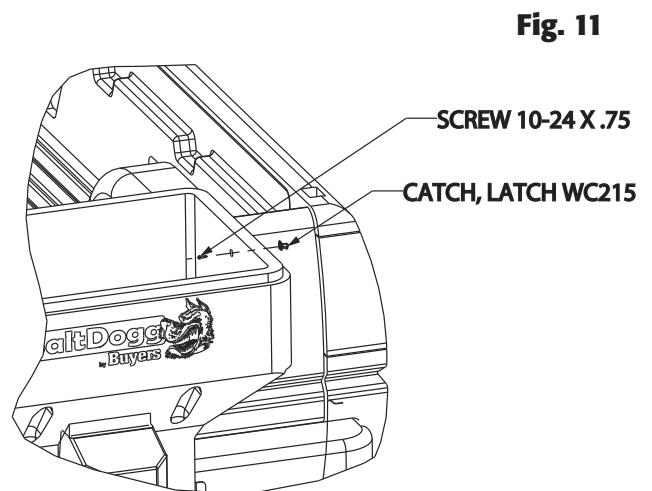

Fig. 11

**THIS IS WIRE GROUND ELECTRICAL SYSTEM!
NO CONNECTIONS TO TRUCK'S FRAME OR BODY
ALLOWED!**

NOTE: Always disconnect battery before attempting to install electrical components on your vehicle.

Mount the controller in a convenient location in the truck cab. It is recommended not to mount the controller directly in front of heat vents. Allow ample air space around controller.

CAUTION
DO NOT MOUNT CONTROLLER IN THE WAY OF AIR BAG DEPLOYMENT!

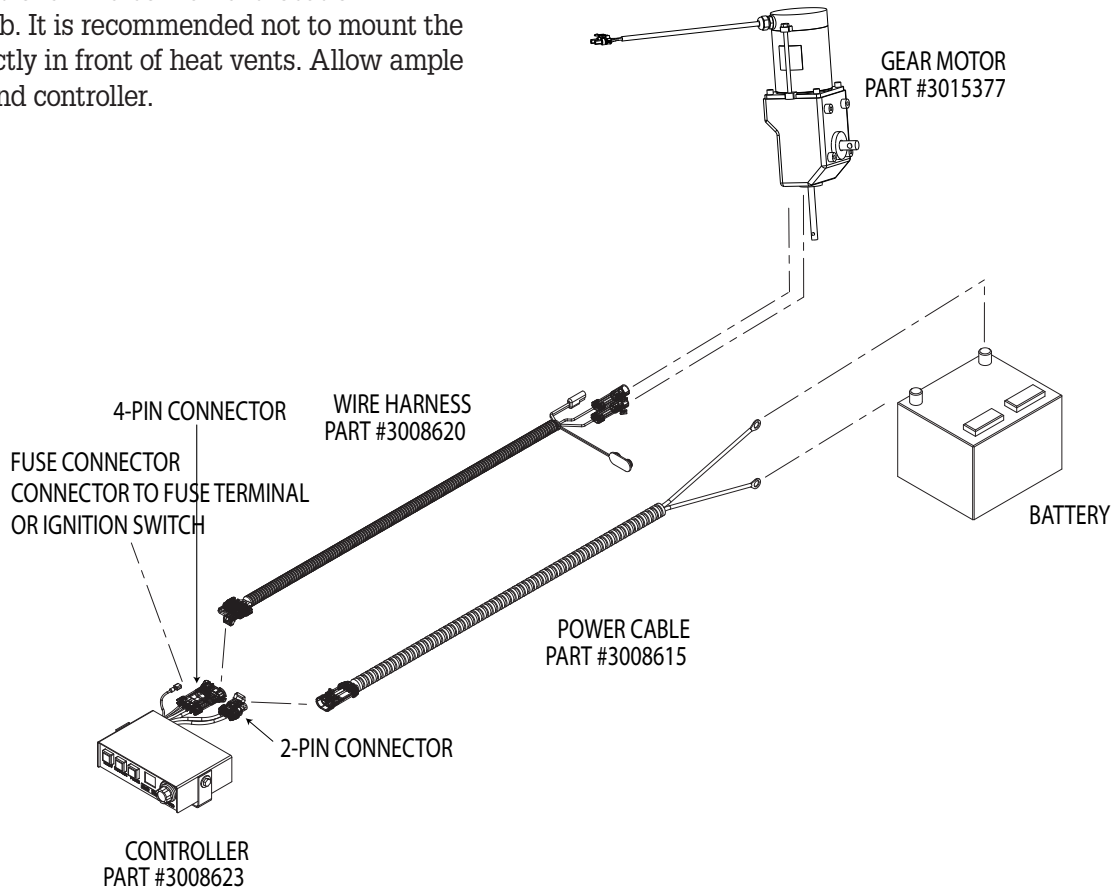

Installing Controller and Wiring

- Route both wire harnesses into truck cab through firewall (it maybe necessary to drill holes). Insulate hole to avoid water leaks.
- Insure no wires are nicked or damaged during installation.
- Connect the 4-pin connector on the wire harness to the control box.
- Connect the 2-pin connector on the power cable to the control box.
- Connect fuse connector to the fuse terminal or ignition switch.
- Lay out a path for the power cable to the battery, use quick ties to secure power cable.

DO NOT CONNECT TO BATTERY AT THIS TIME!

- Lay out path for wire harness to the rear of the vehicle. It is recommended to stay clear of the exhaust system. Excess heat can damage the wire harnesses. Use quick ties to secure harness to underbody.
- Connect the wire harness to the motor and vibrator.
- Connect the power and ground cables directly to the battery.
- Insure all functions of the controller are working properly.
- Note: direction of spinner may be changed by interchanging the motor leads.

Spreader Operation.

1. Due to the rate at which materials absorb moisture differently, some materials may not perform as desired. Therefore, the substitution of an alternative material may be necessary for optimum performance.
2. When filling hopper use supplied screen to prevent large chunks of material and debris contained in the material to get into hopper and cause operational problem or damage.
3. Material must never be left in the hopper for extended period of time. Material will absorb moisture, bind, harden and may prevent spreader from proper operation or may damage the spreader.
4. To start spreader make sure that truck engine is running. Flip POWER switch in ON position. Switch will illuminate. Spreader motor will accelerate to full speed and then it will slow down to previously dialed speed.
5. To adjust material flow rate and spreading distance, simply rotate speed knob to desired speed. Spreader can be put in full speed mode for short time by pressing and holding BLAST button.
6. To activate and deactivate vibrator press VIBRATOR button.
7. In addition material flow rate can be controlled by adjusting inverted vee, located inside hopper. To reduce material flow, lower inverted vee towards auger. For slow and difficult to flow materials inverted vee can be raised or completely removed.
8. In addition, material flow and pattern can be adjusted by opening/ close adjustable discharge on the trough bottom.

Optional vibrator installation.

To install optional vibrator, order vibrator #3007416 and plate #3017030. Drill 3/8 clearance holes thru hopper using bind holes as guides. Place plate inside hopper; align holes in plate with holes in hopper. Place vibrator on outer hopper wall and secure it to hopper using 4 carriage bolts 3/8-16 x 3.25 and 4 nylock nuts 3/8-16. Connect vibrator cable to mating connector on wire harness 3008620.

Check fasteners every 5-7 hours of operation. Retighten if necessary.

Controller Warnings.

Check controller instruction sheet for latest controller updates, troubleshooting codes. Controller instruction sheet is inside controller shipping box.

IMPORTANT! INSTALLER, DO NOT DISCARD CONTROLLER INSTRUCTION SHEET. STAPLE SHEET TO SPREADER MANUAL AND GIVE TO END USER!

Maintenance Instructions.

1. Wash spreader after every use. Make sure no material left under auger and/or inside trough.
2. Inspect and retighten fasteners after every 5-7 hours of operation.
3. Lubricate bearing every 7-10 hours of operation using general automotive grease.
4. Inspect terminals/ connectors every time you disconnect spreader from wire harness. Apply thin layer of dielectric grease on terminals. If any tarnish/corrosion found, clean terminals and apply dielectric grease.

End of Season Maintenance.

1. Wash spreader. Make sure no material or residue left in and outside hopper.
2. Lubricate bearing using general automotive grease.
3. Inspect wire harness, connectors for broken insulation, missing components. Replace if necessary.
4. Apply dielectric grease on all electrical connectors.
5. Store hopper indoors, in dry, cool place.
6. Inspect, clean and repaint frame.
7. Remove controller from truck. Store controller indoors, in dry, cool place.

TGS03 Tailgate Auger

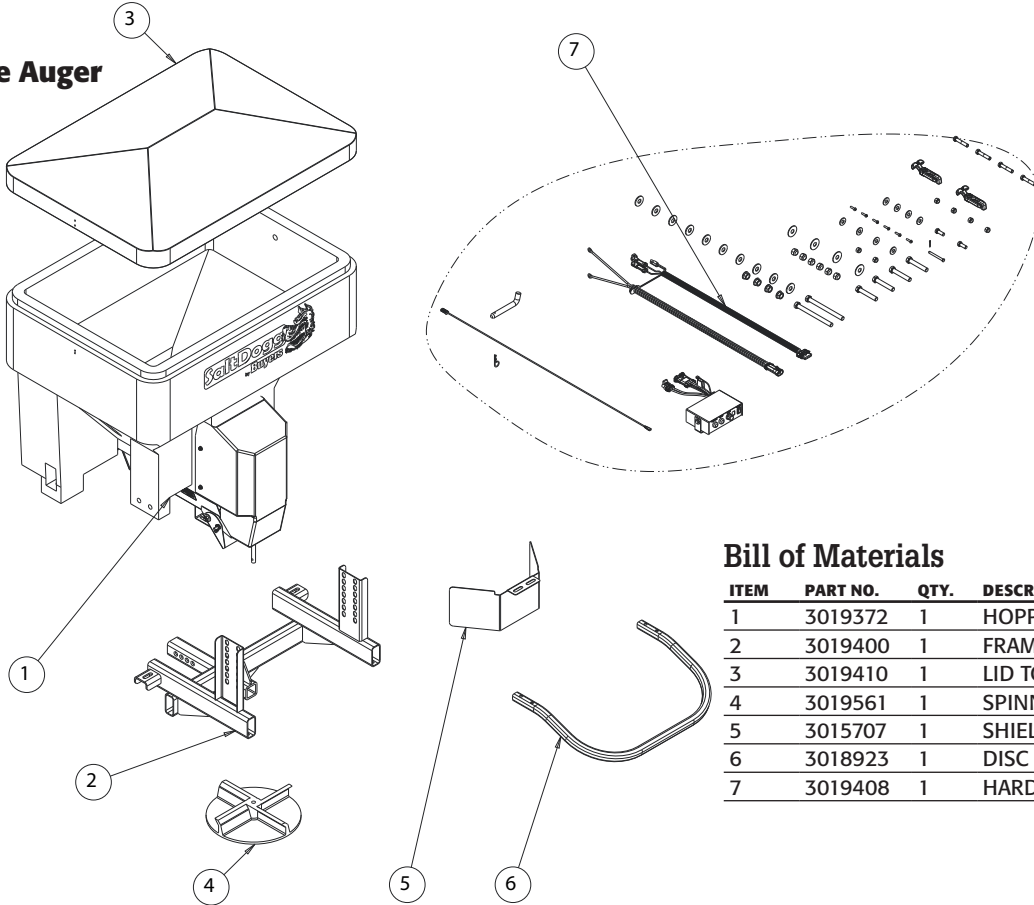

Bill of Materials

ITEM	PART NO.	QTY.	DESCRIPTION
1	3019372	1	HOPPER ASSEMBLY TGS03
2	3019400	1	FRAME TGS03
3	3019410	1	LID TGS03
4	3019561	1	SPINNER, 12 IN TGS
5	3015707	1	SHIELD TGS07
6	3018923	1	DISC PROTECTOR
7	3019408	1	HARDWARE BAG TGS03

TGS03 Hopper Assembly

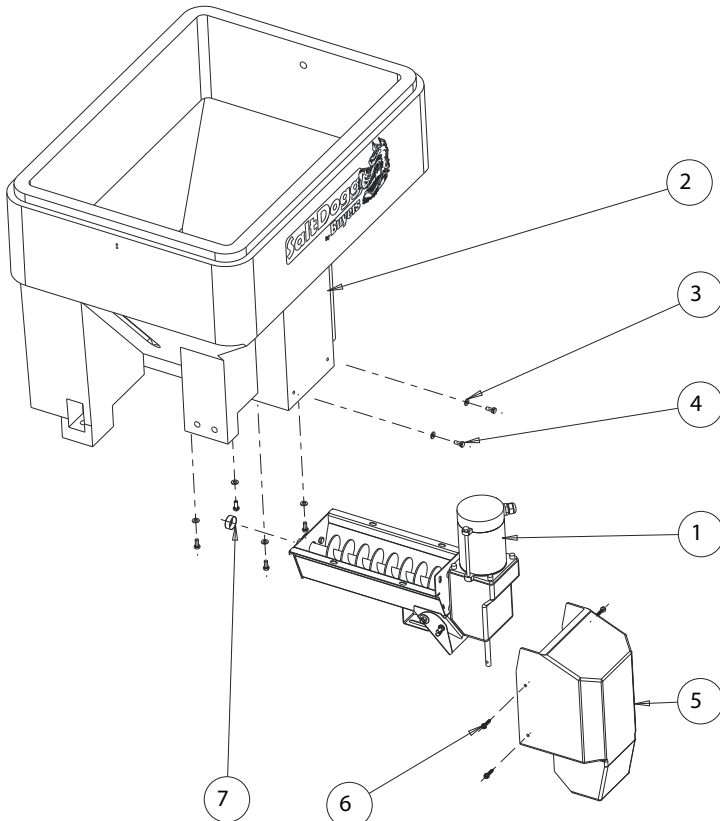

Bill of Materials

ITEM	PART NO.	QTY.	DESCRIPTION
1	3015383	1	TROUGH ASSEMBLY TGS07
2	3019471	1	HOPPER TGS03 POLY
3	FWF031075006SS	6	WASHER, 5/16 SAE SST
4	3006721	6	SCREW, HEX HD, 5/16-18 X 3/4 GR5 SS
5	3015694	1	MOTOR COVER TGS07
6	3015925	4	SCREW #14X1.25 SST
7	3017984	1	CAP ROUND 1.312 ID VINYL BLACK

TGS03 Trough Assembly

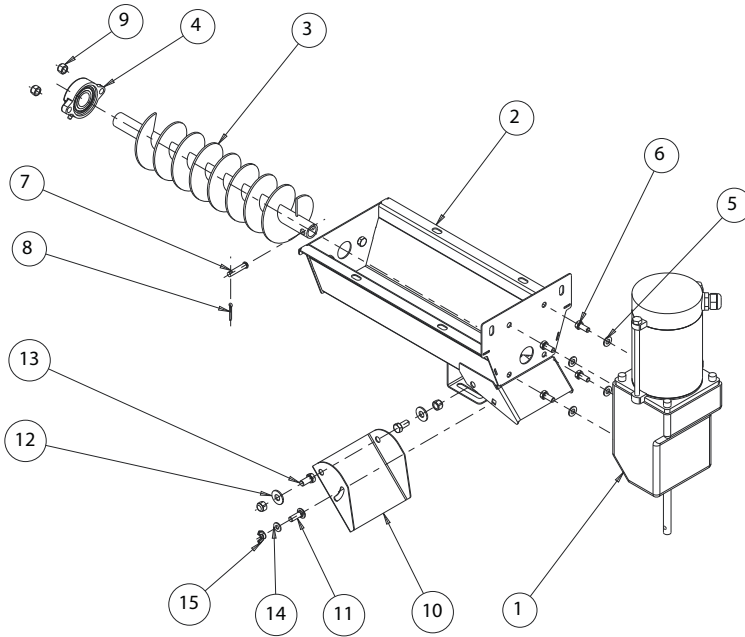

Bill of Materials

ITEM	PART NO.	QTY.	DESCRIPTION
1	3015377	1	GEAR MOTOR DUAL SHAFT .5 HP 12 VDC
2	3015381	1	TROUGH WELDMENT, TGS07
3	3015382	1	AUGER TGS07
4	1411000	1	BEARING, 2-HOLE FLANGED 1"
5	FWF031075006SS	4	WASHER, 5/16 SAE SST
6	3006721	4	SCREW, HEX HD, 5/16-18 X 3/4 GR5 SS
7	FPY031000150	1	PIN, CLEVIS, 5/16 X 1-1/2, W/ 5/32 PH, ZN
8	3014994	1	PIN, COTTER, 1/8IN X 1IN SST
9	FNE038016044SS	4	NUT, NYLOCK 3/8-16 X 7/16 SST
10	3019374	1	DISCHARGE, ADJUSTABLE
11	3012144	1	BOLT, RHSQN, .25-20X.5 SST
12	FWF038100007SS	2	WASHER, FLAT 3/8 USS SST
13	FCS038016075SS	2	SCREW, HHC-3/8-16 X 3/4 SST
14	FWF025063007SS	1	WASHER, FLAT 1/4 SAE SS
15	3016751	1	NUT, WING 1/4-20 SST

TGS03 Hardware Bag

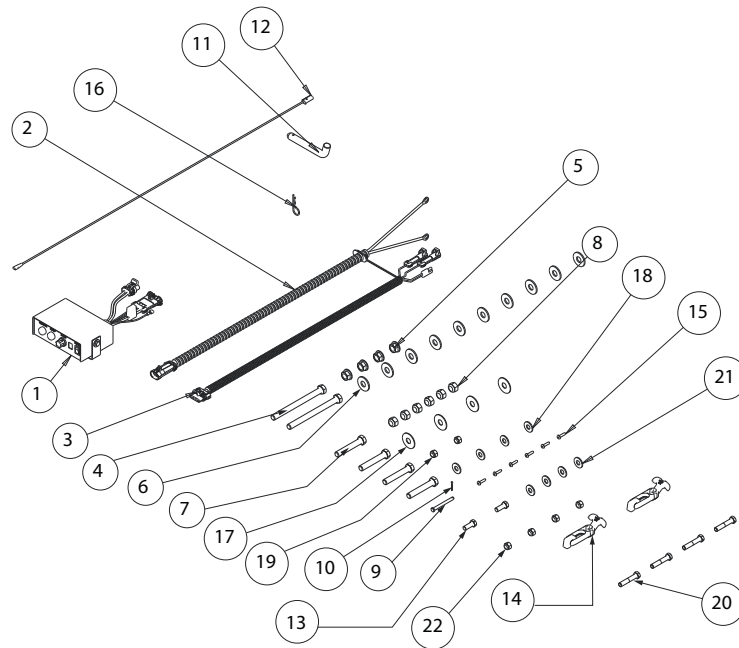

Bill of Materials

ITEM	PART NO.	QTY.	DESCRIPTION
1	3011864	1	CONTROLLER TGS W/ VIBRATOR SWITCH
2	3008615	1	WIRE HARNESS, POWER TGS
3	3008620	1	WIRE HARNESS MAIN W/ VIBRATOR, TGS
4	3017039	2	SCREW, HEX HEAD CAP 1/2-13 X 6.00 SST FULL THREAD
5	3001523	4	NUT, HX FLNG-1/2-13 SST
6	3000269	10	WASHER, FLAT 1/2 USS, SST
7	3001250	4	SCREW, HHC-1/2-13 X 3 SST
8	FNE050013053SS	6	NUT, NYLOCK 1/2-13 SS
9	1420014	1	PIN CLEVIS, 1/4 X 2.5
10	FPC007800075	1	COTTER PIN, 5/64 X 3/4
11	HP6253WC1	1	PIN, 5/8 HITCH
12	0203700	1	WIRE ASSEMBLY, 36 LONG

ITEM	PART NO.	QTY.	DESCRIPTION
13	FCS038016100SS	2	SCREW, HHC 3/8-16 X 1 304 SST
14	WJ215	2	LATCH DRAW RUBBER
15	FBSH01002475SS	6	SCREW, BHC #10-24 X .75 SST
16	1420016	1	PIN, HAIR COTTER, CLEAR ZINC
17	3017858	4	WASHER FLAT .5 ID 1.5 OD SST
18	FWF038100007SS	4	WASHER, FLAT 3/8 USS SST
19	FNE038016044SS	2	NUT, NYLOCK 3/8-16 X 7/16 SST
20	FCS038016200	4	SCREW, HHC 3/8-16 X 2 GR 5 ZP
21	FWF038100007	4	WASHER, FLAT 3/8 USS ZINC
22	FNE038016044	4	NUT, NYLOCK 3/8-16 X 7/16 ZINC
	3018421	1	ANTI SEIZE LUBRICANT POUCH 5 GRAM
	3019688	1	INSTRUCTION MANUAL TGS03