

Installation Instructions

SaltDog® Electric Drive Poly Hopper Spreader 6.0 cubic yards



Table of Contents

General Information	1
Safety Precautions	1
Installation Instructions	2-4
Spreader Operation	3-4
Spreader Maintenance	4
Repair Parts & Drawings	5-8
Warranty Information	8

General Information

Overall Length: 133.5 inches
 Overall Width: 77 inches
 Overall Height: 57 inches
 Empty Weight: 1,344 lbs
 Capacity Struck: 6.0 cu. yd.

Vehicle Requirements

Trucks with minimum GVWR 25,999 lbs.
 150 AMP or higher alternator is recommended.

Average Material Weights

<u>Materials to use</u>	<u>Weight (pounds per cubic yard)</u>
Fine Salt-Dry	2,250
Coarse Salt-Dry	1,431
Sand Coarse-Dry	2,565

Note: To calculate the total spreader weight (including ice control material), add the empty spreader weight plus the ice control material and spreader accessories.

WARNING

Improper installation and operation could cause personal injury, and/or property damage. Observe the following Safety Precautions before, during and after operating this spreader. By following these precautions and common sense, possible injury to persons and potential damage to this machine may be avoided.

CAUTION

Do not overload vehicle beyond the vehicle's GVWR or GAWR. Check vehicle's load rating certification sticker for maximum vehicle capacity.

Safety Precautions

1. Read this entire Owners Manual before operating this spreader.
2. Read all safety decals on the spreader before operating.
3. Check to make sure all safety guards are securely mounted into place before operating this spreader.
4. Verify that all personnel are clear of the spreader spray area before starting or operating this spreader.
5. Do not over-load your vehicle beyond payload limits. If there are any questions, contact the vehicle manufacturer.
6. Do not adjust, clean, lubricate or unclog material jams without first turning off the spreader.
7. Do not climb on or in the spreader during operation. Do not ride on the spreader while the vehicle is in motion.
8. Make sure the spreader is securely fastened to the vehicle in accordance with this manual.
9. Do not operate a spreader that is in need of maintenance or repairs.
10. Batteries normally produce explosive gases which can cause personal injury. Always disconnect the battery before removing or replacing electrical components.
11. Do not leave unused material in hopper. Material can freeze or solidify, causing spreader to not work properly, and/or damage the unit. Empty and clean after each use.

—continued inside

Installation Instructions

1. MOUNTING THE SPREADER ONTO THE VEHICLE:

- A.** Remove the tailgate from the vehicle (if equipped) as well as any other object which will interfere with the spreader.
- B.** Check truck's bed for all kinds of sharp debris or foreign objects. They can cut and seriously damage poly hopper.
- C.** Remove chute, hardware kit from inside spreader. If spreader has been used make sure there is no material left in the hopper.
- D.** Prepare 4 boards as shown in Fig. 1. A board size is 2" x 4" x 70" long minimum (cross boards from shipping pallet can be used). Boards can be as long as width of inside of trucks body.
- E.** Next, set the spreader in the truck body. Use four bars on the frame to lift the spreader (Fig. 1).

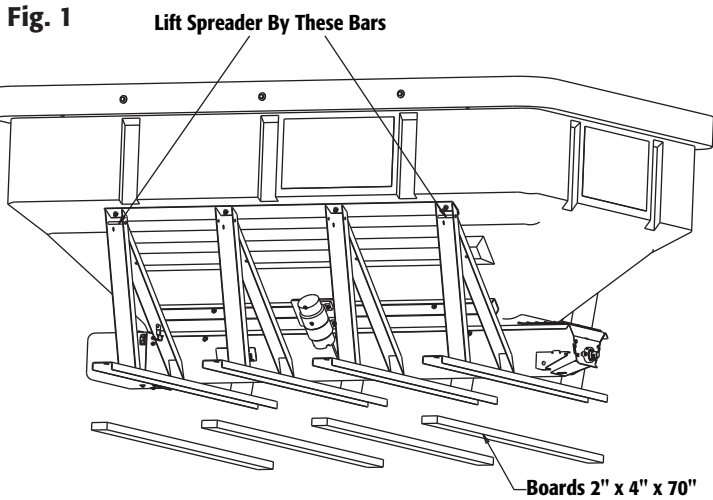

- F.** Lower spreader onto 2" x 4" boards positioned in truck bed. Attach chute to the spreader as shown in Fig.2

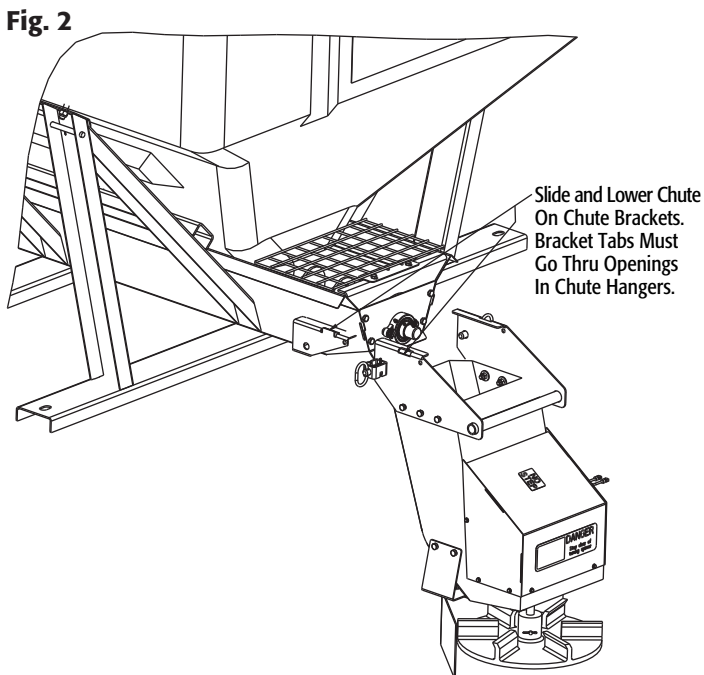

- G.** Secure chute in position using spring latches and clevis and hair pins as shown in Fig. 3.

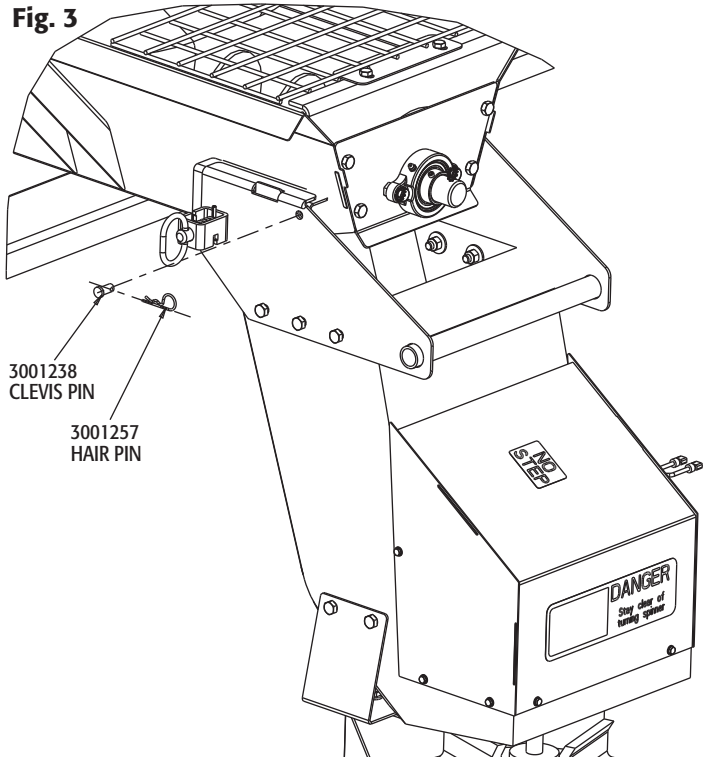

- H.** If necessary, slide spreader rearward to have at least 2" clearance between chute and rear most vertical obstruction.
- I.** Make sure the spreader is centered from side to side and rearmost board rests fully on trucks body.
- J.** Using holes in cross members fasten spreader to the vehicles body.

CAUTION
Never lift spreader with material in the hopper.

WARNING
Do not drill holes into fuel tanks, fuel lines, thru electrical wiring, etc that may be damaged by drilling.

CAUTION
Inspect straps and hardware after each time spreader is loaded. Tighten straps and hardware if necessary.

WARNING
Important! Do not use ratchet straps or tailgate latch exclusively! Always fasten spreader to the vehicle!

- K.** In addition, secure spreader using four ratchet straps attached to tie down bars on hopper frame or chain tie down kit (sold separately). Always tighten straps evenly!

2. CONTROL BOX AND VEHICLE WIRING HARNESS INSTALLATION

Make sure you have connected the proper wire color. **THIS IS WIRE GROUND ELECTRICAL SYSTEM! NO CONNECTIONS TO TRUCK'S FRAME OR BODY ALLOWED!**

NOTE: Always disconnect battery before attempting to install electrical components on your vehicle.

- A.** Mount the controller in a convenient location in the truck cab. It is recommended not to mount the controller directly in front of heat vents. Allow ample air space around controller.
- B.** Route both wire harnesses into truck cab through firewall (it maybe necessary to drill holes). Insulate hole to avoid water leaks.
- C.** Insure no wires are nicked or damaged during installation.
- D.** Connect the 4-pin connector on the wire harness to the control box 4-pin connector.

WARNING

Do not drill holes into fuel tanks, fuel lines, through electrical wiring, etc that may be damaged by drilling. To insure good performance of your spreader, check the condition of truck's electrical system. Using digital voltmeter, check alternator and battery voltage. With engine running and head lights and heater fan ON good voltage reading should fall between 13.0 and 15.3 volts. If voltage reading falls out of this range, check and adjust your electric system.

CAUTION

Do not mount controller in the way of air bag deployment!

IMPORTANT! Make sure all wires securely attached to vehicle or spreader. Use wire ties and/or wire clamps to attach wires. All excess wires must be rolled into bungles and attached to vehicle or spreader.

- E.** Connect the 2-pin connector on the power cable to the control box mating connector.
- F.** Connect wire harness single connectors to control box connectors.

G. Connect fuse connector to the fuse terminal or ignition switch (5 AMP max).

H. Lay out a path for the power cable to the battery, use quick ties to secure power cable.

DO NOT CONNECT TO BATTERY AT THIS TIME!

I. Lay out path for wire harness to the rear of the vehicle. It is recommended to stay clear of the exhaust system. Excess heat can damage the wire harnesses. Use quick ties to secure harness to underbody.

J. Connect the wire harness to the motors and vibrator. Make sure wire colors on wire harness match colors on the motor.

Thoroughly clean battery terminals. Make sure battery terminals have no tarnish or corrosion.

DO NOT CONNECT WIRE HARNESS TO DAMAGED OR CORRODED TERMINALS! IT MAY RESULT IN OVERHEATING, LOST POWER AND POTENTIAL CONTROLLER DAMAGE!

K. Connect the power cable directly to the battery.

L. Insure all functions of the controller are working properly.

M. Observe auger moving in proper direction. If direction is wrong reverse wires between Motor and Wire Harness.

N. Optional spot light (5 AMP max) can be installed on spreader. Remove cap from single white wire. Connect light to this wire and trucks frame.

Controller Connection (fig. 4)

A. SHPE6000 is equipped with a dual independent speed controller. To start spreader, press "POWER" switch. Switch will be illuminated. Auger and spinner will start rotating full speed for 2-3 sec then will slow down to originally dialed speeds. Auger and spinner can be adjusted independently.

Different materials and different moisture contents will affect spreader performance. In some cases material alternatives may be necessary.

B. To activate vibrator press "VIBRATOR" switch, vibrator switch will illuminate.

C. To stop spreader press "ON-OFF" switch again.

Fig. 4

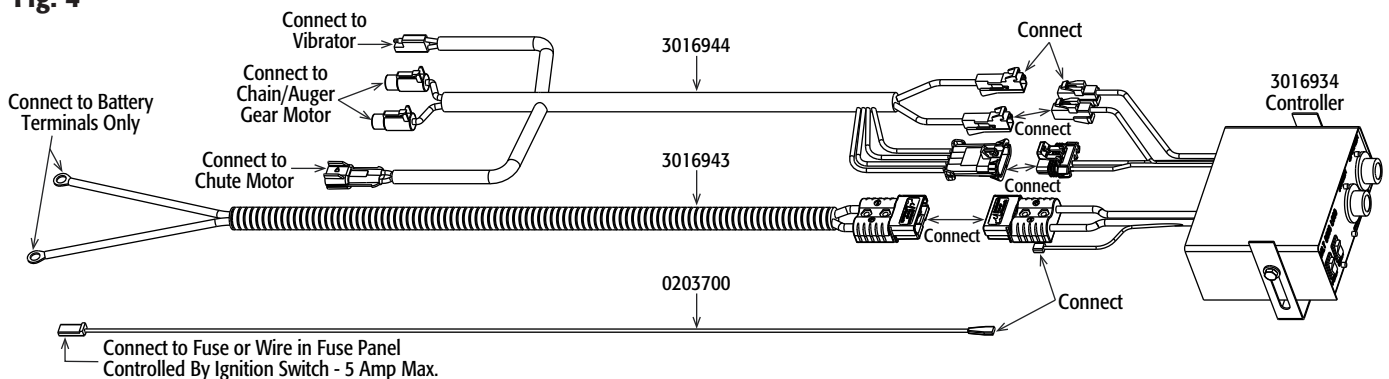

D. SHPE6000 controller is equipped with electronic overload and current spikes protection. Controller is not serviceable.

Controller has "Jam" light. If auger becomes jammed by chunk of material or foreign debris "Jam" light will be illuminated and controller will turn it self "OFF".

Controller can be restarted normally after jam removal. Controller is equipped with internal vibrator circuit breaker. Vibrator circuit breaker will trip and vibrator switch light will turn "OFF" if vibrator becomes overloaded. To reset vibrator circuit breaker turn vibrator switch off for 30 sec then turn it on again.

Vibrator can operate continuously for 30 min max with 15 min brakes to avoid overheating.

E. Spreading pattern can be controlled by repositioning of spinner shield on the shield bracket. Loose two screws and slide shield into desired position, then tighten screws.

Maintenance Instructions

A. Wash spreader after every use. Make sure no material left under auger and/or inside trough.

B. Inspect and retighten fasteners after every 10-15 hours of operation.

C. Lubricate bearing every using general automotive grease according to Fig.5

D. Inspect terminals/ connectors every time you disconnect spreader from wire harness. Apply thin layer of dielectric grease on terminals. If any tarnish/corrosion found, clean terminals and apply dielectric grease.

End of Season Maintenance.

A. Wash spreader. Make sure no material or residue left in and outside hopper.

B. Lubricate bearing using general automotive grease.

C. Inspect wire harness, connectors for broken insulation, missing components. Replace if necessary.

D. Apply dielectric grease on all electrical connectors.

E. Store hopper indoors, in dry, cool place.

F. Inspect, clean and repaint frame.

G. Remove controller from truck. Store controller indoors, in dry, cool place

WARNING
Never attempt to lift spreader with material in hopper!

WARNING
Never leave material in hopper for extended period of time. Material can freeze, solidify and seriously damage the spreader.

Fig. 5

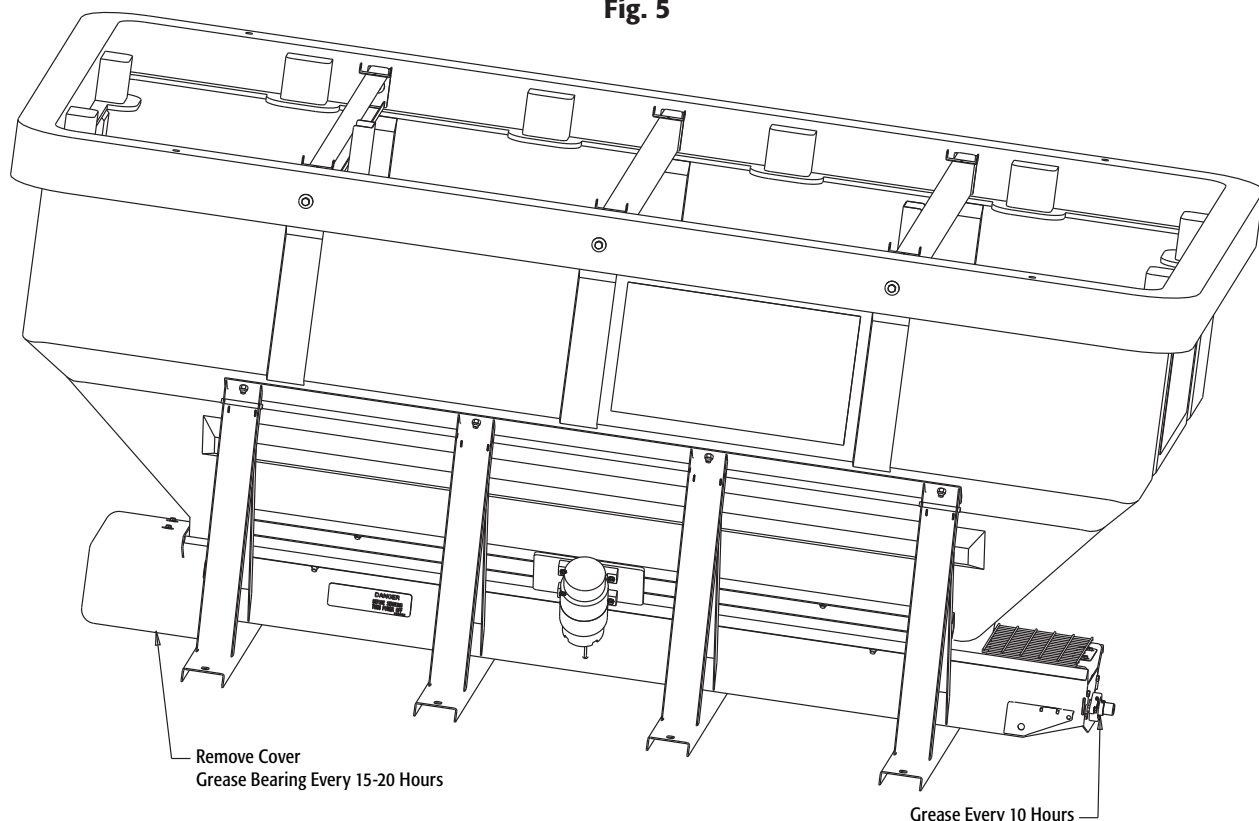

Chute Assembly

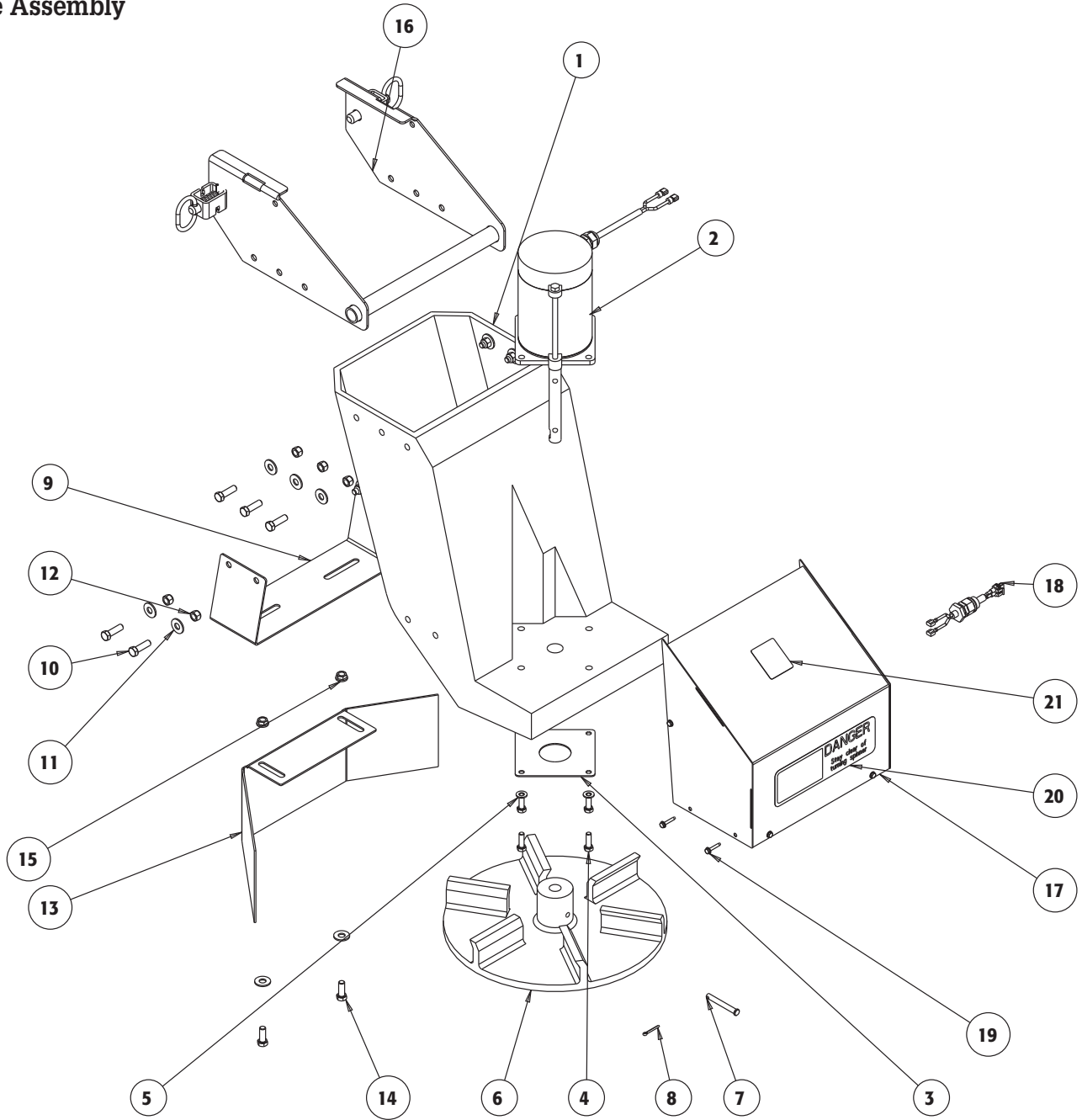

Bill of Materials

ITEM NO.	PART NO.	QTY.	DESCRIPTION
1	3012374	1	Chute, SHPE4000
2	3014078	1	Motor 12VDC, .5 HP Spinner
3	3012802	1	Retainer, Motor, Chute
4	-	4	Screw, HEX HD CAP 5/16-18 x 1.0 SST
5	-	4	Washer, 5/16 SAE SST
6	3012393	1	Spinner, 14" Poly CW
7	3007113	1	Pin, Clevis, 5/16 x 2-1/2, .141 Hole, ZN
8	-	1	Cotter Pin, 1/8 x 1, ZN
9	3012397	1	Bracket, Shield Chute
10	-	10	Screw, HHC 3/8-16 x 1.25 SST
11	-	12	Washer, Flat 3/8 USS SST

ITEM NO.	PART NO.	QTY.	DESCRIPTION
12	-	10	Nut, Nylock 3/8-16 x 7/16 SST
13	3012396	1	Shield Chute
14	-	2	Screw HHC 3/8-16 x 1, 304 SST
15	3001255	2	Nut, Hex Flange 3/8-16 SST
16	3019255	1	Chute Hanger Weldment
17	3012834	1	Cover Weldment, Chute
18	3006753	1	Wire Harness, Chute
19	-	8	Screw, Sheet Metal #12x1.0 Hex Washer HD SST
20	3007844	1	Decal, "DANGER STAY CLEAR"
21	3002631	1	Label, "NO STEP"

Hopper Assembly

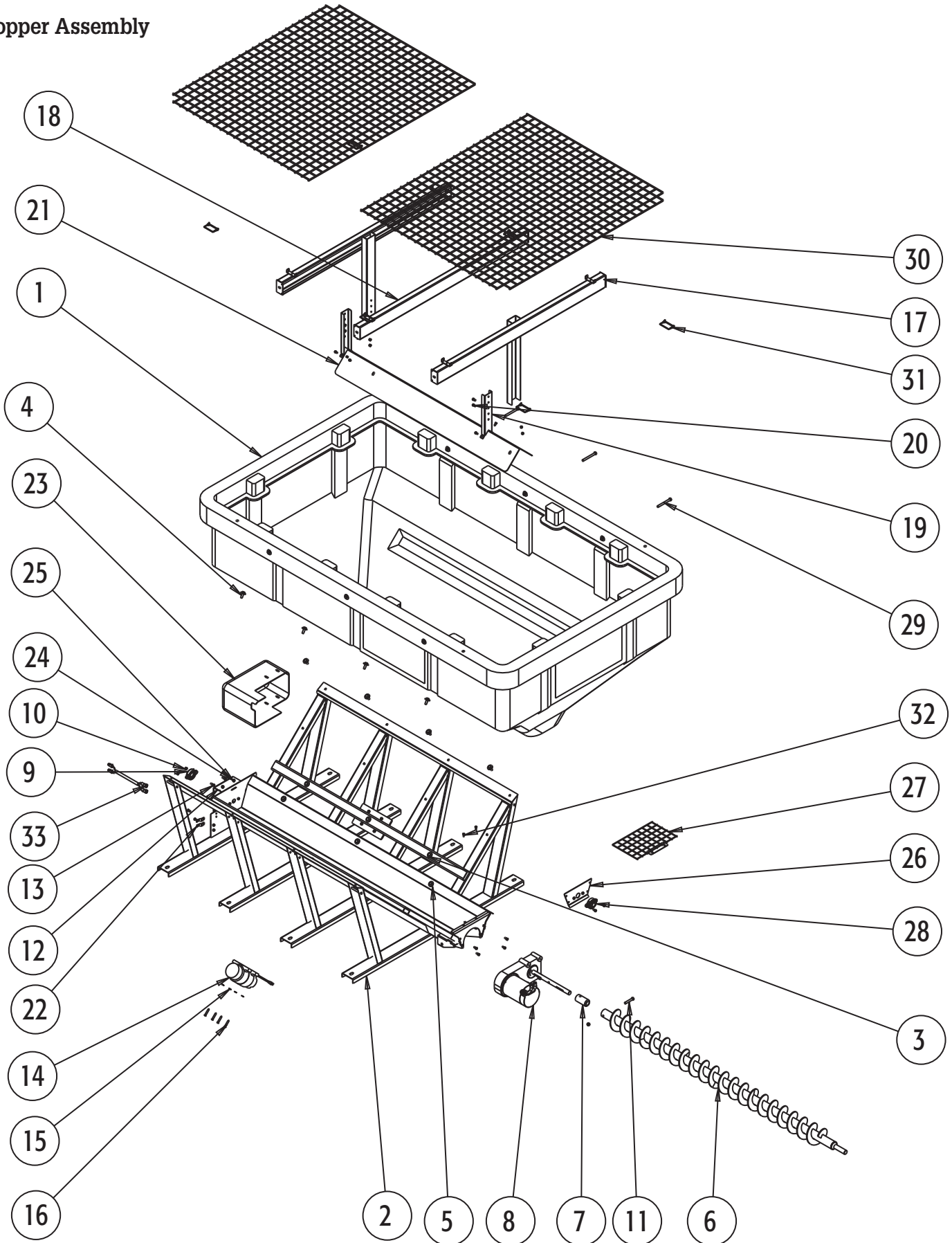

Hopper Assembly Bill of Materials

ITEM NO.	PART NO.	QTY.	DESCRIPTION
1	3018430	1	Hopper, Poly 6 cu.yd.
2	3018655	1	Trough Weldment SHPE6000
3	-	32	Washer, Flat .5 ID 1.5 OD SST
4	-	20	Screw, HHC 1/2-13x1.5 SST
5	-	27	Nut, Nylock 1/2-13 SS
6	3018639	1	Auger SHPE 6.0 x 4.0 RH
7	3014858	1	Sleeve Auger Adapter
8	3013821	1	Gear Motor Conveyor 12 VDC
9	1410200	1	Bearing, Flanged 1-1/8"
10	-	10	Nut, Nylock 3/8-16 x 7/16 SST
11	3001250	1	Screw, HHC 1/2-13 x 3 SST
12	-	4	Washer, Flat 3/8 USS SST
13	-	4	Screw, HHC 3/8-16 x 1 304 SST
14	3019166	1	Vibrator 900 lbs. 12 VDC
15	3017356	6	Washer, External Tooth Lock 3/8 SS
16	3007066	4	Screw, HHC 3/8-16 x 2 SST
17	3018855	2	Screen Bracket Weldment

ITEM NO.	PART NO.	QTY.	DESCRIPTION
18	3019795	1	Screen Support Weldment
19	3019163	2	Hanger, Inverted V
20	-	16	Screw, HHC 3/8-16 x 3/4 SST
21	3019164	1	Deflector, Inverted V
22	3017121	2	Bracket, Receptacle SZ8 Deutsch
23	3019236	1	Cover G Motor, Auger
24	-	4	Washer, 5/16 SAE SST
25	-	4	Screw, Hex HD CAP 5/16-18 x 1 SST
26	3019243	1	Bracket Bearing, Weldment
27	3019791	1	Auger Cover Weldment
28	9240086	1	Bearing, 1-1/4 Flange 2 Hole
29	-	6	Screw, Hex Head CAP 1/2-13 x 5 SST
30	3018857	2	Screen Mesh Half
31	66070	6	Snapper Pin, 1/4 x 3.5, Yellow ZN
32	-	2	Screw, Hex HD, 5/16-18 x 3/ Gr. 5 SS
33	3019878	1	Extension Wire Harness 8ft. Motor

SHPE6000 Assembly

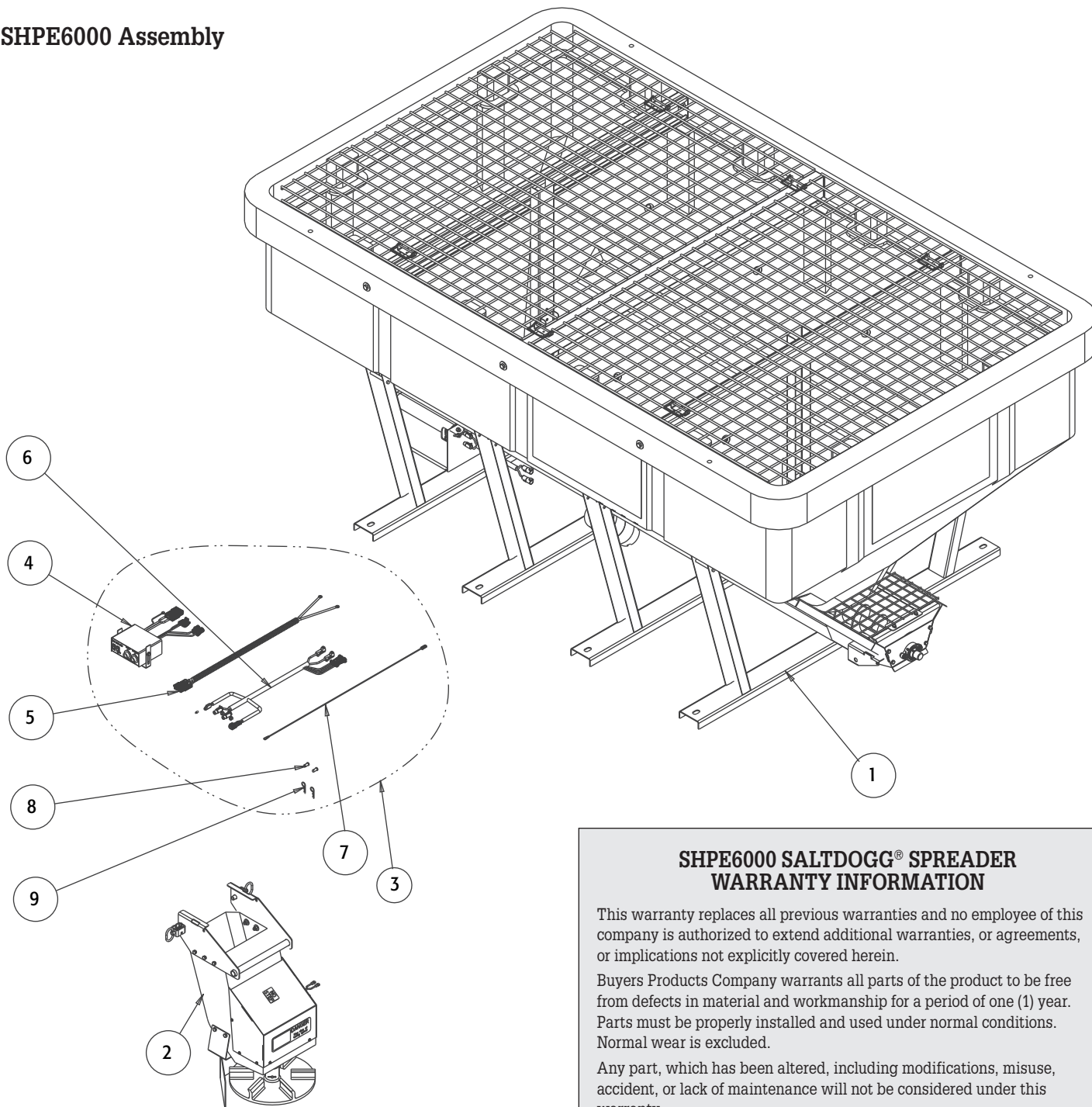

**SHPE6000 SALTDogg® SPREADER
 WARRANTY INFORMATION**

This warranty replaces all previous warranties and no employee of this company is authorized to extend additional warranties, or agreements, or implications not explicitly covered herein.

Buyers Products Company warrants all parts of the product to be free from defects in material and workmanship for a period of one (1) year. Parts must be properly installed and used under normal conditions. Normal wear is excluded.

Any part, which has been altered, including modifications, misuse, accident, or lack of maintenance will not be considered under this warranty.

The sole responsibility of Buyers Products Company under this warranty is limited to repairing or replacing any part(s), which are returned, prepaid, 30 days after such defect is discovered, and returned part(s) are found to be defective by Buyers Products Company.

Authorization from Buyers Products Company must be obtained before returning any part. The following information must accompany defective parts returned to Buyers Products Company: RMA #, spreader model, serial number, date installed, and distributor from whom purchased.

Buyers Products Company shall not be liable for damage arising out of failure of any unit to operate properly, or failure, or delay in work, or for any consequential damages. No charges for transportation or labor performed on any part will be allowed under this warranty.

Bill of Materials

ITEM NO.	PART NO.	QTY.	DESCRIPTION
1	3018639	1	Hopper Assembly, SHPE6000
2	3019256	1	Chute Assembly, SHPE6000
3	3021674	1	Hardware Kit, SHPE6000
4	3016934	1	Controller, Speed, 12 VDC, 60 AMP
5	3016943	1	Power Cord
6	3016944	1	Wire Harness Main
7	0203700	1	Wire Assembly, 36" Long
8	3001238	2	Pin, Clevis 3/8 x 3/4 w/ 1/8 Hole
9	3001257	2	Pin, Hair Cotter SS