

HONDA

Power

Equipment

Owner's Manual

SNOWBLOWER

HS1336i

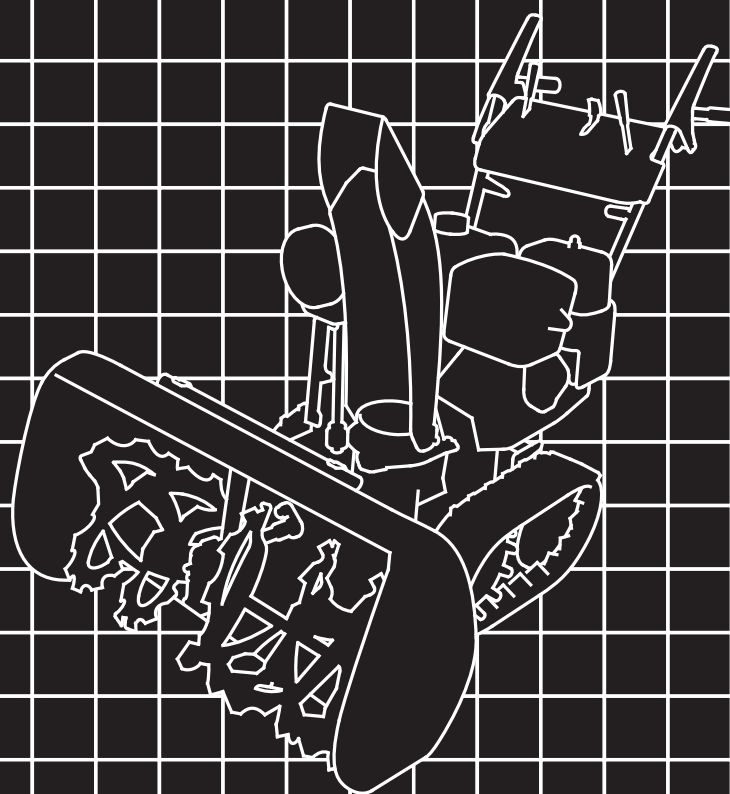



WARNING:



The engine exhaust from this product contains chemicals known to the State of California to cause cancer, birth defects or other reproductive harm.

Keep this owner's manual handy, so you can refer to it any time. This owner's manual is considered a permanent part of the snowblower and should remain with the snowblower if resold.

The information and specifications included in this publication were in effect at the time of approval for printing. Honda Motor Co., Ltd. reserves the right, however, to discontinue or change specifications or design at any time without notice and without incurring any obligation whatever.

INTRODUCTION

Congratulations on your selection of a Honda snowblower. We are certain you will be pleased with your purchase of one of the finest snowblowers on the market.

We want to help you get the best results from your new snowblower and to operate it safely. This manual contains the information on how to do that; please read it carefully.

As you read this manual, you will find information preceded by a **NOTICE** symbol. That information is intended to help you avoid damage to your snowblower, other property, or the environment.

We suggest you read the *Distributor's Limited Warranty* to fully understand its coverage and your responsibilities of ownership. The *Distributor's Limited Warranty* is a separate document that should have been given to you by your dealer.

When your snowblower needs scheduled maintenance, keep in mind that your Honda servicing dealer is specially trained in servicing Honda snowblowers. Your Honda servicing dealer is dedicated to your satisfaction and will be pleased to answer your questions and concerns.

Best Wishes,
Honda Motor Co., Ltd.

INTRODUCTION

A FEW WORDS ABOUT SAFETY

Your safety and the safety of others are very important. And using this snowblower safely is an important responsibility.

To help you make informed decisions about safety, we have provided operating procedures and other information on labels and in this manual. This information alerts you to potential hazards that could hurt you or others.

Of course, it is not practical or possible to warn you about all the hazards associated with operating or maintaining a snowblower. You must use your own good judgment.

You will find important safety information in a variety of forms, including:

- **Safety Labels** — on the snowblower.
- **Safety Messages** — preceded by a safety alert symbol  and one of three signal words, DANGER, WARNING, or CAUTION.

These signal words mean:

 **DANGER**

You WILL be KILLED or SERIOUSLY HURT if you don't follow instructions.

 **WARNING**

You CAN be KILLED or SERIOUSLY HURT if you don't follow instructions.

 **CAUTION**

You CAN be HURT if you don't follow instructions.

- **Safety Headings** — such as *IMPORTANT SAFETY INFORMATION*.
- **Safety Section** — such as *SNOWBLOWER SAFETY*.
- **Instructions** — how to use this snowblower correctly and safely.

This entire book is filled with important safety information — please read it carefully.

CONTENTS

SNOWBLOWER SAFETY	6
IMPORTANT SAFETY INFORMATION	6
SAFETY LABEL LOCATIONS	9
CONTROLS & FEATURES	11
COMPONENT & CONTROL LOCATIONS	11
CONTROLS	14
Engine Switch	14
Fuel Valve Lever	15
Manual Start Lever	15
Mode Selector Switch	16
Throttle Control Lever	19
Main Shift Lever	22
Drive Clutch Lever	23
Auger Clutch Switch	23
Steering Lever	24
Chute Control Switch	25
Auger Housing Control Switch	26
Reset Switch	27
FEATURES	28
Drive Control Warning Indicator (red)	28
Drive Control Warning Indicator (orange)	28
Charging Indicator	29
Oil Indicator	29
Battery Indicator	30
Fuel Gauge	31
Headlight	31
Wheel Pin	32
Snow Clearing Bar	33
Skid, Scraper	34
BEFORE OPERATION	35
ARE YOU READY TO GET STARTED?	35
IS YOUR SNOWBLOWER READY TO GO?	35
Check the General Condition of the Snowblower	36
Check the Engine	36
CHECK YOUR WORK AREA	37

CONTENTS

OPERATION	38
SNOWBLOWING PRECAUTIONS	38
STARTING THE ENGINE	39
OPERATING THE CONTROLS FOR CLEARING SNOW	42
Skid and Scraper	42
Auger Housing Height	45
Auger Housing Tilt Angle	47
Operation	48
Turning the Snowblower	58
Battery Run System	61
Auger Housing Reset Height Position	63
CLEARING SNOW	65
REMOVING OBSTRUCTIONS	68
STOPPING THE ENGINE	69
SERVICING YOUR SNOWBLOWER	73
THE IMPORTANCE OF MAINTENANCE	73
MAINTENANCE SAFETY	74
TOOL KIT	75
MAINTENANCE SCHEDULE	76
REFUELING	77
FUEL RECOMMENDATIONS	78
ENGINE OIL LEVEL CHECK	79
ENGINE OIL CHANGE	80
ENGINE OIL RECOMMENDATIONS	81
SPARK PLUG SERVICE	82
TRACK ADJUSTMENT	84
AUGER AND BLOWER INSPECTION	85
SHEAR BOLT REPLACEMENT PROCEDURE	86
AUGER/BLOWER REPLACEMENT	87
BATTERY SERVICE	88
Battery Electrolyte Level	89
Battery Removal/Installation	91
Battery Charging	94
FUSE	95

STORAGE	97
STORAGE PREPARATION	97
Cleaning	97
Fuel	100
Engine Oil	104
Battery	104
STORAGE PRECAUTIONS	105
REMOVAL FROM STORAGE	105
TRANSPORTING	106
BEFORE LOADING	106
LOADING	107
TAKING CARE OF UNEXPECTED PROBLEMS	109
ENGINE WILL NOT START	109
SELF-DIAGNOSIS FUNCTION	111
JUMP STARTING	122
EMERGENCY TRANSPORT	124
TECHNICAL INFORMATION	125
Serial Number Locations	125
Carburetor Modification for High Altitude Operation	126
Emission Control System Information	127
Air Index	129
Specifications	130
CONSUMER INFORMATION	131
Dealer Locator Information	131
Honda Publications	131
Customer Service Information	132
QUICK REFERENCE INFORMATION	Inside back cover

SNOWBLOWER SAFETY

IMPORTANT SAFETY INFORMATION

Honda snowblowers are designed to clear snow from driveways and walkways. Other uses can result in injury to the operator or damage to the snowblower and other property.

Most injuries or property damage with snowblowers can be prevented if you follow all instructions in this manual and on the snowblower. The most common hazards, are discussed below, along with the best way to protect yourself and others.

Avoid Rotating Impeller and Auger

Hand contact with the rotating impeller inside the discharge chute is the most common cause of injury associated with snowblowers. The snowblower auger can also cause serious injury. Keep away from the impeller and auger whenever the engine is running. If you need to work around the snowblower to clear snow for any reason, always shut off the engine. If the snow discharge chute becomes clogged, stop the engine and disconnect the spark plug cap. Use the snow clearing bar or a wooden stick to remove the obstructions. Never put your hand into the snow discharge chute while the engine is running; serious personal injury could result.

Clear Operation Area

The snowblower can throw rocks and other objects with enough force to cause serious injury. Before operating the snowblower, carefully inspect the area and remove any visible stones, sticks, bones, nails, pieces of wire, and other loose objects. Never use the snowblower to clear snow from a gravel road or driveway, as rocks may be picked up and ejected. They may cause injury to bystanders.

Keep Shields in Place

Guards and shields are designed to protect you from being hit by thrown objects and to keep you from touching hot engine parts and moving components. For your safety and the safety of others, keep all shields in place when the engine is running.

Adjust the snow discharge chute to avoid hitting the operator, bystanders, windows, and other objects with ejected snow. Stay clear of the snow discharge chute while the engine is running.

Children and pets must be kept away from the area of operation to avoid injury from flying debris and contact with the snowblower.

The muffler and engine become very hot during operation and remains hot for a while after stopping the engine. Be careful not to touch the muffler and engine while they are hot. Let the engine cool before storing the snowblower indoors.

Refuel with Care

Gasoline is extremely flammable, and gasoline vapor can explode. Allow the engine to cool if the snowblower has been in operation. Refuel only outdoors in a well-ventilated area with the engine OFF. Do not overfill the fuel tank. Never smoke near gasoline, and keep other flames and sparks away. Always store gasoline in an approved container. Make sure that any spilled fuel has been wiped up before starting the engine.

Turn Engine OFF When Not Operating the Snowblower

If you need to leave the snowblower for any reason, even just to inspect the area ahead, always turn the engine off.

Operation on Slopes

To avoid overturning, be careful when changing the direction of the snowblower while operating it on a slope. Do not use the snowblower to remove snow from roofs. The snowblower may overturn on steep slopes if left unattended, causing injury to the operator or bystanders.

SNOWBLOWER SAFETY

Operating Conditions

Do not use the snowblower when visibility is poor. Under conditions of poor visibility, there is a greater risk of striking an obstacle or causing injury. Adjust the snow discharge chute to avoid hitting passing bystanders or vehicles.

Stay clear of the snow discharge chute while the engine is running and be aware that loose clothing can get drawn into the moving parts.

Operating Near Roads

Always watch for vehicle traffic when operating the snowblower near roads and driveways.

Operator Responsibility

Know how to stop the snowblower quickly in case of emergency. Understand the use of all snowblower controls.

Never permit anyone to operate the snowblower without proper instruction. Do not let children operate the snowblower. If people or pets suddenly appear in front of the snowblower while it is in operation, immediately release the auger and drive clutch levers to stop the snowblower and avoid possible injury from rotating auger blades.

While operating the snowblower, hold the handle firmly and walk, don't run. Wear suitable winter boots that resist slipping.

Wear safety glasses or eye shields during operation to protect eyes from thrown objects.

Exercise caution on slippery surfaces to avoid falling, especially when operating in reverse.

SNOWBLOWER SAFETY

SAFETY LABEL LOCATIONS

These labels warn you of potential hazards that can cause serious injury. Read them carefully.

If a label comes off or becomes hard to read, contact your Honda dealer to purchase a replacement.

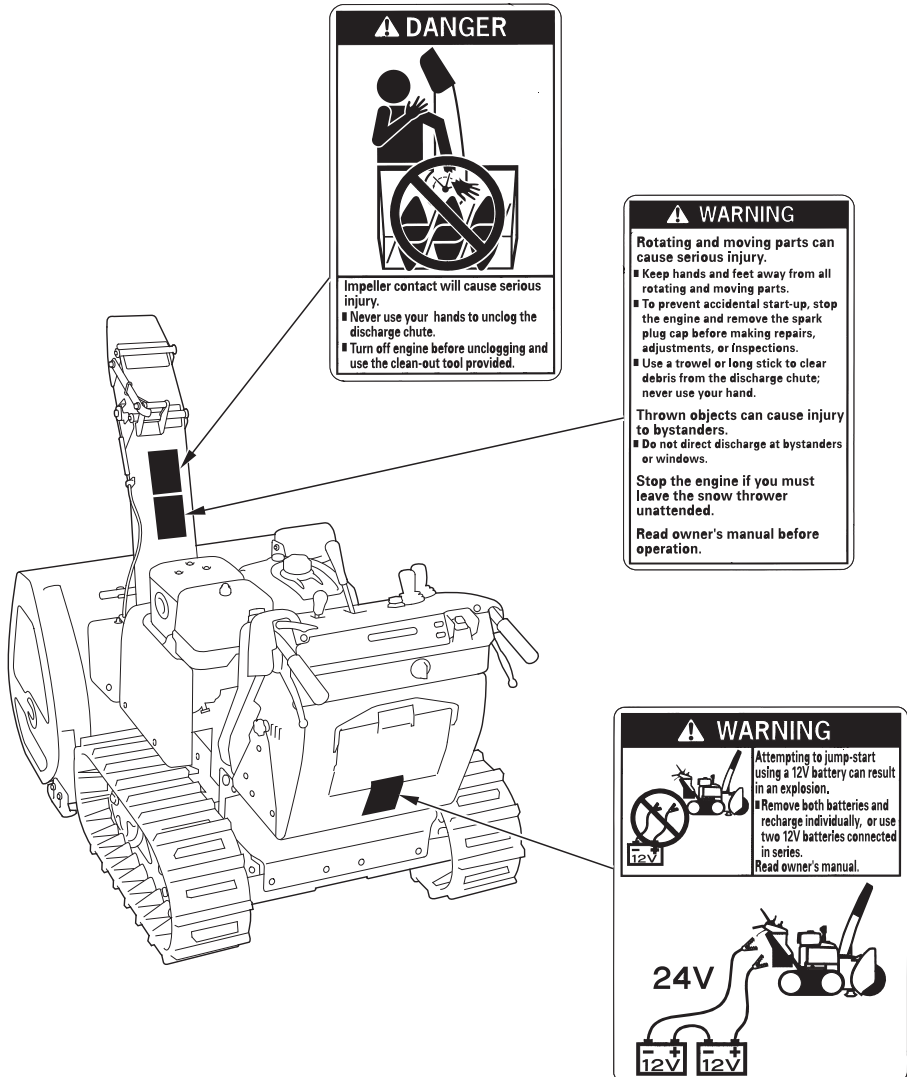

SNOWBLOWER SAFETY

⚠ DANGER

Rotating auger will cause serious injury.

- Keep hands and feet clear while engine is running.
- Turn off engine before unclogging and use the clean-out tool provided.

⚠ WARNING

Gasoline is highly flammable and explosive. Turn engine off and let cool before refueling.

The engine emits toxic carbon monoxide. Do not run in an enclosed area.

⚠ CAUTION

HOT MUFFLER CAN BURN YOU. Stay away if engine has been running.

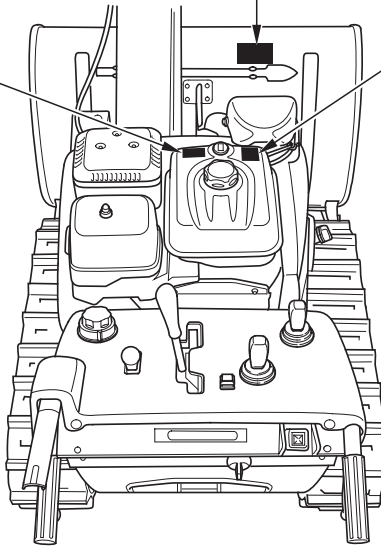

CONTROLS & FEATURES

COMPONENT & CONTROL LOCATIONS

Use the illustrations on these pages to locate and identify the most frequently used controls.

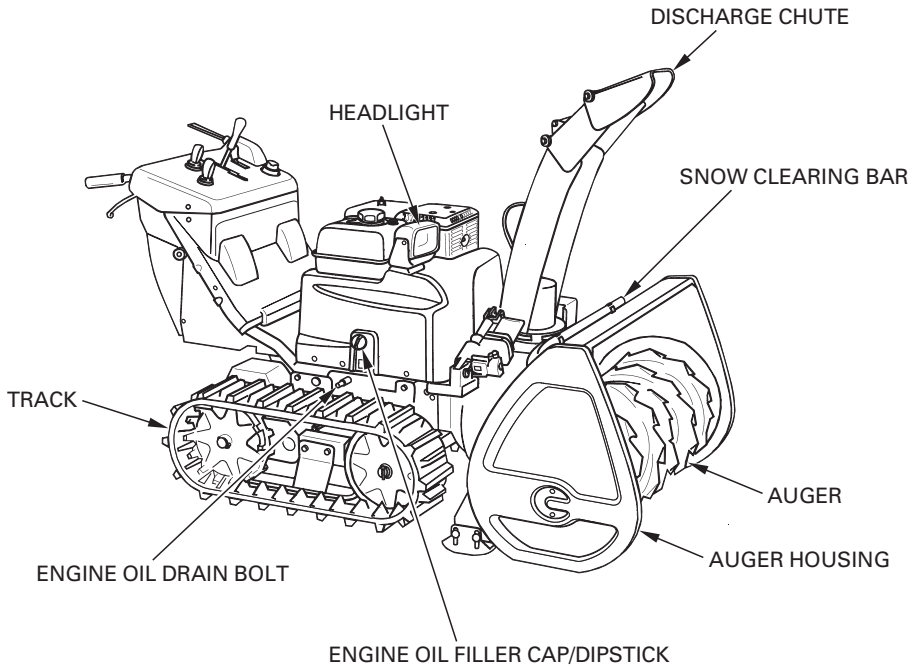

CONTROLS & FEATURES

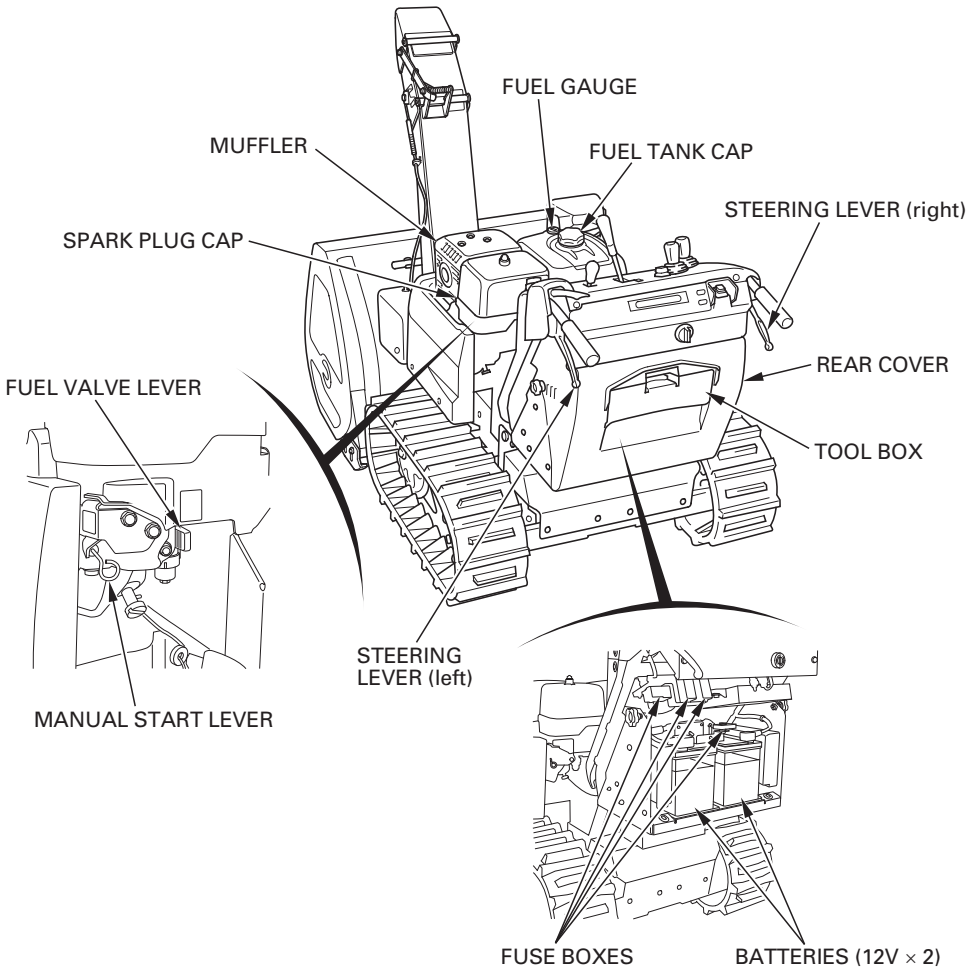

CONTROLS & FEATURES

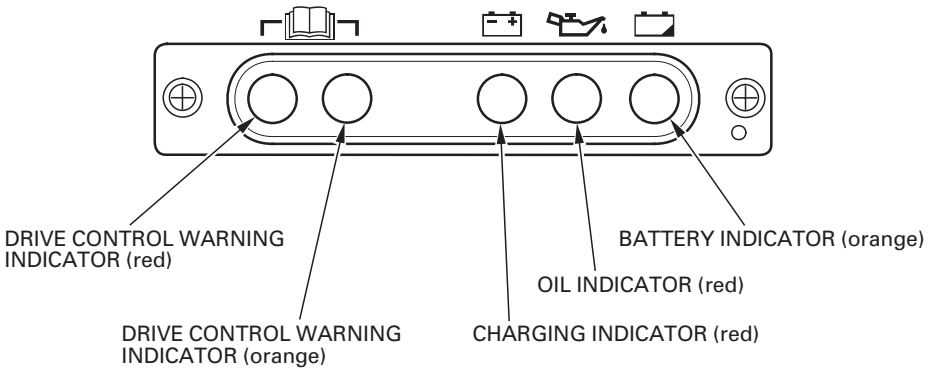
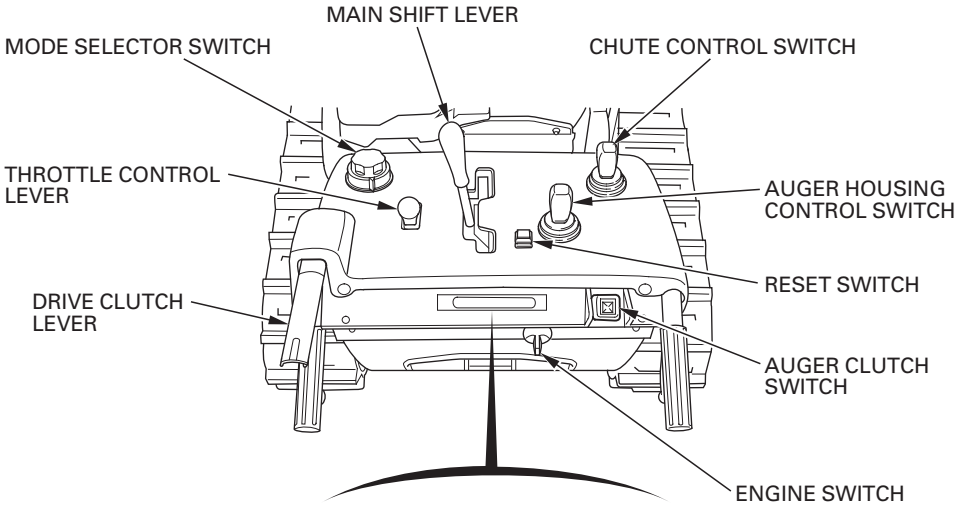

CONTROLS & FEATURES

CONTROLS

Engine Switch

The engine switch controls the ignition system. The key (if equipped) can only be inserted and removed when turned to OFF.

OFF — Engine switch position to stop the engine.

(The engine switch key can be removed/inserted with the switch in this position.)

ON — Engine switch position while the engine is running.

Each electric circuit comes on.

(It produces a clicking sound with the switch set in this position.)

START — Engine switch position to start the engine. The starter motor turns. Release the engine switch key, and the engine switch automatically returns to the ON position.

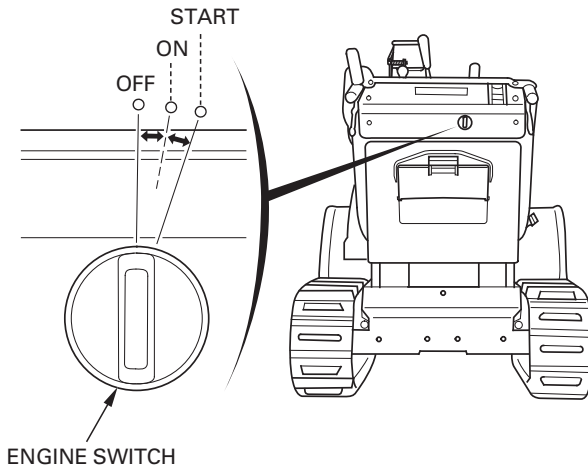

Fuel Valve Lever

The fuel valve opens and closes the fuel line leading from the fuel tank to the carburetor. Make sure that the fuel valve is positioned exactly at either the ON or OFF position. When the snowblower is not in use, always leave the fuel valve in the OFF position to reduce the possibility of fuel leakage.

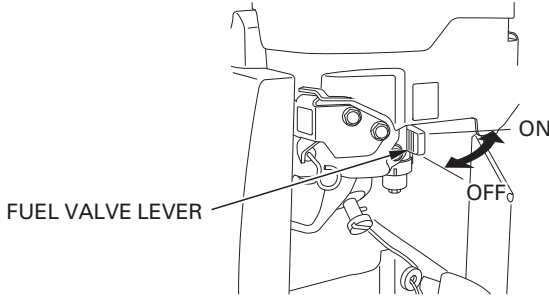

Manual Start Lever

This snowblower is equipped with the auto choke system. Do not need to operate the manual start lever to start using the normal starting. However, it may not function properly when foreign material (ice, etc.) is stuck on the system.

If the engine does not start after 5 attempts, push and release the manual start lever one time and try to start the engine (see page 40).

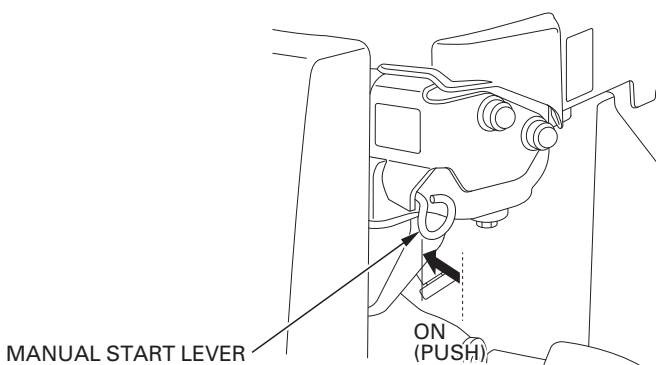

CONTROLS & FEATURES

Mode Selector Switch

Use the mode selector switch to change the work mode (automatic adjustment) of the snowblower. The work mode can be selected from one of three modes: AUTO, POWER, or MANUAL.

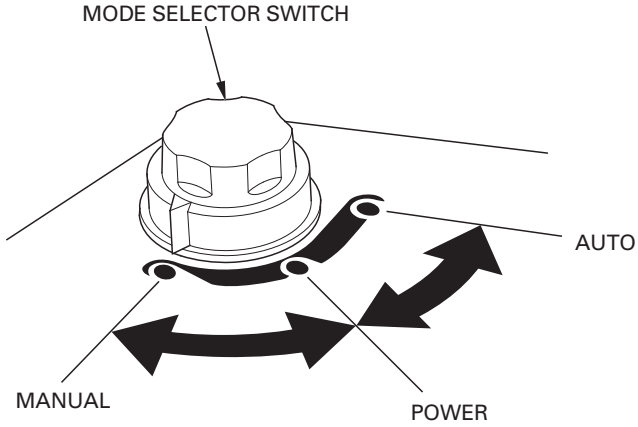

Characteristics of AUTO mode:

- Travel speed is automatically adjusted according to the workload, which reduces the tendency of snow to pile up in front of the snowblower.
- Engine speed is automatically adjusted according to operating conditions so the snow discharge distance remains constant.
- The auger is automatically raised when the snowblower is reversing. In case the auger clutch switch is in the ON position, the auger is automatically returned to the original position when the snowblower begins moving forward again.
- Forward speed is set low. Select another mode to make the snowblower travel faster.

Characteristics of POWER mode:

- Travel speed is automatically adjusted according to the workload so engine power can be maintained at or near the maximum level.
- Engine speed is automatically adjusted according to operating conditions so the snow discharge distance remains constant that have been set with the throttle control lever.
- The auger is automatically raised when the snowblower is reversing. In case the auger clutch switch is in the ON position, the auger is automatically returned to the original position when the snowblower begins moving forward again.

CONTROLS & FEATURES

Characteristics of **MANUAL** mode:

- No automatic adjustment is made. Manually adjust the engine speed and travel speed according to the workload.

NOTICE

Do not turn the mode selector switch to another position while the snowblower is moving. The electronic control unit will interpret this as a failure; the snowblower will stop moving and the auger will stop turning.

When the snowblower and auger stop moving/turning, move the main shift lever to the N (neutral) position, release the drive clutch lever once, and then squeeze it again.

Check each part to verify it is in its proper position before resuming operation.

Throttle Control Lever

Use the throttle control lever to adjust the engine speed and/or snow discharge distance with the mode selector switch set at the POWER or MANUAL position.

Note that the engine speed and snow discharge distance cannot be adjusted by operating the lever when the AUTO mode is selected.

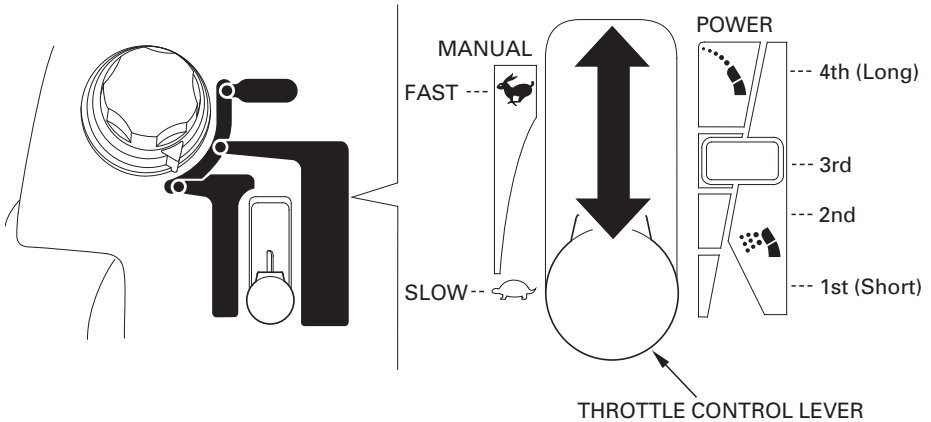

Moving the throttle control lever to the FAST side increases both the engine speed and snow discharge distance.

Moving the throttle control lever to the SLOW side decreases both the engine speed and snow discharge distance.

CONTROLS & FEATURES

POWER mode:

Travel speed is automatically reduced so that the engine speed and snow discharge distance are held at the given speed and distance that have been set with the throttle control lever.

Setting the discharge distance control lever in the second range from the bottom clears snow the fastest (maximum snow-clearing efficiency), but the snow discharge distance is shorter. Set the control lever in most appropriate engine speed and snow discharge distance for the work.

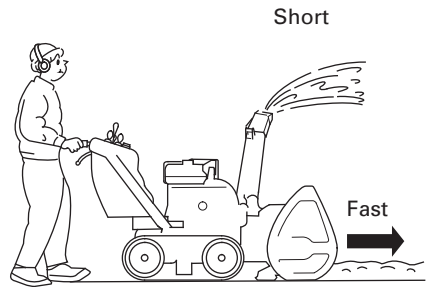
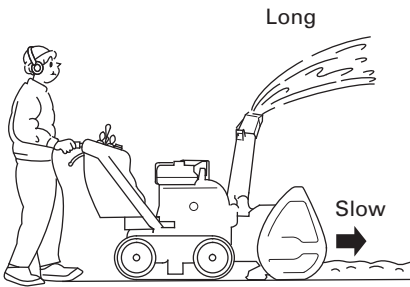
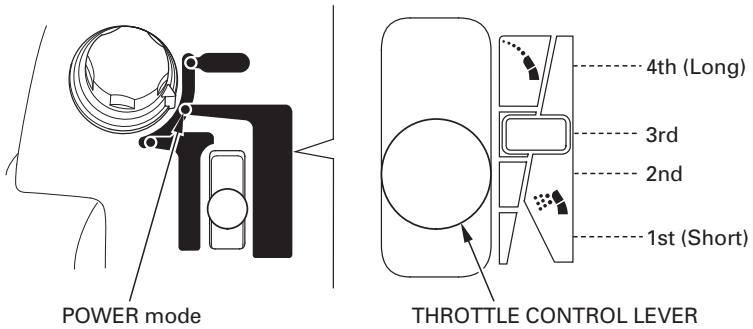

CONTROLS & FEATURES

MANUAL mode:

When the workload increases while clearing the snow, the engine speed and snow discharge distance drop below the given speed and distance that have been set with the throttle control lever. Reduce the workload applied to the snow clearing part of the snowblower to hold the engine speed/snow discharge distance at the given speed/distance. If you are not sure of the appropriate position to set the engine speed and snow discharge distance, we recommend that you set the control lever in the third position from the bottom (maximum power position). Then, adjust the snow discharge distance at the desired position while you are clearing the snow.

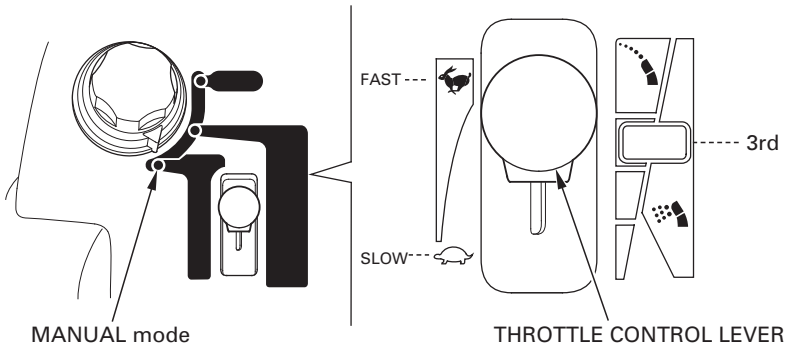

CONTROLS & FEATURES

Main Shift Lever

Operate the main shift lever to drive the snowblower in forward or in reverse direction.

The lever has two ranges, slow range and fast range.

The speed of the snowblower can be increased and decreased in any of these two speed ranges.

To drive forward:

Move the main shift lever slowly forward from the N (neutral) position.

To reverse:

Move the main shift lever slowly rearward from the N (neutral) position.

Set the main shift lever in the N (neutral) position while the snowblower is not in operation.

- Set the travel speed by setting the main shift lever to the desired position within the low speed range according to the nature of the snow, and clear the snow.
- Set the travel speed according to the road surface condition and environment before moving the snowblower.

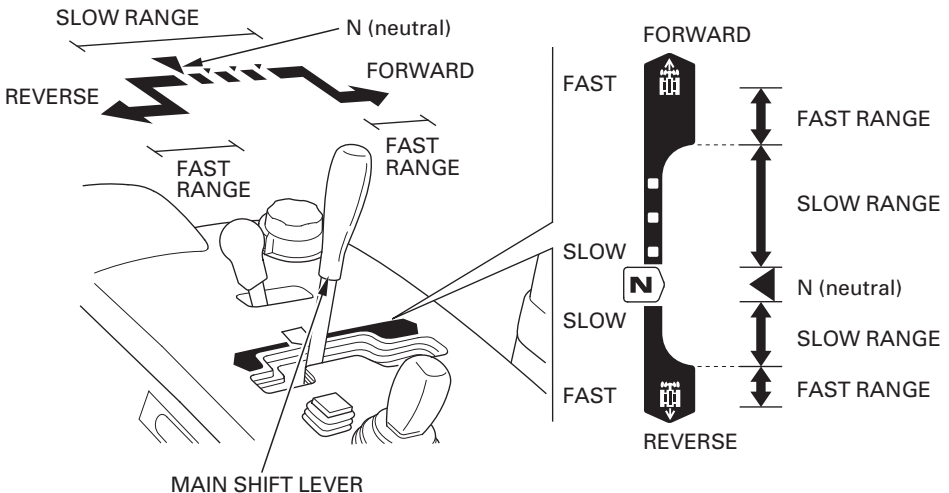

NOTICE

This snowblower has a function that limits the maximum speed in reverse. Consult to your authorized Honda snowblower dealer for details.

Drive Clutch Lever

Squeezing the drive clutch lever drives the snowblower forward or backward with the main shift lever operation.

If you are moving the snowblower from one place to another, squeeze the drive clutch lever only.

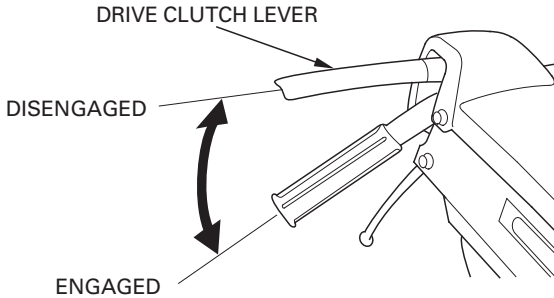

Auger Clutch Switch

If you continue pressing the auger clutch switch, the indicator comes on as a reminder and the snow blowing mechanism starts. Releasing the switch stops the mechanism and the indicator goes off. With the drive clutch lever squeezed, the auger clutch switch will be on continuously by pressing it once. Releasing the drive clutch lever stops the snowblower from moving and stops the auger.

- If the indicator (green) does not come on and neither the auger nor blower turns by pressing the auger clutch switch, have your authorized Honda snowblower dealer check the snowblower.
- Both the auger and blower stop turning by pushing the auger clutch switch for 4 seconds or more.

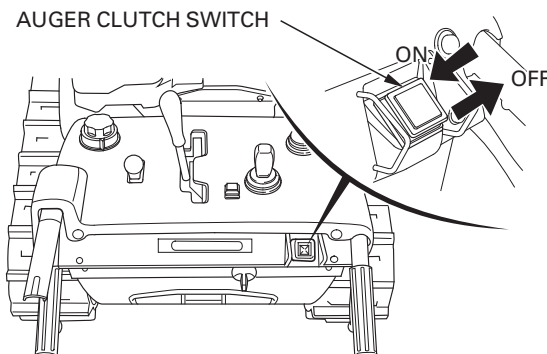

CONTROLS & FEATURES

Steering Lever

Use the steering lever to turn the snowblower.

Squeeze the steering lever on the side to which you want to turn the snowblower. Note that the radius of turn can be adjusted depending on a position of the main shift lever and the amount of squeeze of the steering lever.

To turn to the right: Squeeze the right steering lever.

To turn to the left: Squeeze the left steering lever.

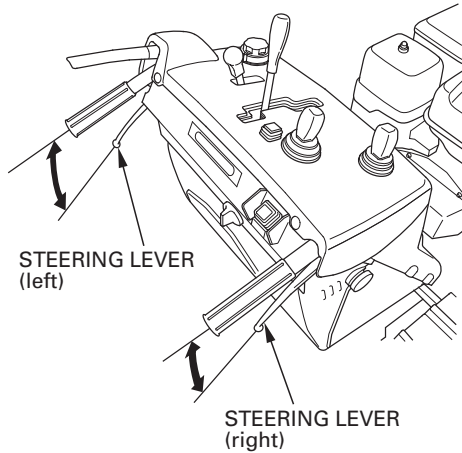

⚠ CAUTION

- Reduce speed when making turns. Use extra care when making turns as the location of the handle and panels relative to the operator will change suddenly and can cause injury.
- Note that the road condition (e.g. asphalt road, covered with snow, slope, bumpy surface, etc.) can affect the radius of turn and your steering feel.

Chute Control Switch

The snow discharge direction and angle can be adjusted by operating the chute control switch.

Turn the engine switch to the ON position and operate the chute control switch to adjust the snow discharge direction and angle up/down or right/left (see pages 49, 52 and 55).

Operate the chute control switch while the engine is running.

Operating the chute control switch while the engine is OFF may cause a dead battery.

- Do not keep operating the chute control switch with the chute/chute guide motor locked. The protection function gets armed, preventing the chute from moving. Wait a few minutes before operating the chute control switch again.

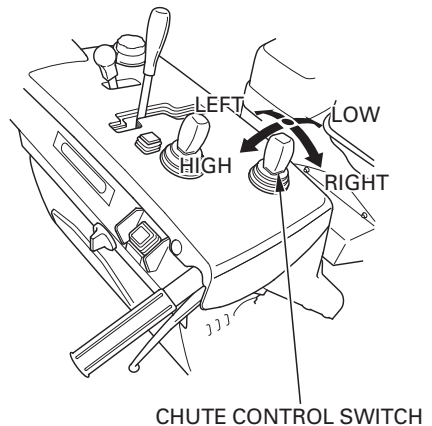
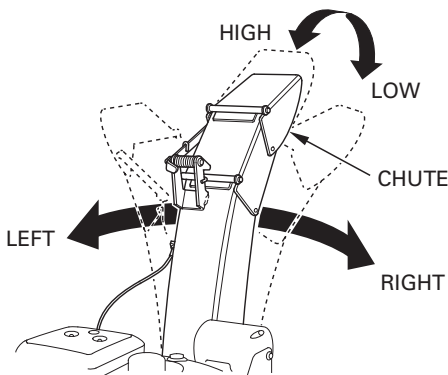

⚠ CAUTION

Adjust the snow discharge direction and angle with care not to hit bystanders, windows, and other objects with thrown snow.

CONTROLS & FEATURES

Auger Housing Control Switch

Operate the auger housing control switch to adjust the auger housing height and tilt angle (see pages 45 and 47 for adjustment). Operate the auger housing control switch while the engine is running. Operating the auger housing control switch while the engine is OFF may cause a dead battery.

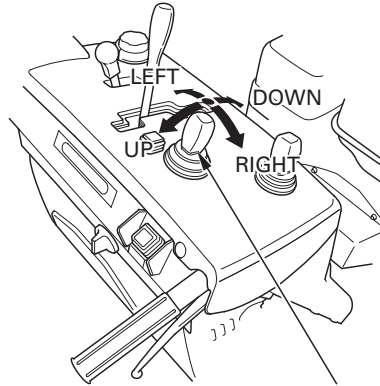

AUGER HOUSING CONTROL SWITCH

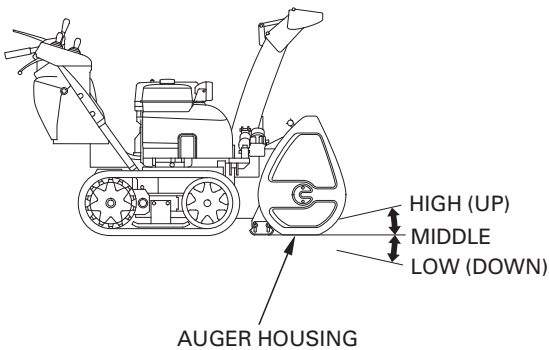

AUGER HOUSING

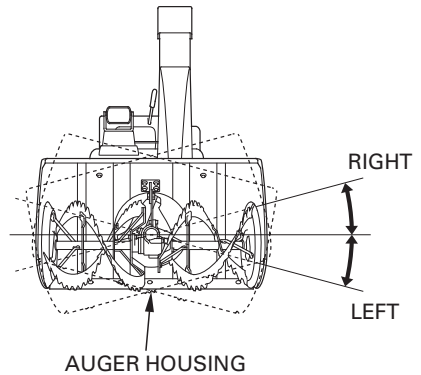

AUGER HOUSING

Reset Switch

Use the reset switch to return the auger housing to the reset height position (current set position). This switch is convenient to move the auger housing by operating the auger housing control switch and to return the auger housing to the original height position. The reset height position has been set at the factory in the position where the snow clearing part contacts the ground with the snowblower set on a level ground.

The reset height position can be changed (see page 63 for reset height position changing procedure).

The reset switch can not reset the right and left direction of the auger housing angle to the reset position.

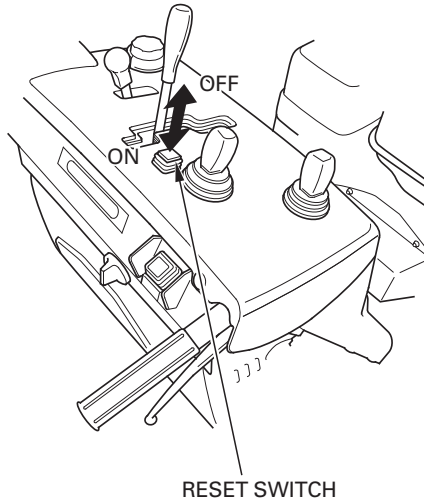

CONTROLS & FEATURES

FEATURES

Drive Control Warning Indicator (red)

The drive control warning indicator (red) turns on for a few seconds when the engine switch is turned from OFF to ON. The indicator goes off while the engine is running. If the indicator does not come on when starting and it comes on or blinks while the engine is running, contact your authorized Honda snowblower dealer.

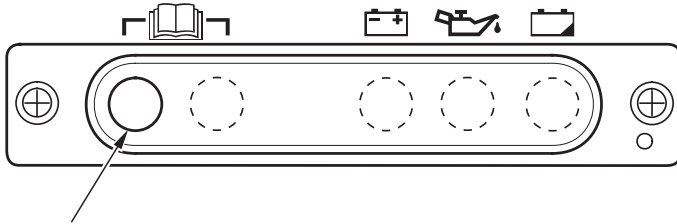

DRIVE CONTROL WARNING INDICATOR (red)

Drive Control Warning Indicator (orange)

The drive control warning indicator (orange) turns on when the engine switch is turned from OFF to ON. The indicator (orange) turns off when the engine is started. The indicator goes off while the engine is running. If the indicator does not come on when starting and it comes on or blinks while the engine is running, contact your authorized Honda snowblower dealer.

If the orange indicator blinks, the drive control protection system may be activated because of such things as a drive control system problem or overload. See page 60 for the protection system.

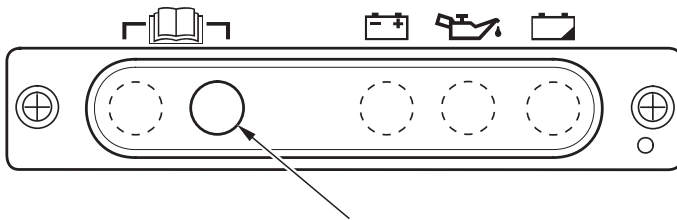

DRIVE CONTROL WARNING INDICATOR (orange)

Charging Indicator

The charging indicator (red) turns on when the engine switch is turned from OFF to ON. The indicator turns off when the engine is started. If the indicator does not come on when starting or comes on while the engine is running, contact your authorized Honda snowblower dealer.

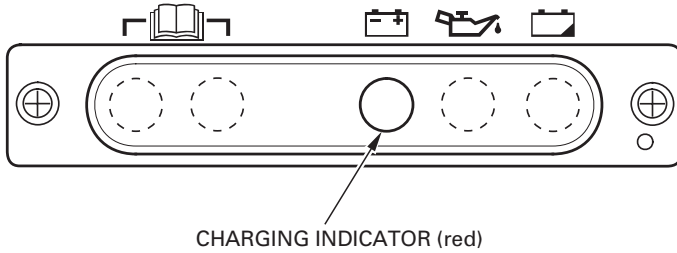

Oil Indicator

The oil indicator (red) comes on when the engine oil level is low. Turn the engine switch to the ON position. If it is normal, the oil indicator (red) comes on for a few seconds and then it goes off. The engine does not start unless the oil indicator (red) goes off. Check the engine oil level (see page 79).

If the oil indicator (red) comes on while the snowblower is running, move the snowblower immediately to a safe, level place, stop the engine, and check the engine oil level (see page 79).

NOTICE

Do not keep operating the snowblower with the oil indicator (red) on. It will cause the engine to malfunction.

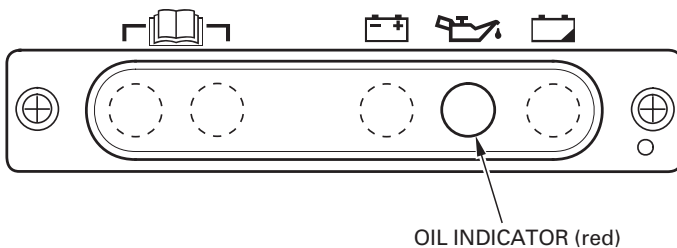

CONTROLS & FEATURES

Battery Indicator

The battery indicator will blink when the voltage is getting low (see pages 91 and 94 for battery charge or replacement).

The battery indicator (orange) turns on for a few seconds when the engine switch is turned from OFF to ON and then go off. The indicator should be off when the engine is running. If the indicator does not come on when starting, or it comes on while the engine is running, contact your authorized Honda snowblower dealer.

Even if the engine is not running, the indicator will blink when the engine switch is in the ON position (The engine switch should be turned OFF immediately).

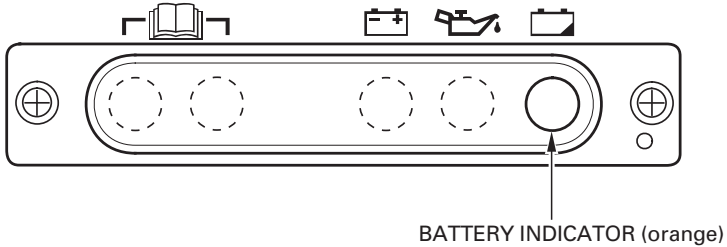

Fuel Gauge

The fuel gauge indicates the amount of fuel in the tank. When the fuel gauge needle enters the EMPTY range, refill the tank as soon as possible.

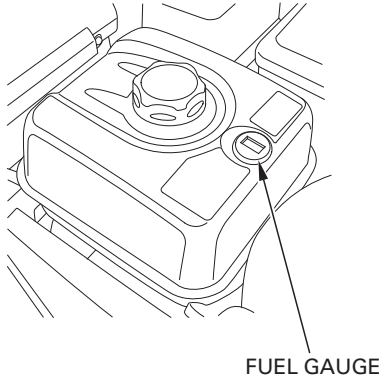

Headlight

The headlight turns on when the engine switch is in the ON position. The battery may become discharged when the light is ON while the engine is OFF.

If the headlight does not come on, the battery might be faulty or the bulb might be blown. Check the battery.

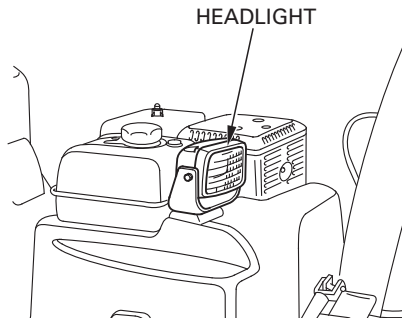

CONTROLS & FEATURES

Wheel Pin

⚠ WARNING

Do not remove the wheel pins with the snowblower on a slope. The snowblower might move unintentionally, causing serious injury.

Before removing the wheel pins, place the snowblower on a level surface. Stop the rotating parts, stop the engine, and remove the engine switch key.

Remove the cotter pins and wheel pins from the rear right and left wheels. This allows the track to rotate freely so the operator can move the snowblower if the motor malfunctions. Use a new cotter pin when replacing the wheel pin.

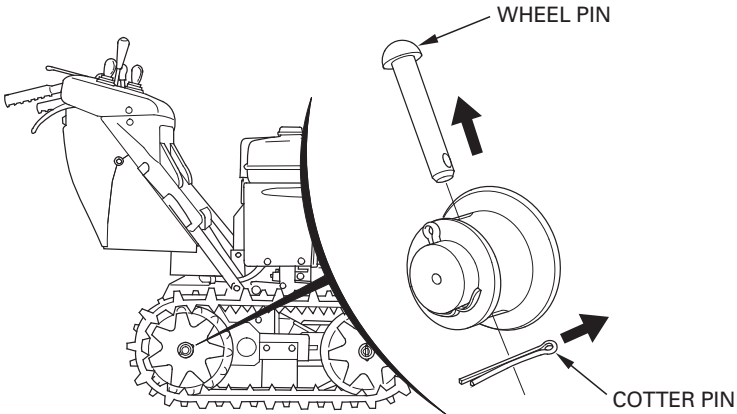

Snow Clearing Bar

If the snow discharge chute or snow blowing mechanism becomes clogged, stop the engine and use this bar to unclog it.

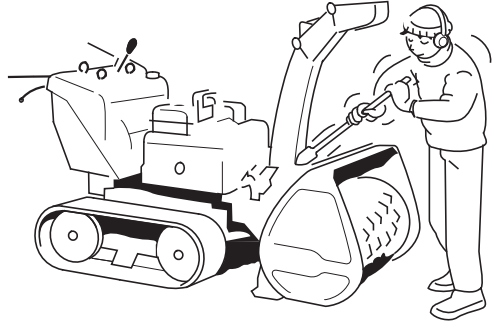
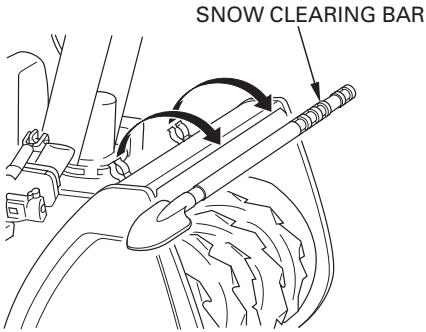

▲ WARNING

Before removing clogged snow, be sure to stop the engine, and make sure that all rotating parts have come to a complete stop. Remove the key from the engine switch.

Failure to do so can cause serious injury or death.

CONTROLS & FEATURES

Skid, Scraper

Adjust the skid and the scraper according to the road surface condition where you are to clear the snow. Use the skid to determine the height from the ground to the auger, and adjust the scraper to make the snow surface even (see page 42).

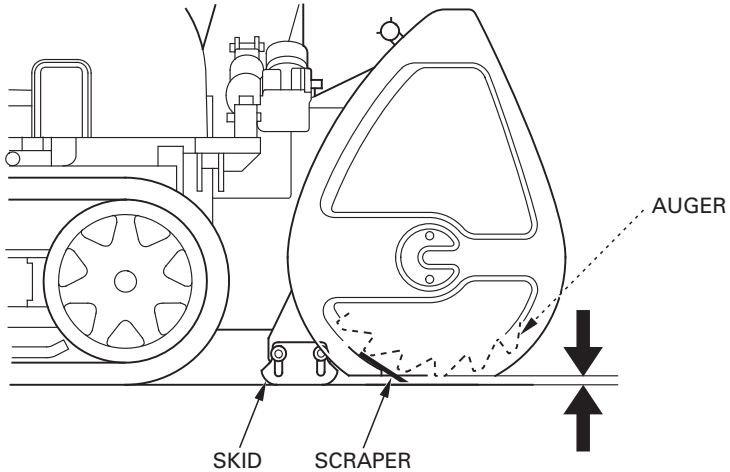

BEFORE OPERATION

ARE YOU READY TO GET STARTED?

Your safety is your responsibility. A little time spent in preparation will significantly reduce your risk of injury.

Knowledge

Read and understand this manual. Know what the controls do and how to operate them.

Familiarize yourself with the snowblower and its operation before you begin using it. Know how to quickly shut off the snowblower in case of an emergency.

IS YOUR SNOWBLOWER READY TO GO?

For your safety, and to maximize the service life of your equipment, it is very important to take a few moments before you operate the snowblower to check its condition. Be sure to take care of any problem you find, or have your servicing dealer correct it, before you operate the snowblower.

WARNING

Improperly maintaining this snowblower, or failing to correct a problem before operation, could cause a malfunction in which you could be seriously injured.

Always perform a pre-operation inspection before each operation, and correct any problem.

Before beginning your pre-operation checks, be sure the snowblower is on a level surface and the engine switch is in the OFF position.

BEFORE OPERATION

Check the General Condition of the Snowblower:

- Look around and underneath the snowblower for signs of oil or gasoline leaks.
- Check the auger housing and the discharge chute for accumulation of packed snow or ice. Clean the auger housing and discharge chute before starting the snowblower.
- Look for signs of damage.
- Check each control for proper operation.
- Check the battery electrolyte level (see page 89).
- Check the auger and blower for loose or broken bolts. If broken, replace them with new ones (see page 85).
- Check the skid and scraper (see page 42).
- Check that all nuts, bolts, and screws are tightened.
- Check that the indicators work properly.
- Check the entire machine for any other faults that might have been caused previously.

Check the Engine

- Check the oil level (see page 79).
- Check the fuel level (see page 77). Starting with a full tank will help to eliminate or reduce operating interruptions for refueling.

CHECK YOUR WORK AREA

For your safety and the safety of others, always inspect the area before operating the snowblower.

Objects

Anything which can be picked up by the augers and thrown is a potential hazard to you and others. Thoroughly inspect the area where the equipment is to be used and remove all doormats, sleds, boards, wires, stones, and nails, from the work area.

People and Pets

People and animals near the work area can move into your snowblowers path or into a position where they could be struck by thrown objects. Clear the area of people, especially children, and pets. Their safety is your responsibility.

Work Area

Check the condition of the snow. Adjust your snowblower ground speed (not engine speed) and snowblowing swath accordingly.

Check the skid for proper adjustment. Adjust the skid to obtain the auger ground clearance for the type of surface the snowblower will be operated over (see page 42).

Carefully check the area before backing the snowblower.

OPERATION

SNOWBLOWING PRECAUTIONS

Before operating the snowblower for the first time, please review both the *SNOWBLOWER SAFETY* chapter (see page 6) and the *BEFORE OPERATION* chapter (see page 35).

Even if you have operated other snowblowers, take time to become familiar with how this snowblower works, and practice in a safe area until you build up your skills.

Never tamper with or alter any of the controls or safety devices on the snowblower.

For your safety, do not start or operate the engine in an enclosed area such as a garage. Your snowblower's exhaust contains poisonous carbon monoxide gas that can collect rapidly in an enclosed area and cause illness or death.

WARNING

Exhaust contains poisonous carbon monoxide gas that can build up to dangerous levels in closed areas. Breathing carbon monoxide can cause unconsciousness or death.

Never run the engine in a closed, or even partly closed area where people may be present.

STARTING THE ENGINE

1. Turn the fuel valve lever to the ON position. Be sure that the drain knob is tightened securely.

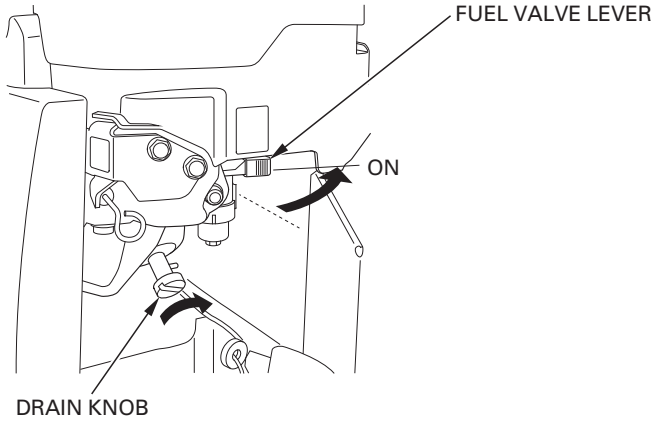

2. Set the main shift lever in the N (neutral) position.

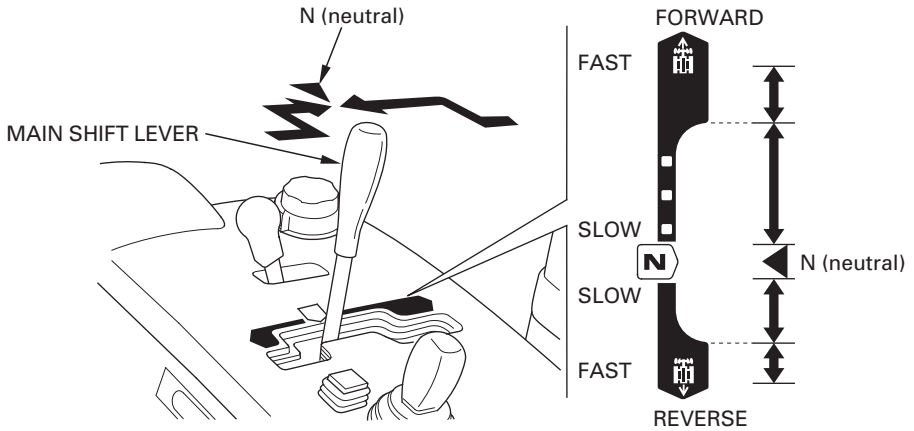

OPERATION

3. Turn the engine switch to the START position and release the switch key after the engine starts. The switch automatically returns to the ON position.

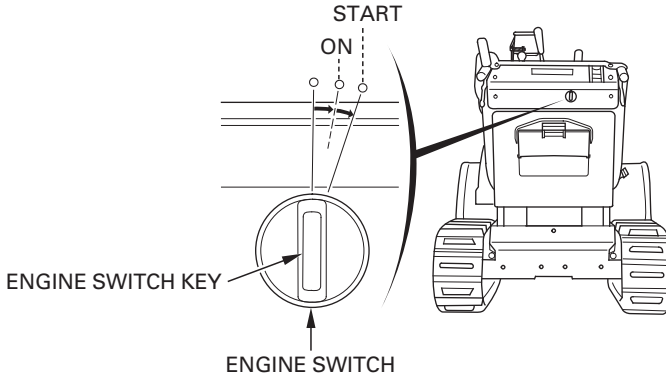

NOTICE

- *If the engine does not start within 5 seconds after cranking the starter, wait for about 10 seconds and restart the engine.*
- *Note that the starter does not crank when the auger clutch switch or drive clutch lever is operated (engine start interlock).*
- This snowblower is equipped with the auto choke system. However, it may not function properly when foreign material (ice, etc.) is stuck on the system.
- If the engine does not start after 5 attempts, push and release the manual start lever one time and try to start the engine.
- If the engine still does not start, push and hold the manual start lever and try again.

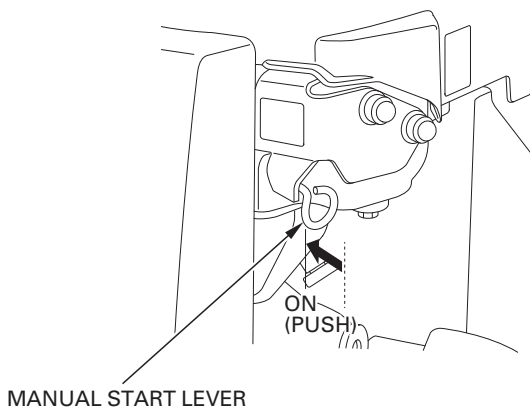

4. After starting the engine, check that the engine speed is stabilizing. Move the throttle control lever to the SLOW position gradually and warm up the engine to the normal operating temperature.

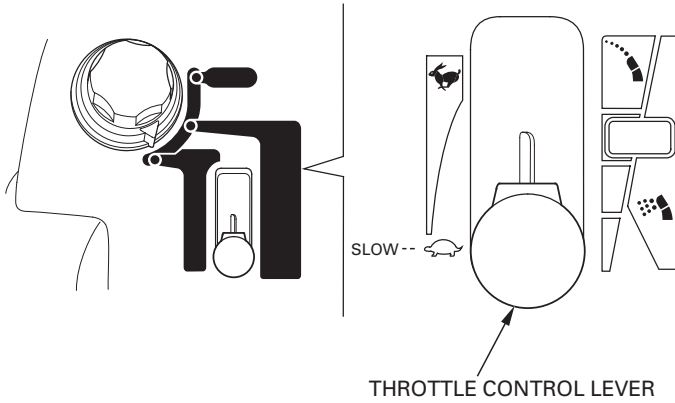

OPERATION

OPERATING THE CONTROLS FOR CLEARING SNOW

NOTICE

Before operating this equipment you should read and understand the SNOWBLOWER SAFETY on page 6 through 10.

Efficiency of the snow removal work is significantly affected by the snow condition (e.g. dry, wet etc.). Adjust the skid position, the scraper position, and the auger housing height as needed for optimum snow removal.

Skid and Scraper

Adjust the skid for the auger housing ground clearance best suited to your snow removal conditions.

1. Hold the auger housing horizontally and lower the auger on the ground by operating the auger control switch.
2. Turn the engine switch OFF and remove the key from the engine switch.
3. Loosen the bolts and adjust the skid and scraper height in accordance with the road surface condition where you are to clear the snow (see pages 43 and 44).

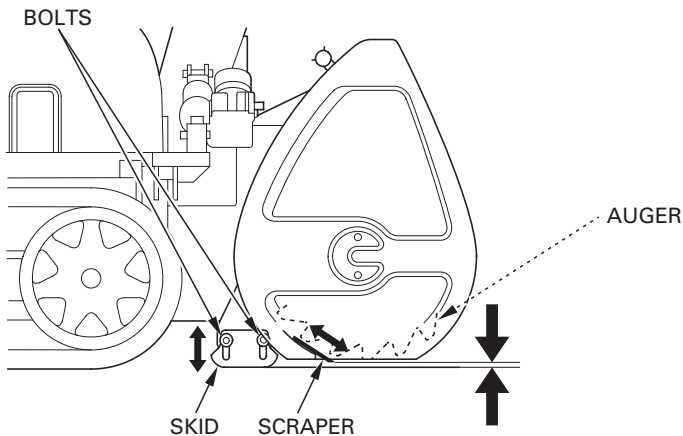

Adjust the skid equally on both sides.

Be sure to tighten the skid and scraper bolts securely after making adjustment.

NOTICE

Do not use the snowblower on rough or uneven surfaces with the auger ground clearance set for hard snow or surfaces.

This may cause serious damage to the snow blowing mechanism.

● **Adjust the skid and scraper in the following cases**

- When the auger interferes with the road surface while it is turning:
- When clearing the snow from the graveled road:
Raise the auger approximately 0.5 in (12 mm) from the ground and secure the skid in this position.
Secure the scraper by raising it 0.3 in (7 mm) from the ground.
Do not clear the snow thoroughly from the ground. Leave some on the ground to prevent gravel and other foreign material being caught in the auger.

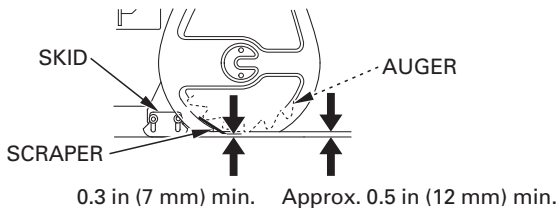

- To break down the hardened snow that dropped from the roof:
- When the snow is too hard to dig in, making the snowblower rise on the snow:
Raise the skid and scraper to the uppermost position of the adjustment range with the auger in contact with the ground, and secure the skid and scraper in position.

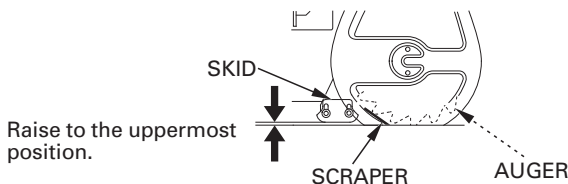

NOTICE

Note that the road surface can be damaged and stones can be thrown out of the auger if it comes in contact with the ground. Return the skid and scraper to the original position when operating the snowblower under normal conditions.

OPERATION

- To clear the snow more neatly:
Bring the skid to be in contact with the ground with the auger raised approximately 0.4 in (10 mm) from the ground. Secure the skid in this position.
Secure the scraper by bringing it in contact with the ground.

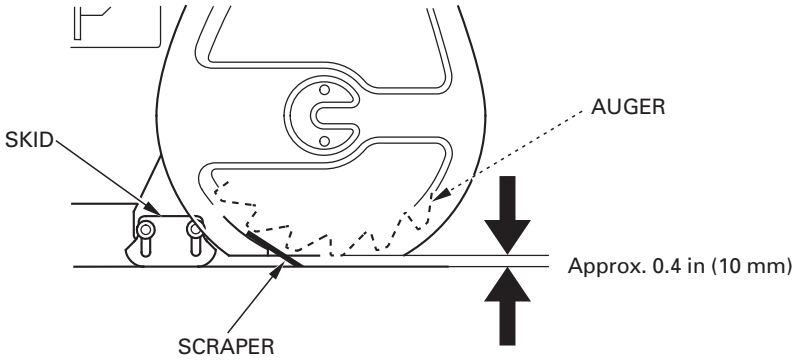

Factory pre-set clearance:

At the scraper (A): 0.1–0.3 in (3–7 mm)

At the auger (B): 0.3–0.5 in (8–12 mm)

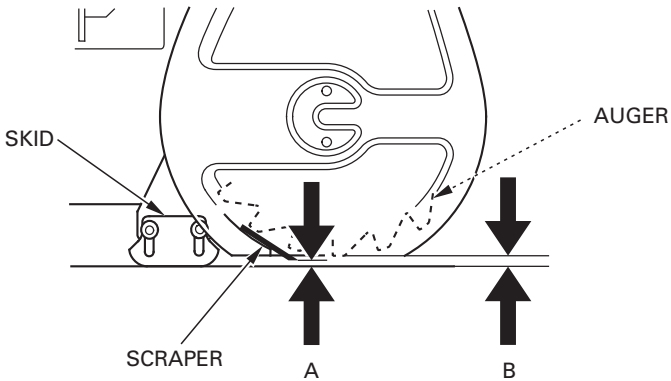

Auger Housing Height

1. Operate the auger housing control switch back and forth. The auger housing height can be adjusted without discrete steps.
To raise: Pull the auger housing control switch to UP.
To lower: Push the auger housing control switch to DOWN.
2. Release the auger housing control switch, and the auger housing is secured in the position.

HIGH: Use this position when clearing the snow in steps and use it when reversing or driving the snowblower. (When the mode selector switch is AUTO or POWER, use this position when reversing the snowblower.)

MIDDLE: Position for normal clearing. (Use this position to clear the snow normally.)

LOW: Position for clearing hardened snow. (Use this position when the snow you are to clear is hardened and the snow clearing part of the snowblower tends to get raised.)

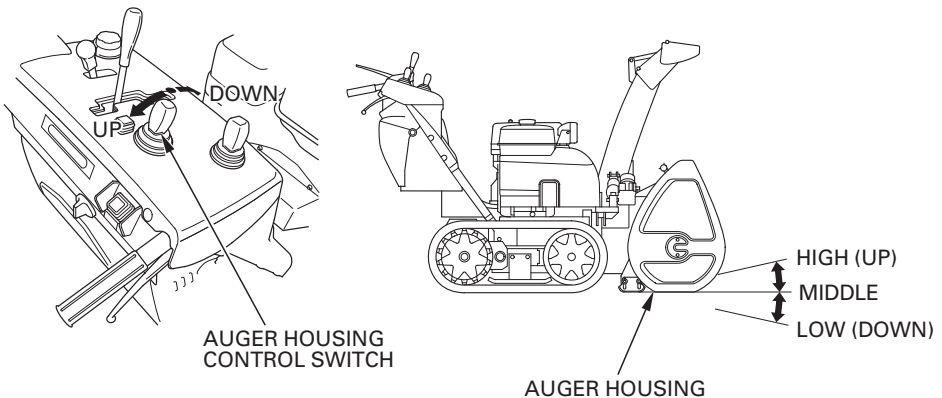

OPERATION

NOTICE

Use the LOW position (i.e. position for clearing hardened snow) only for clearing hardened snow. Do not set the auger housing in this position while clearing soft snow or clearing on a bumpy road. This can damage the road surface or cause stones to be thrown out of the auger, which is very dangerous. Also, it can cause excessive wear and damage to the snow clearing part of the snowblower.

- When the mode selector switch is in AUTO or POWER, the auger housing automatically rises while going in reverse.
In case the auger clutch switch is in the ON position, the auger is automatically returned to the original position when the snowblower is transporting forward again.
- If you want to stop the automatic movement of the auger housing, change the mode selector switch to the "MANUAL" position.
- To stop the automatically movement of the auger housing, push the control switch once to the opposite direction of the movement.
- Frequent operation of the auger housing control switch activates the protection function and makes the drive control warning indicator (orange) blink, which prevents you from adjusting the snow clearing part of the snowblower. Stop operating the auger housing control switch and wait a few seconds before operating the switch again.

Auger Housing Tilt Angle

When the auger housing is tilted during snow removal, adjust the tilt angle by operating the auger housing control switch.

When the auger is tilted toward the right: Move the switch toward the right.

When the auger is tilted toward the left: Move the switch toward the left.

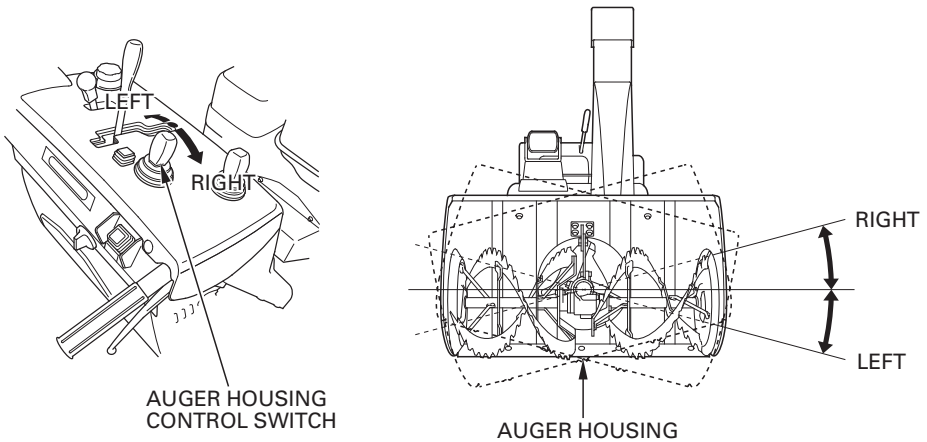

NOTICE

- *The control motor may overheat, which can cause a malfunction of the protector circuit and motor and make the auger housing unadjustable.*
- *Stop operating the switch when the auger housing reaches the right end or left end position. Do not hold the auger housing control switch operated.*

OPERATION

Operation

1. Start the engine (see pages 39 through 41).
2. Select the snow clearing work mode.
 - 1. Check that the main shift lever is in the N (neutral) position.
 - 2. Select the appropriate work mode to clear the snow by turning the mode selector switch to either the MANUAL, POWER, or AUTO position.

Note that the operation and performance of the snowblower differ according to the work mode you select. Select the appropriate work mode for your situation (see pages 17 and 18 for the characteristics of each mode).

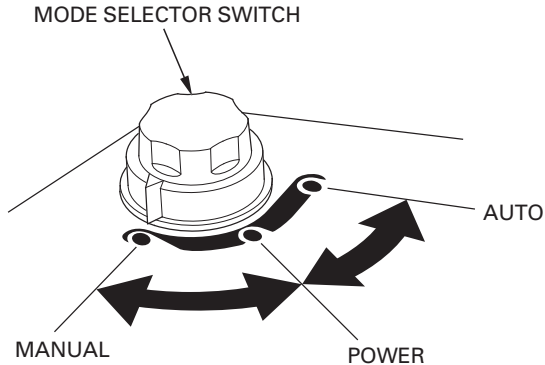

Tips for selecting the work mode:

AUTO mode: see page 49.

- 1) Not familiar with operating the snowblower.
- 2) Does not want to operate the various switches while clearing the snow.
- 3) Want to clear the snow as quietly as possible.
- 4) Want the auger to rise up as little as possible.

POWER mode: see page 52.

- 1) Want to adjust the traveling speed automatically according to the workload while clearing the snow.
- 2) Want to throw the snow far from the snowblower.
- 3) Want to finish clearing the snow as quickly as possible.

MANUAL mode: see page 55.

Want to operate the switches as you like.

NOTICE

Do not turn the mode selector switch to another position while the snowblower is moving. The electronic control unit will interpret this as a failure; the snowblower will stop moving and the auger will stop turning.

When the snowblower and auger stop moving/turning, move the main shift lever to the N (neutral) position, release the drive clutch lever once, and then squeeze it again.

Check each part to verify it is in its proper position before resuming operation.

3a. Clearing in AUTO mode

Setting the mode selector switch at the AUTO position can simplify clearing the snow. AUTO mode keeps the auger from rising, adjusts the engine speed automatically, etc.

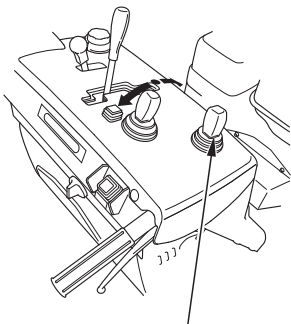

CHUTE CONTROL SWITCH

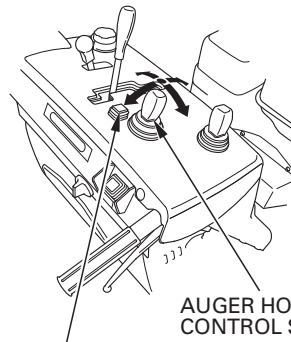

RESET SWITCH

AUGER HOUSING CONTROL SWITCH

1) Operate the chute control switch to adjust the snow discharge direction and angle (see page 25).

2) Operate the auger housing control switch to adjust the auger to be parallel to the road surface (see pages 45 and 47).

- You can return the auger to the initial height position by pushing the reset switch.
- If you return the auger to the initial height position by pushing the reset switch, the auger can hit against the road surface or can be raised from the road, resulting in some snow left on the ground, depending on the road condition and the position of the snowblower. Adjust the auger height position as needed.

OPERATION

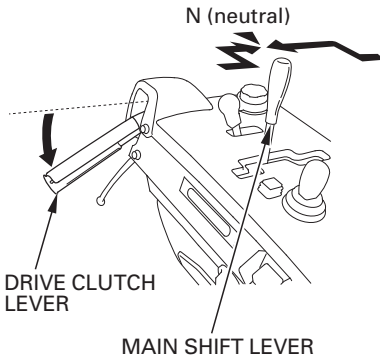

3) Check that the main shift lever is in the N (neutral) position and squeeze the drive clutch lever.

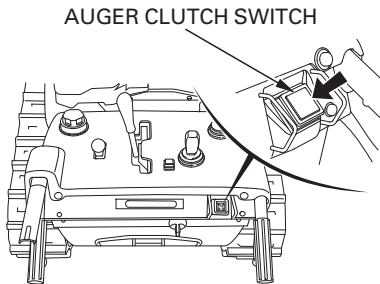

4) Push the auger clutch switch to operate on the auger and blower.

- The indicator (green) comes on when you push the auger clutch switch.
- When the auger clutch switch is pushed for four seconds or longer, the protection function gets armed. This stops the auger and blower from turning.
- The auger and blower keep turning while the drive clutch lever is squeezed. Push the auger clutch switch again to stop the auger and blower. (Interlocking operation of the drive clutch lever and auger clutch switch)

⚠ WARNING

The auger and blower will start to turn when the drive clutch lever and auger clutch switch is operated. Check around the snowblower for safety before operating the lever and switch.

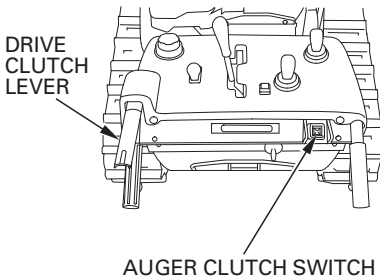
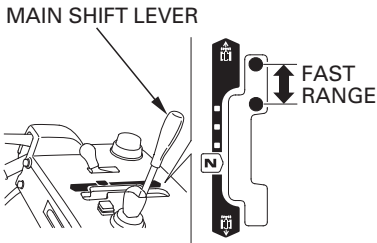
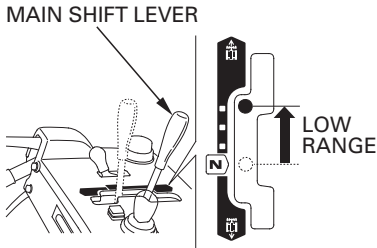

5) Move the main shift lever fully to the end of the forward low speed range slowly and clear the snow.

- When the auger hits against the road or inclines to a side, adjust the auger housing position by operating the auger housing control switch.
- When the snow is small in volume or light in nature, move the main shift lever to the high speed side. Perform minor adjustment of the main shift lever to stabilize the operating speed if necessary.

6) When the drive clutch lever is released, the auger clutch switch indicator (green) goes off, both the auger and blower stop turning, and the snowblower stops moving.

Turn the auger clutch switch OFF if you move the snowblower without performing the snowblowing operation.

OPERATION

3b. Clearing in POWER mode

With the mode selector switch in the POWER position you can adjust the engine speed and snow discharge distance. Use the throttle control lever to adjust the engine speed, which determines how fast snow is picked up and how far it is thrown. Use the chute control switch to adjust height and direction of the snow discharge.

- Note that the throttle control lever only functions after the auger is turning. The engine speed is maintained automatically in POWER mode.

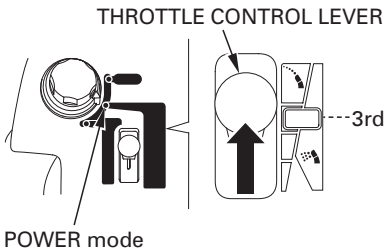

- 1) Set the throttle control lever in the third position from the bottom.

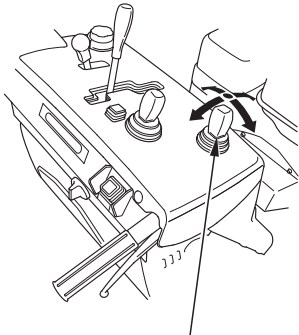

- 2) Operate the chute control switch to adjust the snow discharge direction and angle (see page 25).

CHUTE CONTROL SWITCH

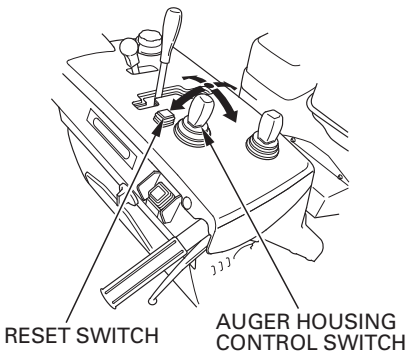

- 3) Operate the auger housing control switch to adjust the auger to be parallel to the road surface (see pages 45 and 47).

- You can return the auger to the initial height position by pushing the reset switch.
- If you return the auger to the initial height position by pushing the reset switch, the auger can hit against the road surface or can be raised from the road, resulting in some snow left on the ground, depending on the road condition and the position of the snowblower. Adjust the auger height position as needed.

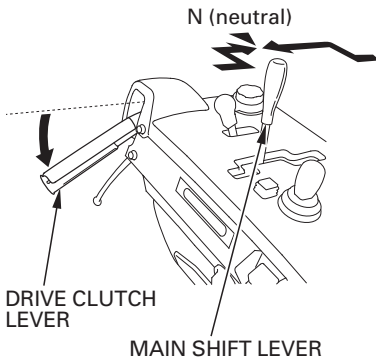

4) Check that the main shift lever is in the N (neutral) position and squeeze the drive clutch lever.

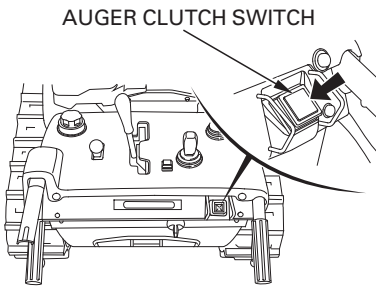

5) Push the auger clutch switch to operate on the auger and blower.

- The indicator (green) comes on when you push the auger clutch switch.
- When the auger clutch switch is pushed for four seconds or longer, the protection function gets armed. This stops the auger and blower from turning.
- The auger and blower keep turning while the drive clutch lever is squeezed. Push the auger clutch switch again to stop the auger and blower. (Interlocking operation of the drive clutch lever and auger clutch switch)

⚠ WARNING

The auger and blower will start to turn when the drive clutch lever and auger clutch switch is operated. Check around the snowblower for safety before operating the lever and switch.

OPERATION

MAIN SHIFT LEVER

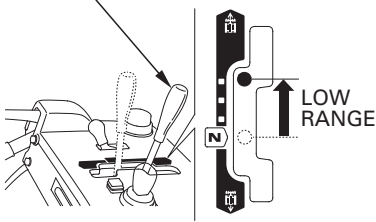

MAIN SHIFT LEVER

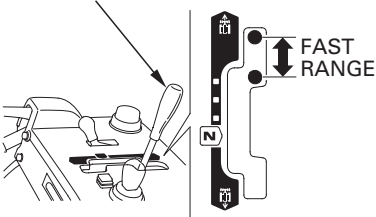

THROTTLE CONTROL LEVER

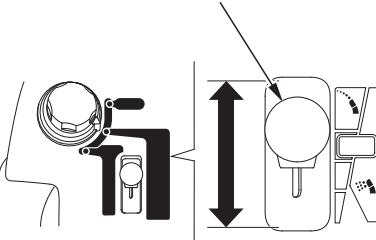

DRIVE CLUTCH LEVER

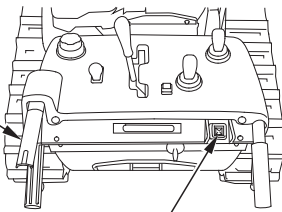

AUGER CLUTCH SWITCH

6) Move the main shift lever fully to the end of the forward low speed range slowly and clear the snow.

- When the auger hits against the road or inclines to a side, adjust the auger housing position by operating the auger housing control switch.
- When the snow is small in volume or light in nature, move the main shift lever to the high speed side. Perform minor adjustment of the main shift lever to stabilize the operating speed if necessary.

7) After stabilizing the operating speed, adjust the snow discharge distance by operating the throttle control lever as needed.

- Traveling speed will decrease by increasing the snow discharge distance, while the speed will increase by decreasing the snow discharge distance. Adjust the snow discharge distance by operating the throttle control lever as needed.

8) When the drive clutch lever is released, the auger clutch switch indicator (green) goes off, both the auger and blower stop turning, and the snowblower stops moving.

Turn the auger clutch switch OFF if you move the snowblower without performing the snowblowing operation.

3c. Clearing in MANUAL mode

Nothing is controlled automatically when the mode selector switch is set at the MANUAL position. Engine speed and operating speed can be adjusted freely by selecting the MANUAL mode.

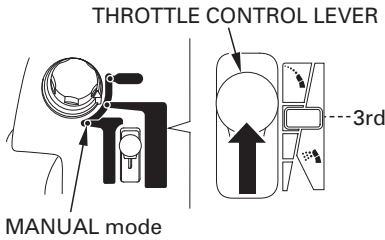

1) Set the throttle control lever in the third position from the bottom.

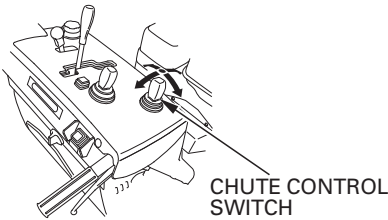

2) Operate the chute control switch to adjust the snow discharge direction and angle (see page 25).

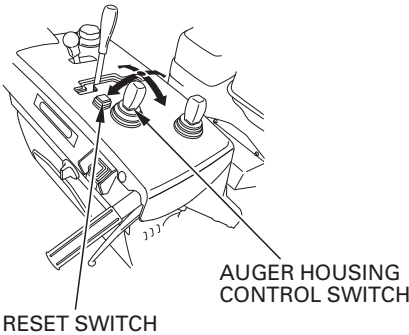

3) Operate the auger housing control switch to adjust the auger to be parallel to the road surface (see pages 45 and 47).

- You can return the auger to the initial height position by pushing the reset switch.
- If you return the auger to the initial height position by pushing the reset switch, the auger can hit against the road surface or can be raised from the road, resulting in some snow left on the ground, depending on the road condition and the position of the snowblower. Adjust the auger height position as needed.

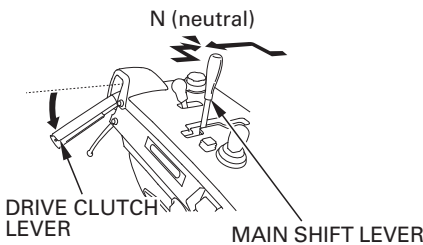

4) Check that the main shift lever is in the N (neutral) position and squeeze the drive clutch lever.

OPERATION

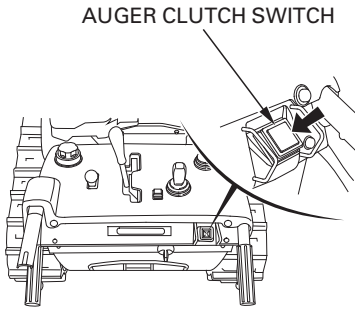

- 5) Push the auger clutch switch to operate on the auger and blower.
- The indicator (green) comes on when you push the auger clutch switch.
 - When the auger clutch switch is pushed for four seconds or longer, the protection function gets armed. This stops the auger and blower from turning.
 - The auger and blower keep turning while the drive clutch lever is squeezed. Push the auger clutch switch again to stop the auger and blower. (Interlocking operation of the drive clutch lever and auger clutch switch)

⚠ WARNING

The auger and blower will start to turn when the drive clutch lever and auger clutch switch is operated. Check around the snowblower for safety before operating the lever and switch.

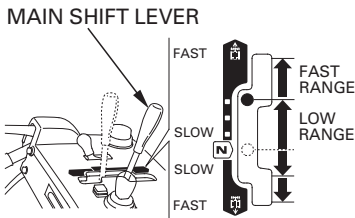

- 6) Adjust the operating speed by moving the main shift lever to a position within the slow speed range according to the volume and nature of the snow, and clear the snow.
- Even when you are clearing the snow, adjust the operating speed as needed by operating the main shift lever according to the change of the volume and nature of the snow.
 - When the snow is small in volume or light in nature, move the main shift lever to the high speed side. Perform minor adjustment of the main shift lever to stabilize the operating speed if necessary.

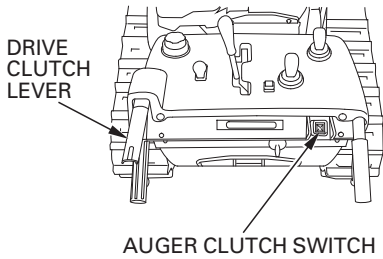

7) When the drive clutch lever is released, the auger clutch switch indicator (green) goes off, both the auger and blower stop turning, and the snowblower stops moving.

Turn the auger clutch switch OFF if you move the snowblower without performing the snowblowing operation.

OPERATION

Turning the Snowblower

You can change the direction of your snowblower while moving by squeezing either the right or left steering lever. You can make two types of turns, normal turn and turn on the spot (to correct the driving direction on the spot), depending on the position of the main shift lever and the degree of squeezing pressure on the steering lever.

To turn to the left: Squeeze the steering lever (left).

To turn to the right: Squeeze the steering lever (right).

● Normal turn

To make a large turn: Squeeze a steering lever lightly.

To make a small turn: Squeeze a steering lever fully.

● Turn on the spot

Squeeze the steering lever fully on the side to which you want to turn the snowblower while driving forward at low speed, and you can make a turn on the spot (i.e. correct the direction on the spot). This function facilitates changing or correcting the direction in a narrow place such as when moving the snowblower in or out of the storage.

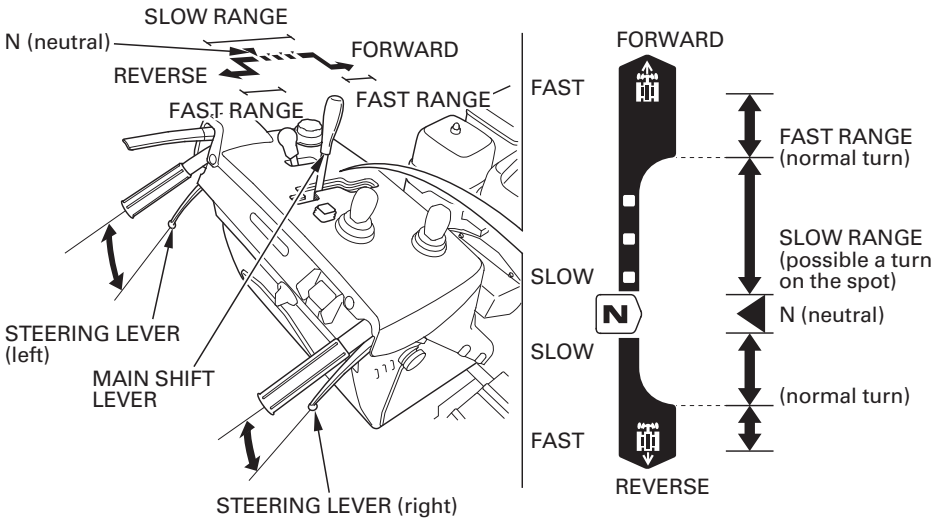

Example: To turn to the left (To turn to the right is the mirror image of the illustrations.)

● **Normal turn (Left steering lever squeezed halfway)**

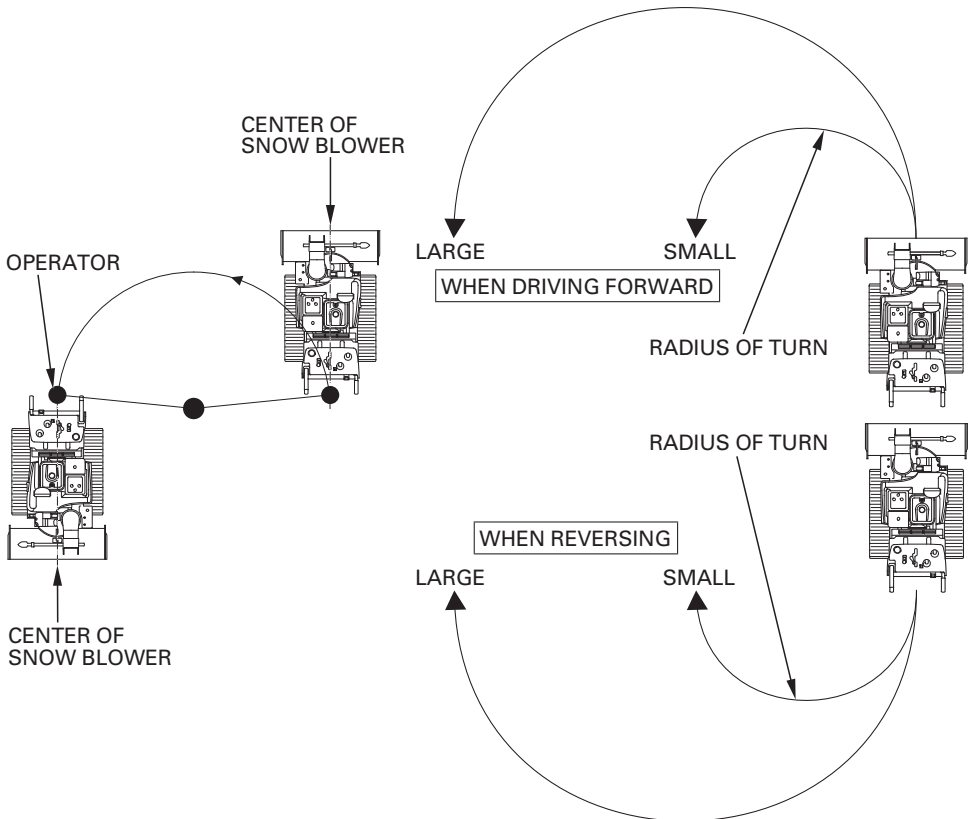
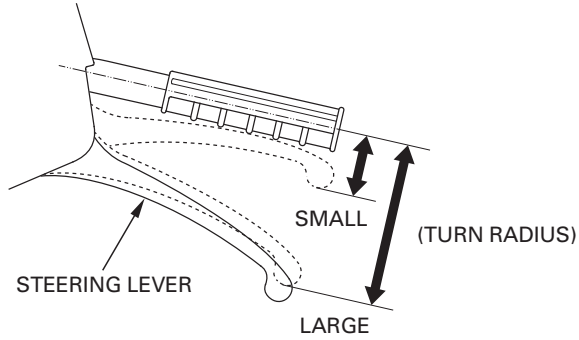

OPERATION

● Turn on the spot (Steering lever fully squeezed)

The track on the side to which you are to turn turns in the reverse direction, which makes the snowblower turn on the spot (corrects the direction on the spot).

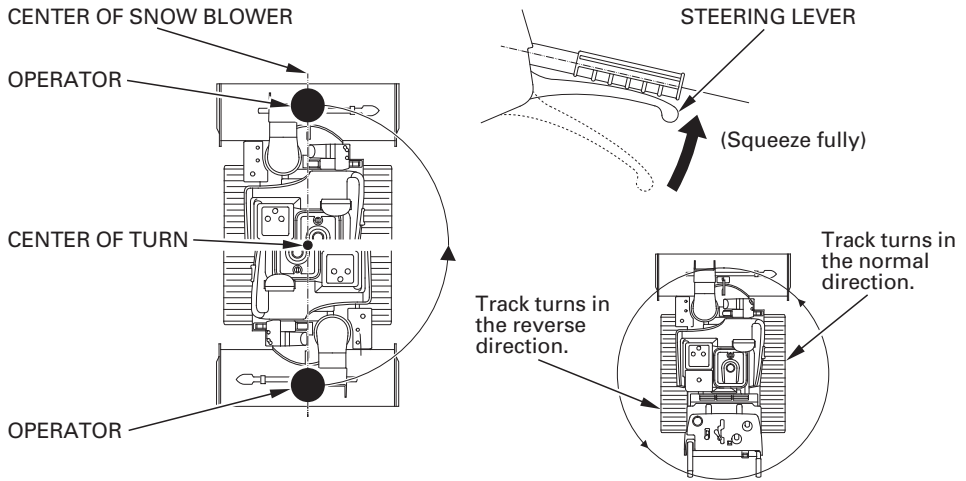

Drive motor control protection system

This snowblower is designed to drive with the motor power. When an excessive load is applied to the motor, which depends on an operation condition of the snowblower, the protection circuit is armed making the drive control warning indicator (orange) come on and blink and possibly slowing down or stopping the snowblower.

If this symptom occurs, turn the engine switch to the OFF position and wait until the motor cools down before restarting the engine. If the drive control warning indicator (orange) does not come on and blink this time, it indicates that the snowblower has been restored to its normal condition and you can continue clearing the snow.

Note that the protection system functions frequently if the motor is under an excessive load. Adjust the load to a proper level.

The snowblower might be faulty if the engine does not restart or the drive control warning indicator (orange) blinks when restarting the engine. Move the snowblower to a safe place by removing the wheel pins from the tracks and check for the trouble by referring to the symptom-to-troubleshooting table (see pages 112 and 113). Have your authorized Honda snowblower dealer check and repair your snowblower if necessary.

See page 124 for wheel pin removal.

Battery Run System

Use the battery run system to drive the snowblower in case the engine does not start.

- 1. Set the main shift lever in the N (neutral) position.
- 2. Release the drive clutch lever to set it in the STOP position.
- 3. Turn the engine switch to the ON position.
- 4. Squeeze the right and left steering levers simultaneously for approximately 3 seconds.

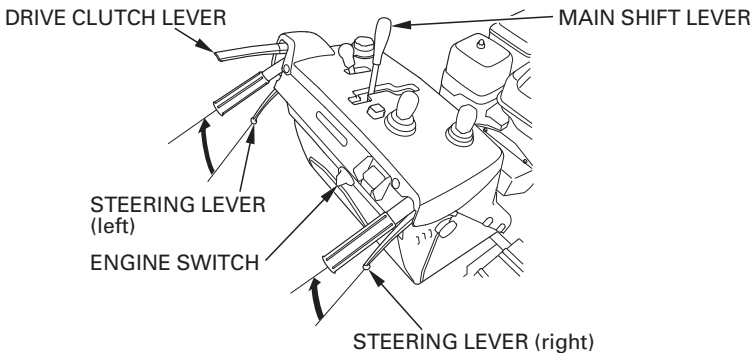

- 5. Both the drive control warning indicator (red) and the drive control warning indicator (orange) blink after squeezing the right and left steering levers for approximately 3 seconds. Squeeze the drive clutch lever when the indicators blink.

If the drive clutch lever and the main shift lever are not operated within 5 seconds after the drive control warning indicators start to blink, the indicators stop blinking but they stay on automatically. The battery run system is automatically disarmed this time, which prevents the snowblower from running with the battery power. Return the engine switch to the OFF position and restart the engine. The battery run mode keeps on while the drive clutch lever is squeezed.

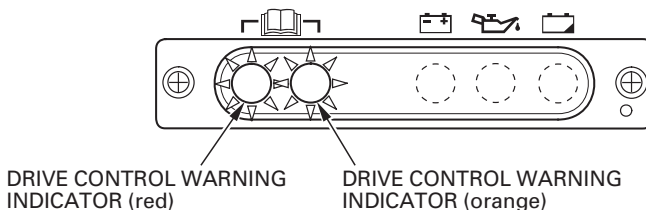

OPERATION

- 6. Run the snowblower at an adequate speed by operating the main shift lever.
- 7. After running, turn the engine switch to the OFF position.
- Use the battery run system to drive the snowblower in case the engine does not start.
- The battery run system consumes battery power. Take care not to operate the battery run system for longer than 3 aggregate minutes and operate it with the battery fully charged. Operating the battery run system for longer than 3 minutes or frequent operation will discharge the batteries, which prevents you from starting the engine and snowblower.
- Be sure to turn the engine switch to the OFF position after starting with the battery run system. Leaving the engine switch at the ON position will discharge the battery and may cause an accident.
- Recharge the battery as needed (see page 94).
- The battery run system allows you to drive the snowblower when the engine is not running.
Be sure to set the main shift lever in the N (neutral) position before starting the battery run system.
- The snowblower may not start under the following conditions. If it does not start, move the snowblower to a safe place by removing the wheel pins (see page 124).
 - Battery is discharged.
 - Drive motor is faulty.
 - Wheel pin(s) is/are broken or missing.
 - Motor drive controller is faulty.

Auger Housing Reset Height Position

This snowblower allows you to change the auger housing reset height position (the position where the auger housing returns when you push the reset switch) as needed.

Change the reset height position (auger housing return position set at present) in case of the following.

1. When you do not want to lower the auger housing to be level to the ground, as the gravel can be caught in the auger during clearing on a graveled ground.
2. When the scraper/skid position was changed, making the reset height position no longer adequate for clearing the snow.
3. When each part of the snowblower is worn, making the reset height position no longer adequate for clearing the snow.
4. When you want to change the reset height position to a position you want.

Park the snowblower on firm, level ground to change the reset height position.

- 1. Turn the engine switch to the ON position (see page 40).
- 2. Push the reset switch and hold it pushed for five seconds or longer.
 - The auger housing moves to the reset height position by pushing the reset switch. Keep pushing the reset switch.
- 3. Release the reset switch and check whether the reset switch indicator is blinking.

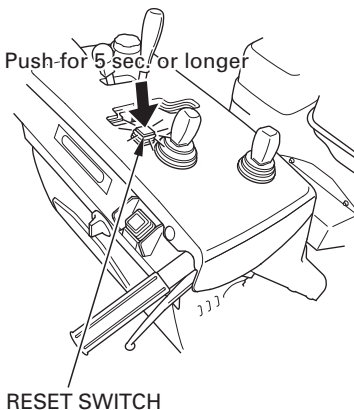

OPERATION

- 4. Operate the auger housing control switch to set the auger housing in a height position you want.

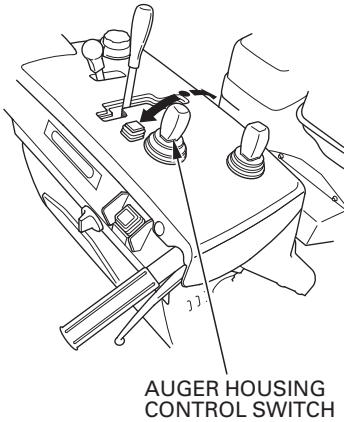

- 5. Push the auger clutch switch. The reset switch indicator goes off and the reset height position is changed.

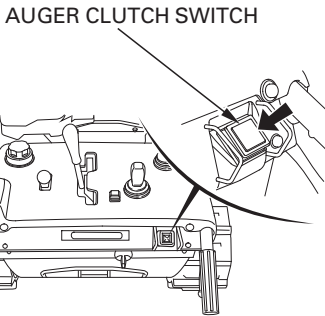

- 6. Turn the engine switch to the OFF position.

- Note that you cannot operate the snowblower without turning the engine switch to the OFF position once.

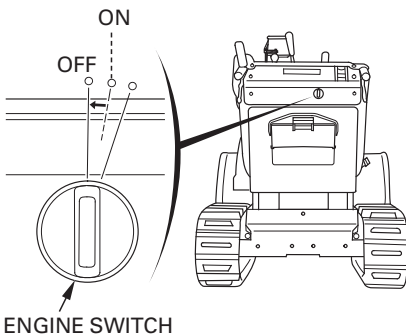

If you cannot change the reset height position properly or if you want to return the reset height position to the factory set position, consult with your authorized Honda snowblower dealer.

CLEARING SNOW

For efficient operation, it is important to select an adequate engine speed for the required snow discharge distance and clear the snow without lowering the engine speed. If the engine speed keeps dropping by setting the main shift lever in the LOW position, clear the snow as follows.

- Clearing in narrow width
Clear the snow with the main shift lever in LOW and in narrow width by using a part of the snow blowing mechanism when the snow is deep or hard.

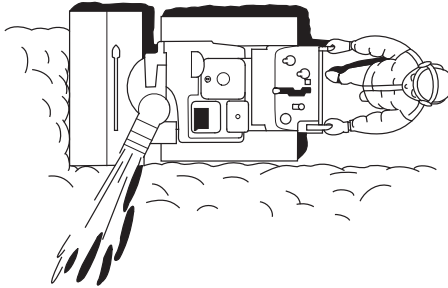

- Clearing with back and forth motions
If the snow is so hard that the snowblower tends to ride over the surface, push it back and forth to remove snow gradually.

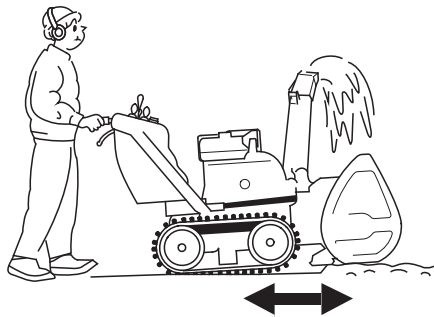

When the mode selector switch is in AUTO or POWER, the auger housing automatically rises while going in reverse. In case the auger clutch switch is in the ON position, the auger is automatically returned to the original position when the snowblower is transporting forward again.

OPERATION

● Intermittent clearing

Follow the steps below when the engine lugs against deep or heavy snow.

1. Operate the main shift lever and move it to the N (neutral) position until the snowblower recovers the engine speed. (Allow the auger clutch switch indicator (green) to come on and keep the auger turning this time.)
2. After the auger is clear of snow and the snowblower recovers the engine speed, move the main shift lever to the forward low speed range.
3. Repeat the above steps if engine speed is still reduced.



● Clearing in steps

If the height of the snow is greater than the height of the snow blowing mechanism, remove it in several steps as shown.

1. To ascend the slope:
 - Operate the auger housing control switch to raise the auger a little.
2. To dig into the snow:
 - Operate the auger housing control switch to lower the auger a little.
 - Adjust the skid position as needed (see page 43).

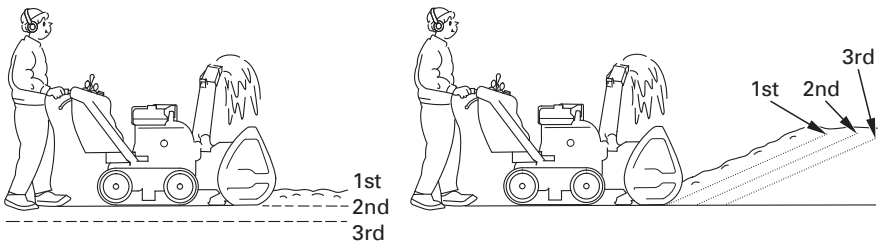

WARNING

Adjust the snow discharge chute to avoid hitting the operator, bystanders, windows, and other objects with thrown snow. Stay clear of the snow discharge chute while the engine is running.

To move from one place to another, or to change direction, use the drive clutch lever. Using the auger clutch switch will cause the snowblowing mechanism to rotate, possibly resulting in equipment damage or personal injury.

NOTICE

Be sure to set the main shift lever in SLOW RANGE when removing the snow.

OPERATION

REMOVING OBSTRUCTIONS

⚠ WARNING

If the snow discharge chute becomes clogged, stop the engine, remove the engine switch key, and use a snow clearing bar or a wooden stick to unplug the snow discharge chute.

Never put your hand into the snow discharge chute while the engine is running; serious personal injury could result.

1. If the snow discharge chute is clogged with snow during operation, remove the snow from it using the snow clearing bar.

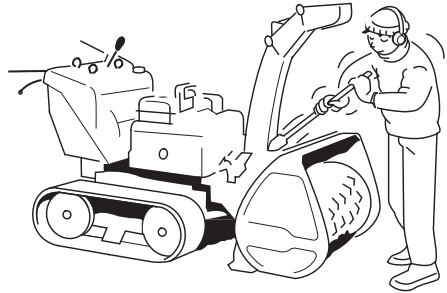
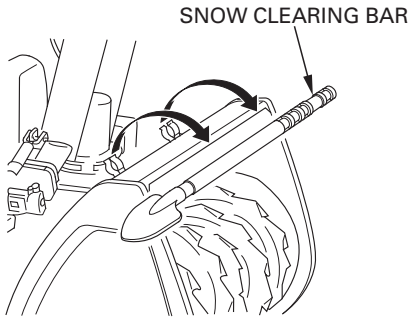

2. After clearing the snow, clean and return the snow clearing bar to its original position.

STOPPING THE ENGINE

⚠ WARNING

Park the snowblower on a firm, level ground. You could be hurt or killed if the snowblower moves unexpectedly.

Emergency engine stopping

Turn the engine switch to the OFF position and remove the key. Be sure to release the drive clutch lever and move the main shift lever to the N (neutral) position before restarting the engine.

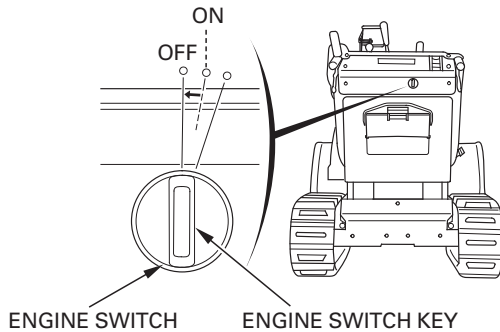

Normal engine stopping

1. Release the drive clutch lever. The snowblower stops traveling and the auger stops turning a few seconds later.

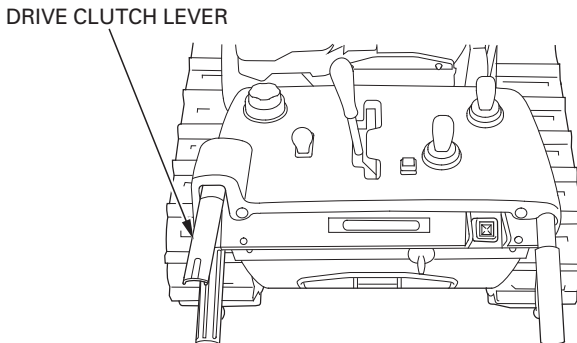

OPERATION

2. Set the main shift lever in the N (neutral) position.

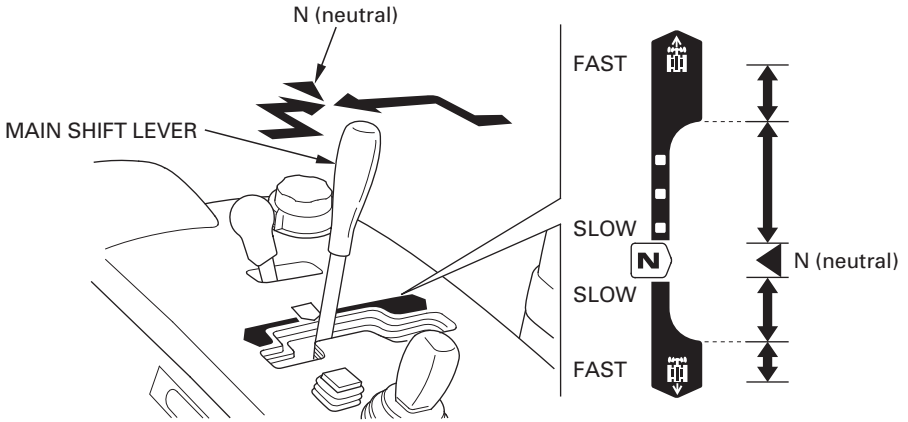

3. Move the throttle control lever to the SLOW position.

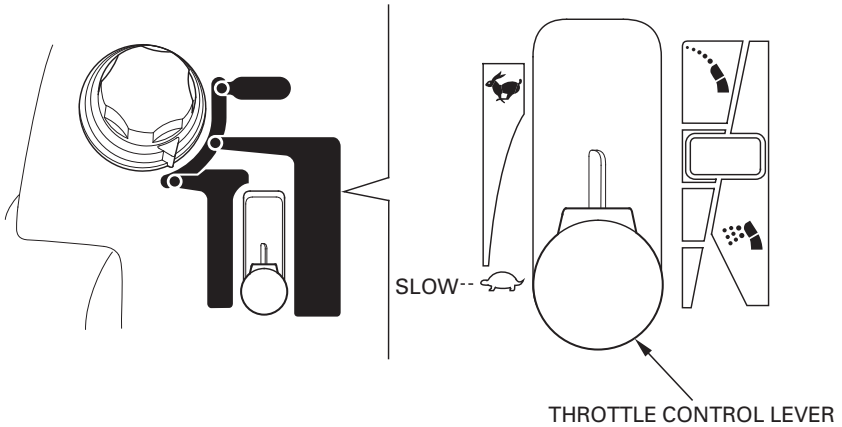

4. Operate the auger housing control switch until the snow blowing mechanism is resting on the ground firmly.

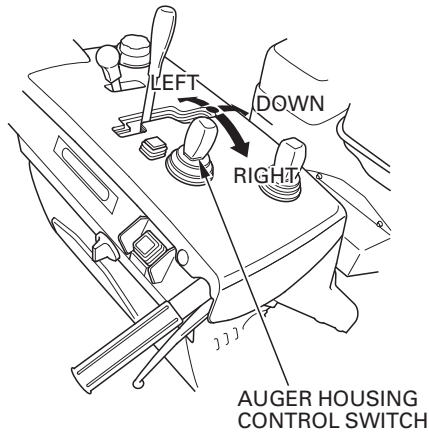

5. Turn the engine switch to the OFF position and remove the key.

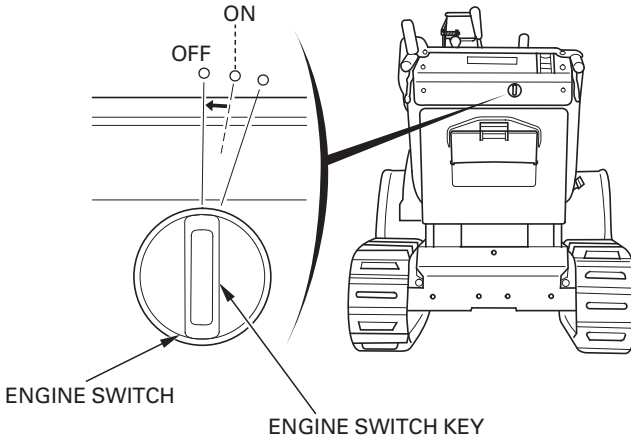

OPERATION

6. Turn the fuel valve lever to the OFF position.

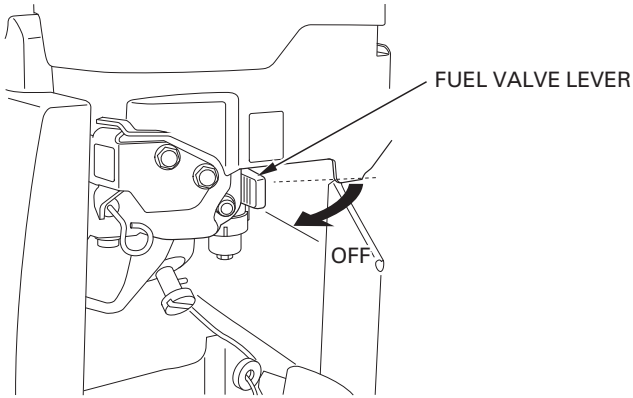

After operation, remove the snow from each part of the snowblower and store the snowblower. Snow left on the snowblower may freeze, possibly damaging the snowblower and hindering operation the next time.

SERVICING YOUR SNOWBLOWER

THE IMPORTANCE OF MAINTENANCE

Good maintenance is essential for safe, economical, and trouble-free operation. It will also help reduce air pollution.

To help you properly care for your snowblower, the following pages include a maintenance schedule, routine inspection procedures, and simple maintenance procedures using basic hand tools. Other service tasks that are more difficult, or require special tools, are best handled by professionals and are normally performed by a Honda technician or other qualified mechanic.

The maintenance schedule applies to normal operating conditions. If you operate your snowblower under unusual conditions, consult your servicing dealer for recommendations applicable to your individual needs and use. Remember that your servicing dealer knows your snowblower best and is fully equipped to maintain and repair it.

WARNING

Improper maintenance, or failure to correct a problem before operation, can cause a malfunction in which you can be seriously hurt or killed.

Always follow the inspection and maintenance recommendations and schedules in this owner's manual.

To ensure the best quality and reliability, use only new, Honda Genuine parts or their equivalents for repair or replacement.

Maintenance, replacement, or repair of the emission control devices and systems may be performed by any engine repair establishment or individual, using parts that are "certified" to EPA standards.

SERVICING YOUR SNOWBLOWER

MAINTENANCE SAFETY

Some of the most important safety precautions follow. However, we cannot warn you of every conceivable hazard that can arise in performing maintenance. Only you can decide whether or not you should perform a given task.

WARNING

Failure to properly follow maintenance instructions and precautions can cause you to be seriously hurt or killed.

Always follow the procedures and precautions in the owner's manual.

Safety Precautions

- Make sure the engine is off before you begin any maintenance or repairs. This will eliminate several potential hazards:
 - **Carbon monoxide poisoning from engine exhaust.**
Operate outside, away from open windows or doors.
 - **Burns from hot parts.**
Let the engine and exhaust system cool before touching.
 - **Injury from moving parts.**
Do not run the engine unless instructed to do so.
- Read the instructions before you begin, and make sure you have the tools and skills required.
- To reduce the possibility of fire or explosion, be careful when working around gasoline. Use only a nonflammable solvent, not gasoline, to clean parts. Keep cigarettes, sparks, and flames away from all fuel-related parts.

SERVICING YOUR SNOWBLOWER

TOOL KIT

The tools necessary for performing some of the periodic maintenance, simple adjustments and repairs are supplied in the tool kit.

Spare shear bolts and nuts are also located in the tool kit.

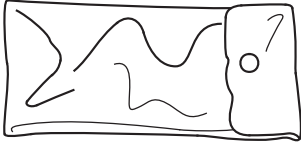

TOOL BAG



10 x 12mm BOX-END WRENCH

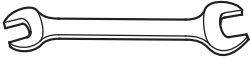

10 x 14mm WRENCH

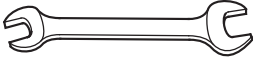

12 x 17mm WRENCH (2)

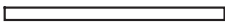

PLUG WRENCH HANDLE

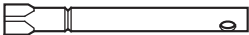

SPARK PLUG WRENCH

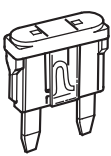

5 A

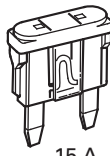

15 A

SPARE FUSE



SPARE FUSE COVER



PLIERS

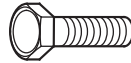

BLOWER SHEAR BOLT (5)

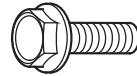

AUGER SHEAR BOLT (10)



8 mm SELF LOCK NUT (15)



COTTER PIN (2)

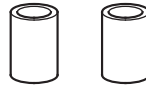

TUBE (2)
(for battery terminal covers)

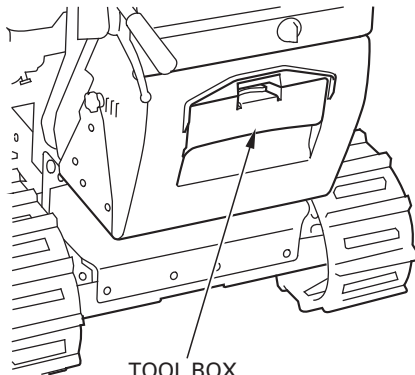

TOOL BOX

SERVICING YOUR SNOWBLOWER

MAINTENANCE SCHEDULE

REGULAR SERVICE PERIOD (3) Performed at every indicated month or operating hour interval, whichever comes first.		Each use	Every Year		First month or 20 hrs.	Every 100 hrs.	Every 300 hrs.	Every 4 years
			Before operation	Before storage				
Item								
Engine oil	Check level	o						
	Change		o(1)		o	o(1)		
Motor reduction gear oil	Check		o(2)					
Auger transmission oil	Change	Every 2 years (2)						
Battery electrolyte (If applicable)	Check level	o						
	Check level and gravity		o(1)(2)					
Spark plug	Check-adjust		o(1)					
	Replace						o	o
Auger skid shoes and scraper	Check-adjust	o	o(1)					
Track	Check-adjust		o(1)		o			
Auger and blower shear bolt	Check	o						
Bolts, Nuts, Fasteners	Check	o						
Fuel sediment cup	Check			o				
Fuel tank and carburetor	Drain			o				
Anti corrosion oil	Apply oil			o				
Chute cable	Check-adjust		o(1)(2)		o(1)(2)			
Auger belt	Check-adjust		o(1)(2)(4)		o(1)(2)(4)			
ACG belt	Check-adjust		o(1)(2)(4)		o(1)(2)(4)			
Idle speed	Check-adjust		o(2)				o(2)	
Valve Clearance	Check-adjust		o(2)				o(2)	
Combustion chamber	Clean	After every 1,000 hrs. (2)						
Fuel tank and filter	Clean					o(2)		o(2)
Fuel tube	Check	Every 2 years (2)						
	Replace							o(2)

- (1) These parts may required more frequent inspection and replacement under heavy use.
- (2) These items should be serviced by your servicing dealer.
- (3) For professional commercial use, log hours of operation to determine proper maintenance intervals.
- (4) Check the belt for wear or damage. Replace the belt with a new one if it is worn or damaged.

Failure to follow this maintenance schedule could result in non-warrantable failures.

SERVICING YOUR SNOWBLOWER

REFUELING

With the engine stopped, check the fuel gauge. Refill the tank if the fuel level is low. Do not fill above the maximum fuel level.

⚠ WARNING

Gasoline is highly flammable and explosive.

You can be burned or seriously injured when handling fuel.

- Stop the engine and keep heat, sparks, and flames away.
- Handle fuel only outdoors.
- Wipe up spills immediately.

Refuel in a well-ventilated area before starting the engine. If the engine has been running, allow it to cool. Refuel carefully to avoid spilling fuel. Do not fill above the maximum fuel level. After refueling, tighten the fuel tank cap securely.

Never refuel the snowblower inside a building where gasoline fumes may reach flames or sparks. Keep gasoline away from appliance pilot lights, barbecues, electric appliances, power tools, etc.

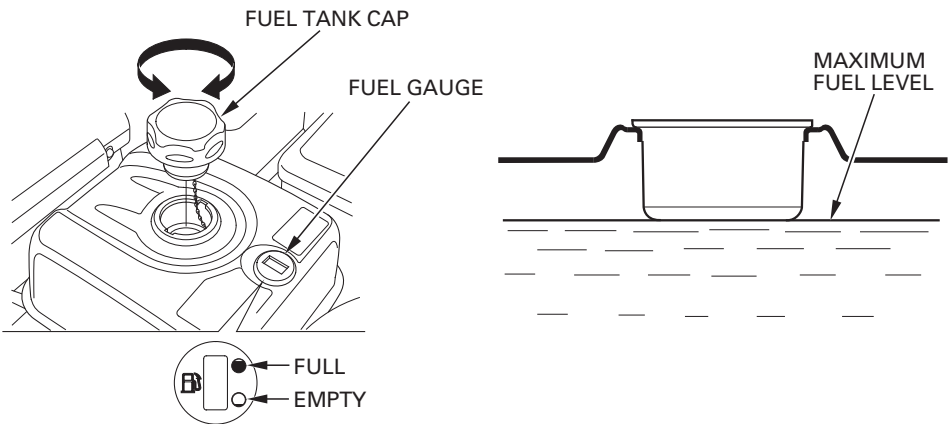

SERVICING YOUR SNOWBLOWER

Refill the fuel tank from the right side (fuel tank side) of the snowblower.

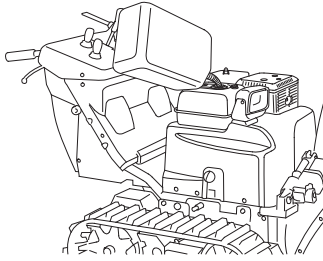

Spilled fuel is not only a fire hazard, it causes environmental damage. Wipe up spills immediately.

NOTICE

Fuel can damage paint and plastic. Be careful not to spill fuel when filling your fuel tank. Damage caused by spilled fuel is not covered under warranty.

FUEL RECOMMENDATIONS

This engine is certified to operate on unleaded gasoline with a pump octane rating of 86 or higher.

You may use regular unleaded gasoline containing no more than 10% ethanol (E10) or 5% methanol by volume. In addition, methanol must contain cosolvents and corrosion inhibitors.

Use of fuels with content of ethanol or methanol greater than shown above may cause starting and/or performance problems. It may also damage metal, rubber, and plastic parts of the fuel system.

Engine damage or performance problems that result from using a fuel with percentages of ethanol or methanol greater than shown above are not covered under warranty.

Never use stale or contaminated gasoline or an oil/gasoline mixture. Avoid getting dirt or water in the fuel tank.

If your equipment will be used on an infrequent basis, please refer to the fuel section of the STORAGE chapter (see page 100) for additional information regarding fuel deterioration.

SERVICING YOUR SNOWBLOWER

ENGINE OIL LEVEL CHECK

Check the engine oil level with the engine stopped and in a level position.

1. Remove the oil filler cap/dipstick and wipe it clean.
2. Insert and remove the dipstick without screwing it into the filler hole. Check the oil level shown on the dipstick.
3. If the oil level is low, fill with the recommended oil (see page 81) to the upper limit on the oil filler cap/dipstick.
4. Reinstall the oil filler cap/dipstick.

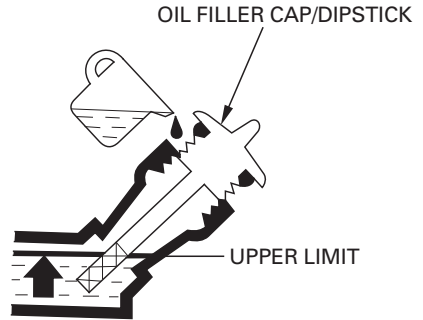
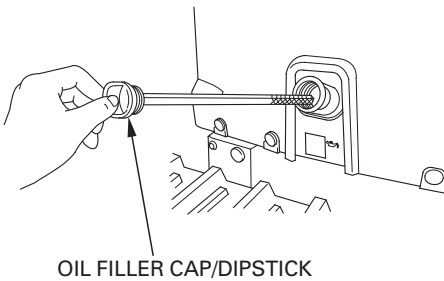

NOTICE

Running the engine with a low oil level can cause engine damage. This type of damage is not covered by the Distributor's Limited Warranty.

SERVICING YOUR SNOWBLOWER

ENGINE OIL CHANGE

Drain the oil while the engine is still warm to assure rapid and complete draining.

1. Place a suitable container below the engine to catch the used oil, and then remove the oil filler cap/dipstick, 10 × 15 mm drain plug, and sealing washer.

To avoid loosening the 10 × 15 mm drain plug extension, hold it with a 17 mm wrench while loosening the drain plug with a 10 mm box-end wrench.

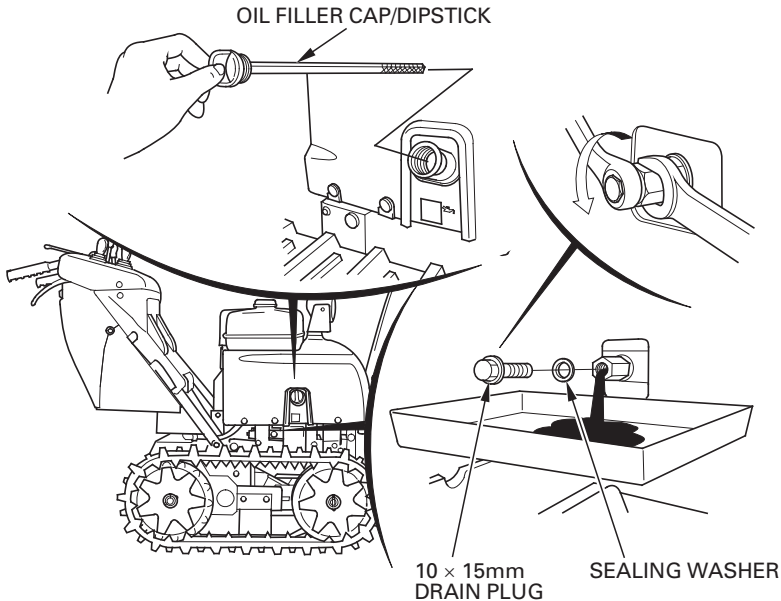

2. Allow the used oil to drain completely into an approved container, and then reinstall the 10 × 15 mm drain plug with a new sealing washer, and tighten it securely.

NOTICE

Improper disposal of engine oil can be harmful to the environment. If you change your own oil, please dispose of used motor oil properly. Put it in a sealed container, and take it to a recycling center. Do not throw it in the trash, pour it on the ground, or pour it down a drain.

SERVICING YOUR SNOWBLOWER

3. Fill with new recommended oil up to the upper limit.

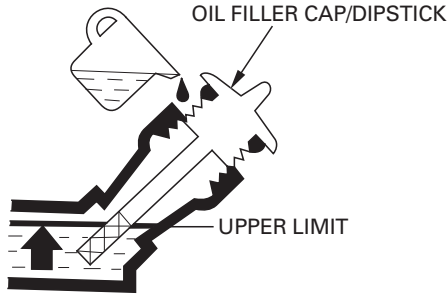

NOTICE

Running the engine with a low oil level can cause engine damage. This type of damage is not covered by the Distributor's Limited Warranty.

4. Screw in the oil filler cap/dipstick securely.

Wash your hands with soap and water after handling used oil.

ENGINE OIL RECOMMENDATIONS

Oil is a major factor affecting performance and service life. Use a 4-stroke automotive detergent oil.

SAE 5W-30 is recommended for general use.

The SAE oil viscosity and service classification are on the API label on the oil container. Honda recommends that you use API SERVICE category SJ or later (or equivalent) oil.

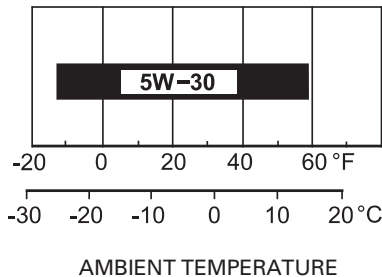

SERVICING YOUR SNOWBLOWER

SPARK PLUG SERVICE

Recommended spark plug: BPR5ES (NGK)
W16EPR-U (DENSO)

NOTICE

Use only the recommended spark plugs or equivalent. Spark plugs which have an improper heat range may cause engine damage.

To ensure proper engine operation, the spark plug must be properly gapped and free of deposits. If the engine has been running, the muffler will be very hot. Be careful not to touch the muffler.

1. Remove the spark plug cap.
2. Clean any dirt from around the spark plug base.
3. Use the spark plug wrench supplied in the tool kit to remove the spark plug.

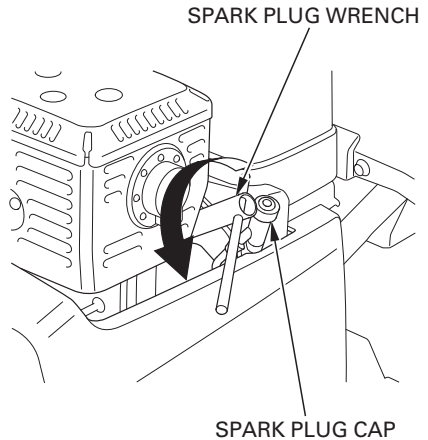

SERVICING YOUR SNOWBLOWER

4. Inspect the spark plug. Replace it if the electrodes are worn or if the insulator is cracked, chipped, or fouled.

5. Measure the plug gap with a wiretype feeler gauge. Correct as necessary by carefully bending the side electrode.

The gap should be:
0.028–0.031 in (0.7–0.8 mm)

6. Make sure that the spark plug sealing washer is in good condition, and thread the spark plug in by hand to prevent cross-threading.

7. After the spark plug is seated, tighten with a spark plug wrench to compress the washer.

If installing a new spark plug, tighten 1/2 turn after the spark plug seats to compress the washer. If reinstalling a used spark plug, tighten 1/8 to 1/4 turn after the spark plug seats.

NOTICE

The spark plug must be securely tightened. An improperly tightened spark plug can become very hot and may damage the engine.

8. Attach the spark plug cap.

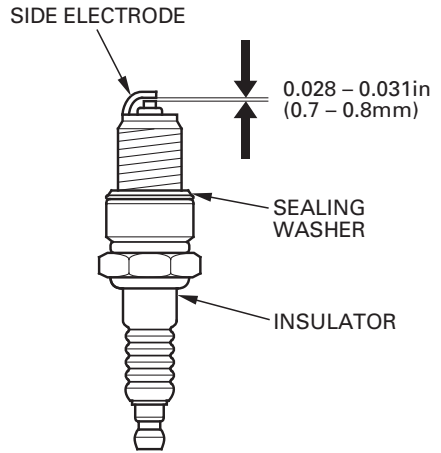

SERVICING YOUR SNOWBLOWER

TRACK ADJUSTMENT

Make sure the tracks are clean and dry before adjustment. The tracks cannot be correctly adjusted if clogged with snow or debris, or coated with ice. Check the track deflection by pressing down midway between the wheels. When correctly adjusted, the track will deflect 0.63–0.79 in (16–20 mm) when pressed with a force of 22 lbf (10 kgf).

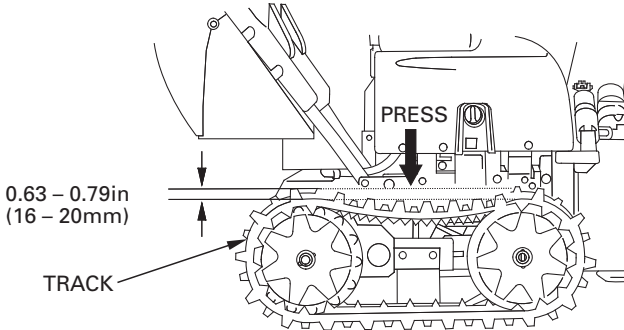

Adjusting Procedure

1. Loosen the lock nuts of the left and right tension bolt, and turn the adjusting nuts to correctly tension both tracks.
2. After adjustment, tighten the lock nuts securely.

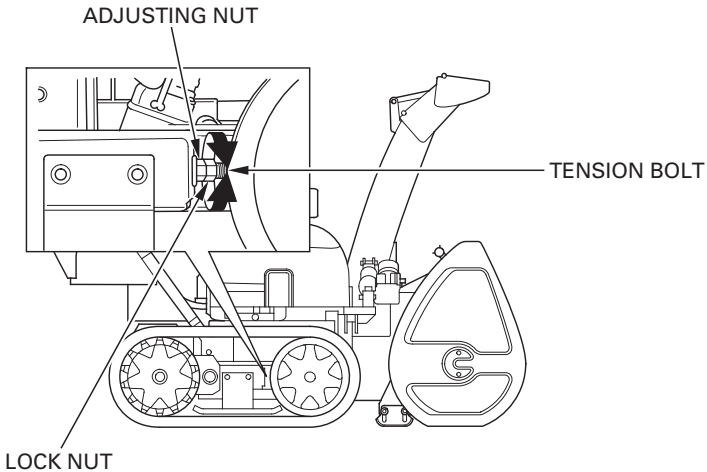

SERVICING YOUR SNOWBLOWER

AUGER AND BLOWER INSPECTION

Check the auger, auger housing, blower, and shear bolts for signs of damage or other faults. If any of the shear bolts are broken, replace them with the ones furnished with the snowblower. Additional shear bolts and nuts are available from authorized Honda snowblower dealers.

NOTICE

Shear bolts are designed to break under force that would otherwise damage auger and blower parts. Do not replace shear bolts with ordinary hardware bolts.

SERVICING YOUR SNOWBLOWER

SHEAR BOLT REPLACEMENT PROCEDURE

1. Place the snowblower on a firm, level surface.
2. Make sure the auger clutch switch is in the OFF position.
3. Release the drive clutch lever.
4. Lower the auger to the lowest position with the auger housing control switch.
5. Turn the engine switch OFF, remove the engine switch key, and be sure that each rotating part comes to a complete stop.
6. Clean the auger and blower of snow, ice, or any other foreign particles.
7. Check the entire snow clearing mechanism.
8. Replace any broken shear bolts. Tighten securely.

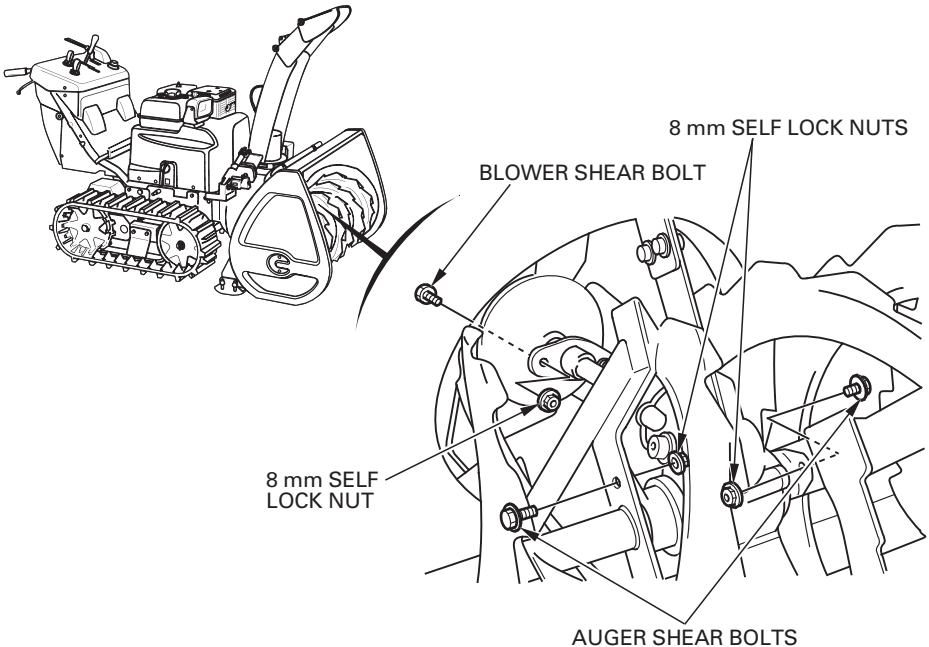

SERVICING YOUR SNOWBLOWER

AUGER/BLOWER REPLACEMENT

The auger is subject to wear as it contacts the road surface and gravel. A snowblower with a worn auger performs poorly. Replace a worn auger with a new one.

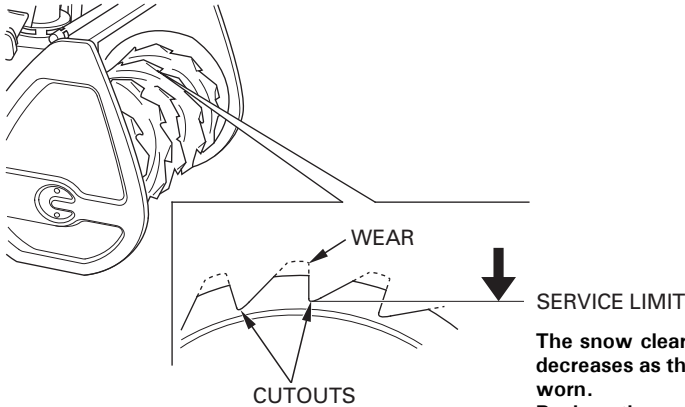

The snow clearing performance decreases as the auger becomes worn.

Replace the auger with a new one if it is worn and shows the poor performance in catching the snow.

To prevent the early failure of the auger, do not let the auger contact the road surface.

⚠ WARNING

When the auger or blower is deformed, do not try to correct it with external force. That can cause cracks and injury as a result.

- Replace the auger and blower with new ones if they contact the housing while turning, when the snow clearing performance becomes poor, or when the snow is not thrown far enough.
- Consult with your authorized Honda snowblower dealer for auger and blower replacement.

SERVICING YOUR SNOWBLOWER

BATTERY SERVICE

Your snowblower's engine charging system charges the batteries while the engine is running. However, if the snowblower is only used periodically, the batteries must be charged monthly to maintain the battery service life.

WARNING

The batteries contain sulfuric acid (electrolyte), which is highly corrosive and poisonous. Getting electrolyte in your eyes or on your skin can cause serious burns.

Wear protective clothing and eye protection when working near the batteries.

KEEP CHILDREN AWAY FROM THE BATTERY.

Emergency Procedures

Eyes — Flush with water from a cup or other container for at least fifteen minutes. (Water under pressure can damage the eye.) Immediately call 911 (USA only) or a physician.

Skin — Remove contaminated clothing. Flush the skin with large quantities of water. Call a physician immediately.

Swallowing — Drink water or milk. Call your local Poison Control Center (USA only) or a physician immediately.

SERVICING YOUR SNOWBLOWER

Battery Electrolyte Level

Remove the rear cover (see page 91) and check electrolyte level of the battery by looking at the test indicator window. The label on the battery explains the test indicator's colors.

The location of the test indicator window varies between manufacturers.

If the battery electrolyte is low level, add the distilled water to the upper level.

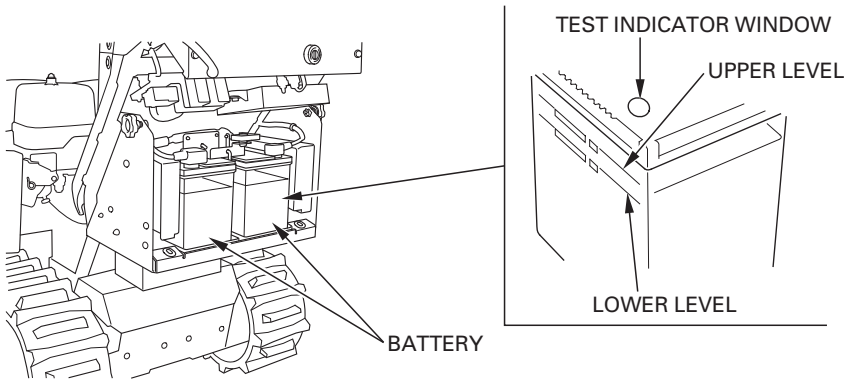

Remove the batteries (see page 91).

Remove the caps of the battery, and then fill the battery with distilled water to the upper level line. Never overfill the battery.

Any corrosion around the positive and negative terminals should be washed off with a solution of baking soda and warm water.

Dry the terminals and retighten the terminal bolts if necessary, and then coat the terminals with grease.

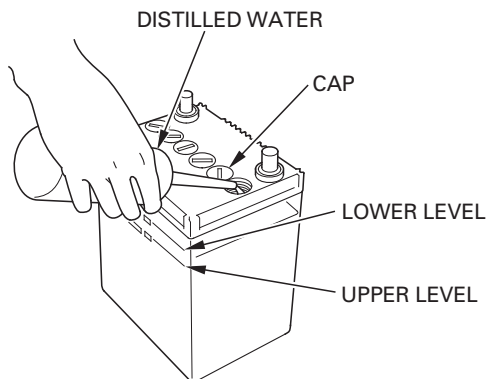

SERVICING YOUR SNOWBLOWER

After checking the electrolyte level, reinstall the rear cover (see page 93).

NOTICE

- *Use only distilled water in the battery. Tap water will shorten the service life of the battery.*
- *Do not fill the battery beyond the UPPER LEVEL. If overfilled, electrolyte may overflow and corrode snowblower components. Immediately wash off any spilled electrolyte.*

SERVICING YOUR SNOWBLOWER

Battery Removal/Installation

WARNING: Battery posts, terminals, and related accessories contain lead and lead compounds. **Wash hands after handling.**

1. Turn the engine switch to the OFF position and remove the key.
2. Pulling the rear cover back and up for remove, after loosen the 2 knobs.

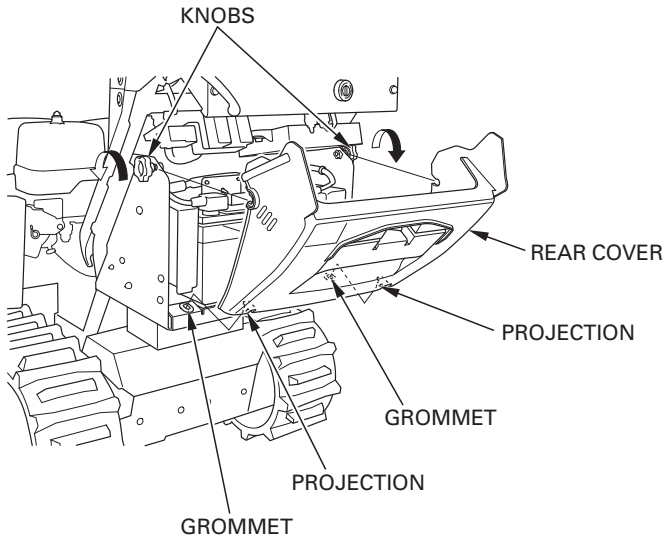

SERVICING YOUR SNOWBLOWER

3. Disconnect the negative (—) cable at the battery A negative (—) terminal and put the tube on the terminal.
4. Disconnect the positive (+) cable at the battery B positive (+) terminal and put the tube on the terminal.
5. Loosen the nuts holding the battery set plate.
6. Disconnect the battery joint cable at the battery B negative (—) terminal and at the battery A positive (+) terminal.

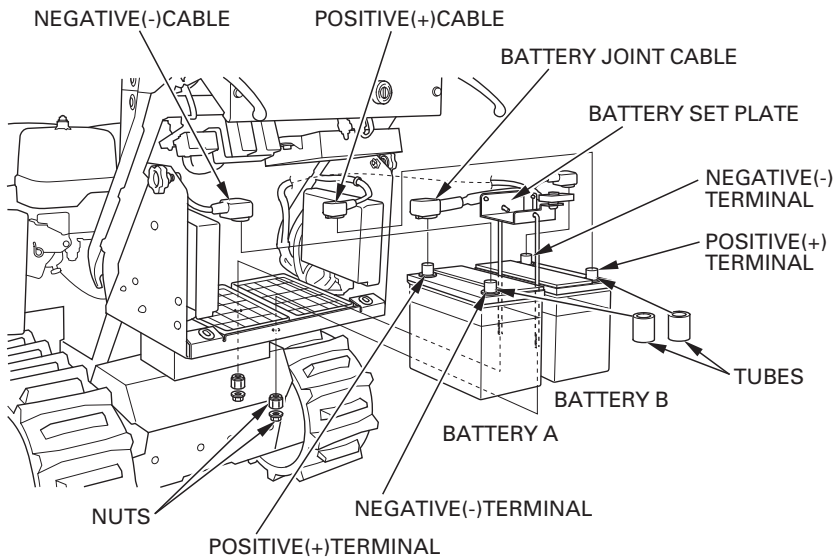

(Two 12V batteries are connected in series)

7. Remove the battery and clean the battery terminals and battery cable terminals with a wire brush or sand paper.
Clean the battery with a solution of baking soda and warm water with care not to get the solution or water in the battery cells. Dry the battery thoroughly.

SERVICING YOUR SNOWBLOWER

8. Reinstall the batteries in their original position.
9. Connect one battery joint cable terminal at the battery A positive (+) terminal, and connect the other cable terminal at the battery B negative (−) terminal.
10. Reinstall the battery set plate and tighten the nuts.
11. Connect the positive (+) cable at the battery B positive (+) terminal, and then the negative (−) cable at the battery A negative (−) terminal.
12. Coat the battery terminals with grease.
13. Reinstall the rear cover by aligning the grommets with the projections of the rear cover, and tighten the knobs securely.

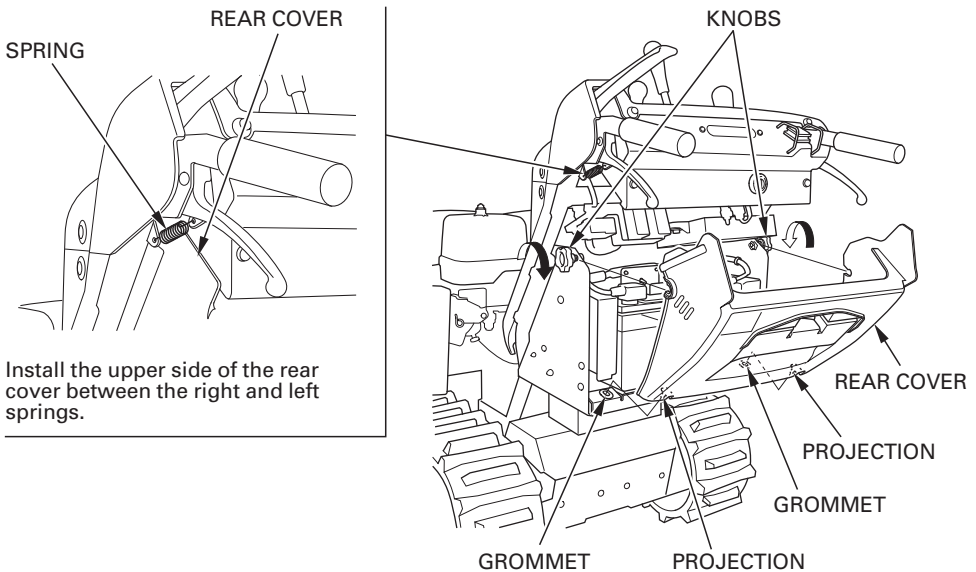

NOTICE

When disconnecting the battery cable, be sure to disconnect the battery negative (−) terminal first. Connect the positive (+) terminal first, then the negative (−) terminal. Never disconnect the battery cables in the reverse order; that could cause a short circuit if a tool contacts the terminals.

SERVICING YOUR SNOWBLOWER

Battery Charging

WARNING

The battery will expel explosive hydrogen gas when overcharged.

A spark or flame can cause the battery to explode with enough force to kill or seriously hurt you.

Always use a regulated charger that provides the correct charging current to prevent overcharging.

Wear protective clothing and a face shield, or have a skilled mechanic perform the battery maintenance.

The snowblower is equipped with two 12 V batteries connected in series (24 V total). Recharge each battery separately if you use a 12 V battery charger.

The battery is rated at 35 Ah (Ampere-hours). Charging current should equal 10% of the battery's Ampere-hour rating. A battery charger should be used that can be adjusted to deliver 3.5 amps.

1. Connect the battery charger following the manufacturer's instructions.
2. Charge the battery 5–10 hours.
3. Clean the outside of the battery and the battery tray compartment with a solution of baking soda and water.

SERVICING YOUR SNOWBLOWER

FUSE

In the event of fuse failure, locate the cause of failure and repair it before you continue operation. If the fuse continues to fail, discontinue snowblower use and consult an authorized Honda snowblower dealer.

NOTICE

Never use a fuse with a different rating from that specified. Serious damage to the electrical system or fire may result.

Block fuse replacement requires specific tools. Ask an authorized Honda snowblower dealer for replacement.

Fuse replacement (blade fuse only)

1. Remove the rear cover (see page 91).
2. Open the fuse box cover.
3. Replace the fuse as shown.
Specified fuse: 5 A, 15 A, 30 A
4. Close the fuse box cover.
5. Reinstall the rear cover (see page 93).

(Blade fuses)

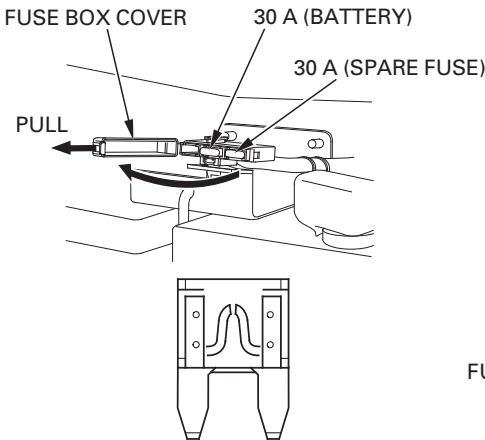

BLOWN BLADE FUSE
The 5 A and 15 A spare fuses are stored in the tool bag.

BLOCK FUSE BOXES

(Consult with your authorized Honda snowblower dealer for replacement of these fuses.)

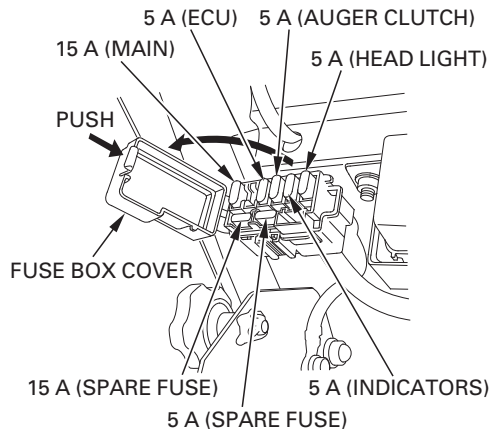
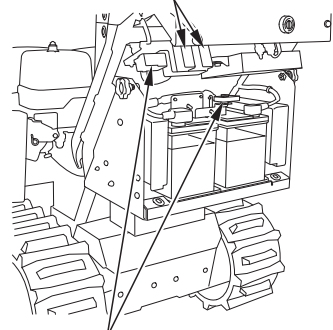

SERVICING YOUR SNOWBLOWER

(Block fuses)

Consult with your authorized Honda snowblower dealer for replacement of the block fuse (charging and drive motors).

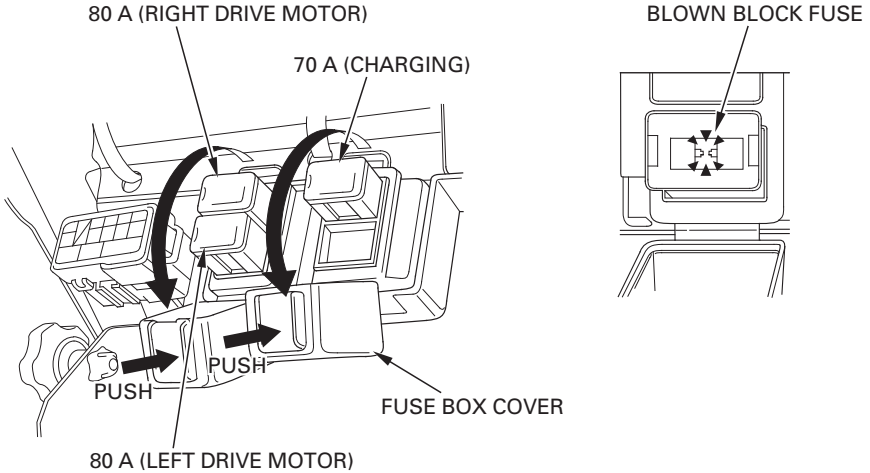

When a part of the snowblower does not operate.

- Check the fuse.
- If the fuse is normal, have your snowblower checked and repaired by your authorized Honda snowblower dealer.

Operation check

Perform the following checks every year before initial operation in the season.

- Engine for secure start and stop
- Levers for operation
- Switches for operation
- Other moving parts for operation

STORAGE

STORAGE PREPARATION

Proper storage preparation is essential for keeping your snowblower trouble-free and looking good. The following steps will help to keep rust and corrosion from impairing your snowblower's function and appearance, and will make the engine easier to start when you use the snowblower again.

Cleaning

1. Rinse the auger housing and tracks with a garden hose. Wipe the rest of the snowblower with a moist rag.
2. After the snowblower has dried, touch up any damaged paint.
3. Apply grease to the following areas for lubrication.

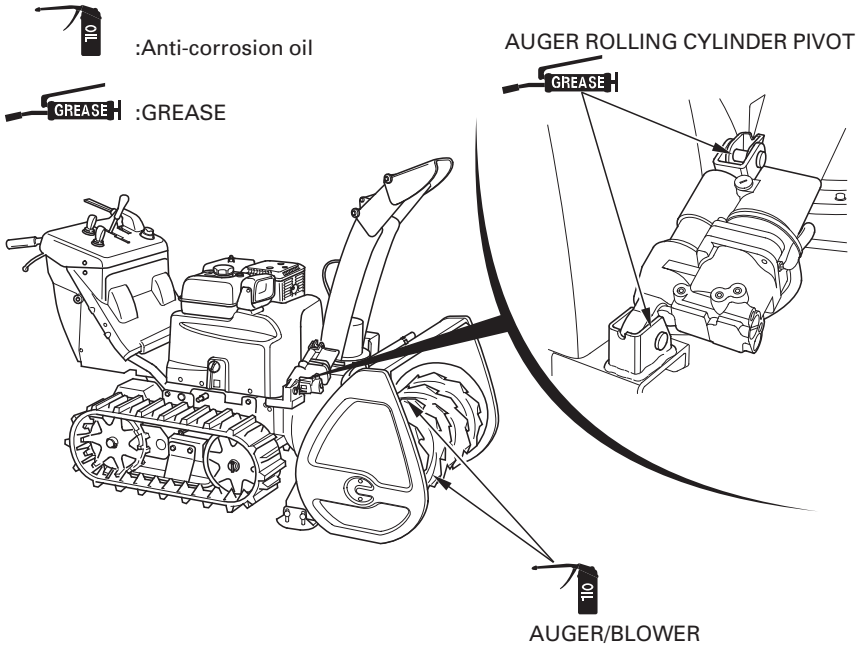

STORAGE

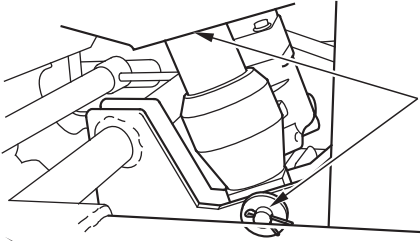

GREASE
AUGER HEIGHT
CYLINDER PIVOT

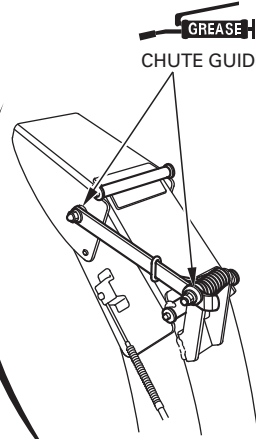

GREASE
CHUTE GUIDE LINK

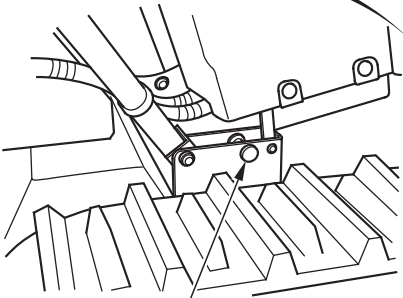
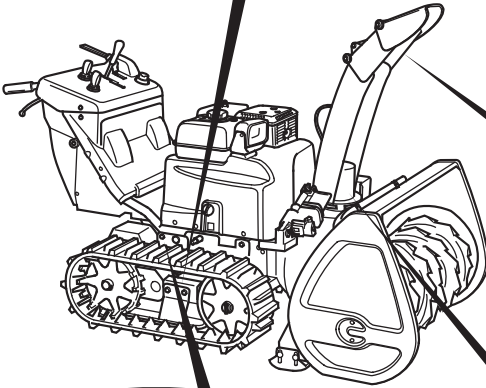

GREASE
MAIN FRAME PIVOT

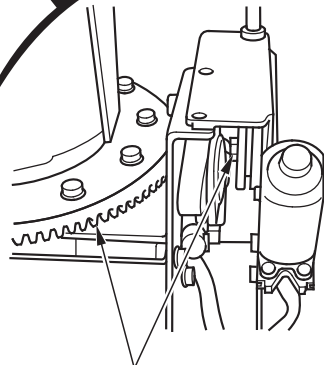

110 or GREASE
CHUTE ROLLING GEAR

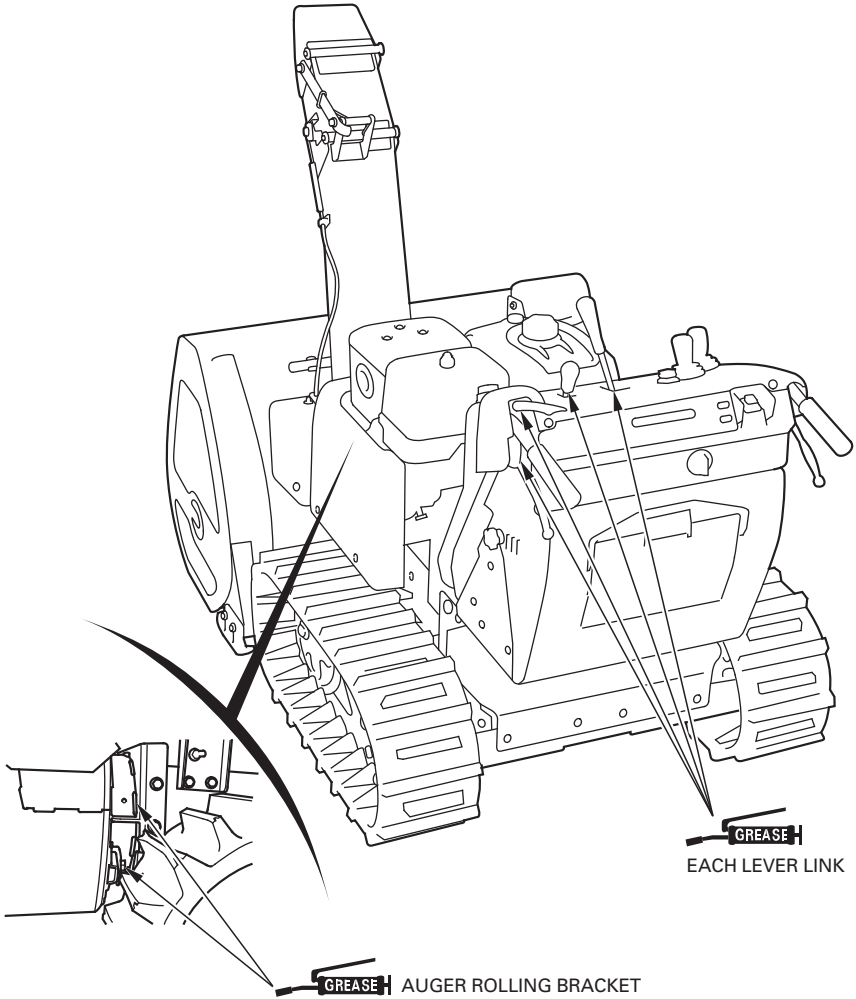

STORAGE

Fuel

NOTICE

Depending on the region where you operate your equipment, fuel formulations may deteriorate and oxidize rapidly. Fuel deterioration and oxidation can occur in as little as 30 days and may cause damage to the carburetor and/or fuel system. Please check with your servicing dealer for local storage recommendations.

Gasoline will oxidize and deteriorate in storage. Old gasoline will cause hard starting, and it leaves gum deposits that clog the fuel system. If the gasoline in your snowblower deteriorates during storage, you may need to have the carburetor and other fuel system components serviced or replaced.

The length of time that gasoline can be left in your fuel tank and carburetor without causing functional problems will vary with such factors as gasoline blend, your storage temperatures, and whether the fuel tank is partially or completely filled. The air in a partially filled fuel tank promotes fuel deterioration. Very warm storage/temperatures accelerate fuel deterioration. Fuel deterioration problems may occur within a few months, or even less if the gasoline was not fresh when you filled the fuel tank.

The *Distributor's Limited Warranty* does not cover fuel system damage or engine performance problems resulting from neglected storage preparation.

You can extend fuel storage life by adding a fuel stabilizer that is formulated for that purpose, or you can avoid fuel deterioration problems by draining the fuel tank and carburetor.

Adding a Fuel Stabilizer to Extend Fuel Storage Life

When adding a fuel stabilizer, fill the fuel tank with fresh gasoline. If only partially filled, air in the tank will promote fuel deterioration during storage. If you keep a container of gasoline for refueling, be sure that it contains only fresh gasoline.

Add fuel stabilizer following the manufacturer's instructions.

After adding a fuel stabilizer, run the engine outdoors for 10 minutes to be sure that treated gasoline has replaced the untreated gasoline in the carburetor.

Stop the engine, and move the fuel valve lever to the OFF position.

STORAGE

Draining the Fuel Tank and Carburetor

⚠ WARNING

Gasoline is highly flammable and explosive.

You can be burned or seriously injured when handling fuel.

- Stop the engine and keep heat, sparks, and flames away.
- Handle fuel only outdoors.
- Wipe up spills immediately.

1. Drain all gasoline from the fuel tank into an approved gasoline container. We recommend using a commercially available gasoline hand pump to empty the tank. Do not use an electric pump.

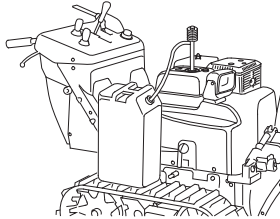

2. Turn the fuel valve lever to the ON position.
3. Loosen the carburetor drain knob and drain the gasoline into a suitable container.
4. After draining, tighten the drain knob and turn the fuel valve OFF.

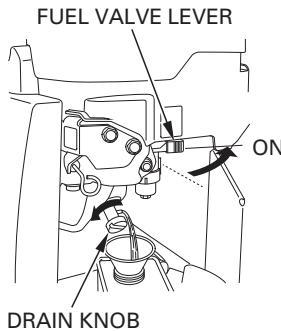

5. Remove the fuel sediment cup, O-ring and filter.
6. Empty the contents into a suitable container. Clean the fuel sediment cup and filter.
7. Reinstall the filter, new O-ring, and sediment cup; tighten the sediment cup securely.

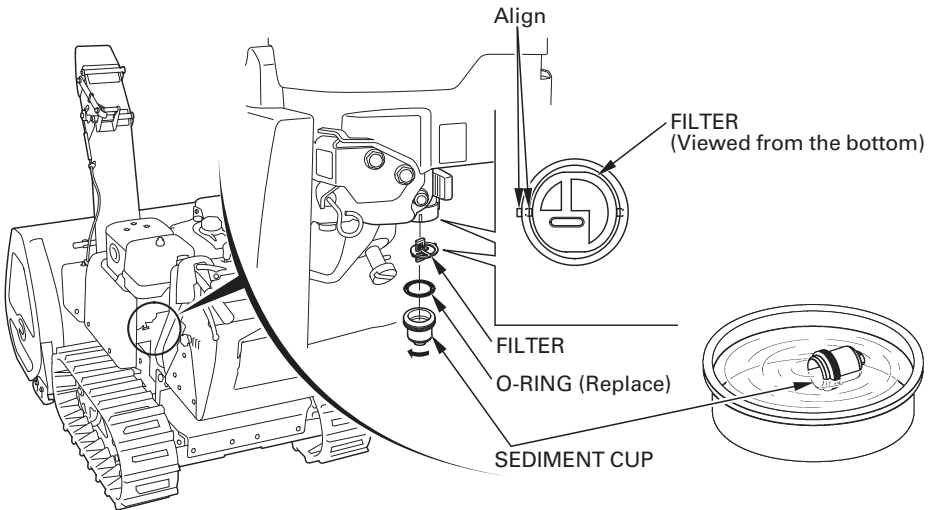

STORAGE

Engine Oil

1. Change the engine oil (see page 80).
2. Remove the spark plug (see page 82).
3. Pour 1–2 teaspoons (5–10 cm³) of clean engine oil into the cylinder.
4. Rotate the engine a few revolutions to distribute the oil in the cylinder.
5. Reinstall the spark plug.

Battery

If the snowblower will be stored for an extended period, disconnect the negative terminal from battery A. Remove the batteries and recharge them every 6 months and every year before operation and storage.

Check the battery electrolyte level (see page 89).

Charge the battery (see page 94).

STORAGE PRECAUTIONS

If your snowblower will be stored with gasoline in the fuel tank and carburetor, it is important to reduce the hazard of gasoline vapor ignition. Select a well-ventilated storage area away from any appliance that operates with a flame, such as a furnace, water heater, or clothes dryer. Also avoid any area with a spark-producing electric motor, or where power tools are operated.

If possible, avoid storage areas with high humidity, because that promotes rust and corrosion.

Unless all fuel has been drained from the fuel tank, leave the fuel valve in the OFF position to reduce the possibility of fuel leakage.

Place the snowblower on a level surface. Tilting can cause fuel or oil leakage.

With the engine and exhaust system cool, cover the snowblower to keep out dust. A hot engine and exhaust system can ignite or melt some materials. Do not use sheet plastic as a dust cover. A nonporous cover will trap moisture around the engine, promoting rust and corrosion.

REMOVAL FROM STORAGE

Check your snowblower as described in the *BEFORE OPERATION* chapter (see page 36) of this manual.

If the fuel was drained during storage preparation, fill the tank with fresh gasoline. If you keep a container of gasoline for refueling, be sure that it contains only fresh gasoline. Gasoline oxidizes and deteriorates over time, causing hard starting.

If the cylinder was coated with oil during storage preparation, the engine may smoke briefly at startup. This is normal.

TRANSPORTING

BEFORE LOADING

1. Loading the snowblower on a truck or trailer should be performed on a firm, level surface.
2. Use a loading ramp that is strong enough to support the combined weight of the snowblower and the operator:

Weight of snowblower: (Operating weight)

562 lbs (255 kg)

3. The loading ramp must be long enough so that its slope is 15° (26%) or less. Recommended ramp lengths are shown in the following table:

Length of Ramp (L)	8.2 ft (2.5 m)	9.8 ft (3.0 m)	11.5 ft (3.5 m)
Height (H)	1.6 ft (50 cm)	2.0 ft (60 cm)	2.3 ft (70 cm)

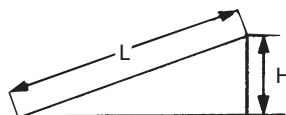

4. If the truck bed has a low roof or cover, with less than 5 ft (1.5 m) of headroom, lower the discharge deflector for better clearance, or remove the chute assembly.
5. Check that there is sufficient fuel in the tank. The engine may stall on the ramp if there is not enough fuel in the tank.

LOADING

⚠ WARNING

Spilled fuel may ignite. To avoid fuel and oil spillage, keep the snowblower level when transporting.

1. Start the engine and raise the auger fully by operating the auger control switch. And lower the chute guide fully by operating the chute control switch.
2. Set the main shift lever in the SLOW RANGE, and back the snowblower up the loading ramp at low speed.

⚠ WARNING

Do not operate the steering lever while backing the snowblower up the loading ramp; serious personal injury or damage to the snowblower could result.

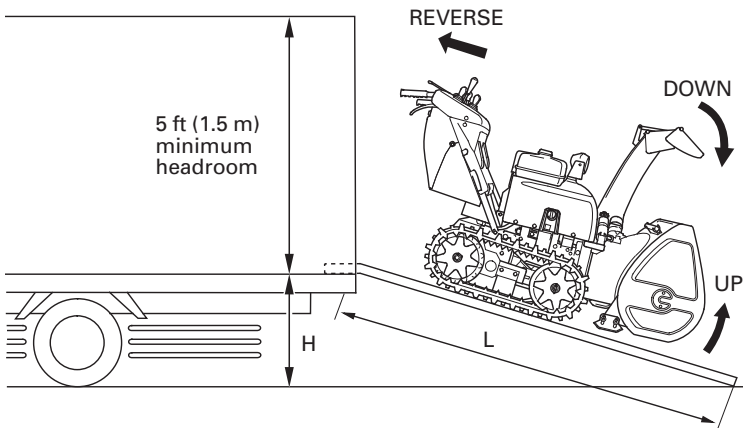

NOTICE

*Do not hang the snowblower.
Hanging the snowblower could cause damage.*

TRANSPORTING

3. After the snowblower is in the truck, stop the engine, and turn the fuel valve to the OFF position. This will prevent the possibility of carburetor flooding and will reduce the possibility of fuel leakage.
4. Tie the snowblower down with rope or straps, and block the treads. Keep the tie-down rope or straps away from controls, wire harness, and cables.

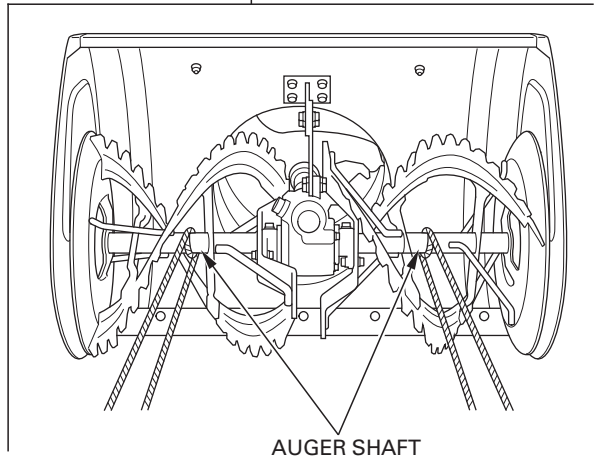
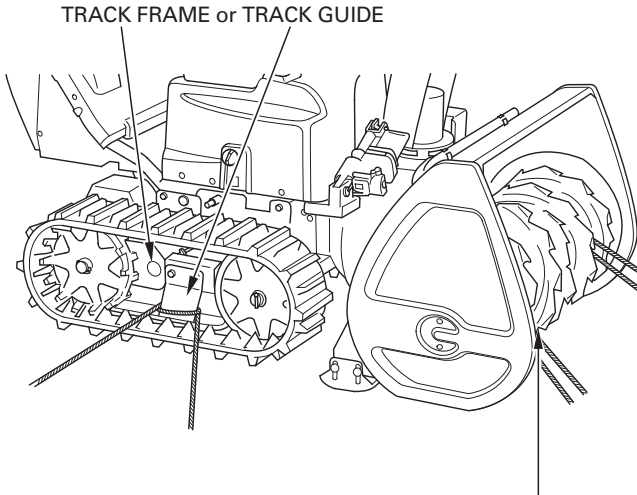

TAKING CARE OF UNEXPECTED PROBLEMS

ENGINE WILL NOT START

Electric starter does not operate	Possible cause	Correction
Check the battery.	Battery connections loose or corroded.	Clean and tighten battery connections (page 92).
	Battery discharged.	Recharge battery (page 94).
Check the fuses.	Fuse(s) blown.	Replace fuse(s)(page 95).
Check the engine oil level.	Oil indicator comes on. Low engine oil level.	Add oil.

Starter operates, but engine will not start	Possible cause	Correction
Check the drive clutch lever position.	Drive clutch lever is squeezed.	Release the drive clutch lever (page 69).
Check the auger clutch switch position.	Auger clutch switch is ON position.	Auger clutch switch is OFF position (page 23).
Check fuel delivery to engine.	Fuel valve lever is OFF.	Turn fuel valve lever to ON (page 39).
	Sediment cup obstructed.	Check for contaminants in sediment cup (page 103).
Check fuel condition.	Stale or old fuel.	Be sure tank has fresh fuel. Drain carburetor and sediment cup (page 102).
Check for spark.	Spark plug cap off.	Make sure cap is connected.
	Improper electrode gap or deposits in the spark plug gap.	Verify that spark plug is free of deposits, and has proper gap (page 83).
Check the manual start lever.	Stuck the auto choke system by a foreign material (ice, etc.).	Pushing the manual start lever (page 40).

TAKING CARE OF UNEXPECTED PROBLEMS

If the engine still does not start, take the snowblower to an authorized Honda snowblower dealer.

- If the drive control warning indicator (orange) comes on and blinks during driving and it does not go off after restarting the engine, have your snowblower checked by your authorized Honda snowblower dealer promptly.
- If the drive control warning indicator (red) blinks during driving, move the snowblower to a safe place and stop the engine. Wait for a while and restart the engine. The snowblower is normal if the drive control indicator goes off after the engine starts. If it does not, have your snowblower checked by your authorized Honda snowblower dealer.

TAKING CARE OF UNEXPECTED PROBLEMS

SELF-DIAGNOSIS FUNCTION

When a trouble occurs

When a trouble occurs to the snowblower during running, the drive control warning indicator (orange) repeatedly blinks a number that corresponds to the type of trouble. Turn the engine switch to the STOP position and turn it to the ON position again. If the snowblower is faulty, the drive control warning indicator (red) comes on and the drive control warning indicator (orange) repeats blinking the number that corresponds to the type of trouble (see pages 112 and 113).

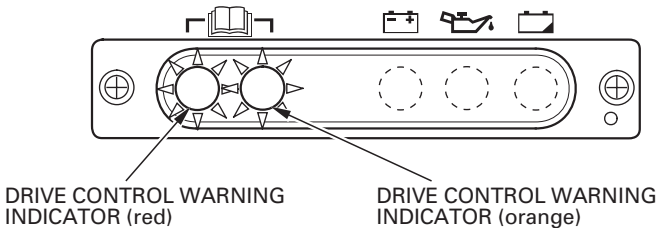

- The drive control warning indicator (orange) comes on for 0.5 seconds, then it goes off for 0.5 seconds. It repeatedly blinks a number corresponding to the type of trouble, then it goes off for 3 seconds. The drive control warning indicator (orange) repeats this cycle of blinking and going off.

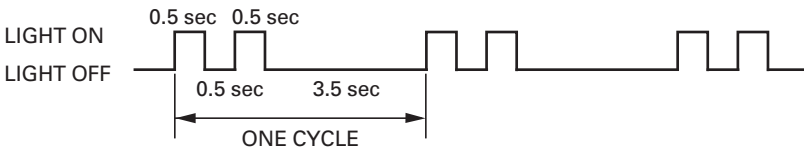

Example: When the indicator blinks twice:

It comes on for 0.5 seconds, goes off for 0.5 seconds, comes on for 0.5 seconds again, and then goes off for 3.5 seconds. The indicator repeats this cycle of operation.

TAKING CARE OF UNEXPECTED PROBLEMS

Check whether the drive control warning indicator (orange) comes on and check the number of blinks.

Failure diagnosis

WARNING INDICATOR		SYMPTOM	POSSIBLE CAUSE	REMEDY
(RED)	(ORANGE)/ BLINKING TIMES			
Light on continuously	Light off	Indicator blowout or main ECU failure	Indicator blowout or main ECU failure	Consult with your authorized Honda dealer.
	2 times	Main ECU failure	EEPROM failure	
	3 times	Sensor failure	Main shift lever sensor or steering lever sensor or main ECU or auger clutch switch or drive clutch switch wire broken or short circuit.	
	4 times	Driver failure-Right	Main ECU or right motor driver wire broken.	
	5 times	Motor rotating sensor failure-Right	Main ECU or right drive motor wire broken.	
	6 times	Driver failure-Left	Main ECU or left motor driver wire broken.	
	7 times	Motor rotating sensor failure-Left	Main ECU or left drive motor wire broken.	

TAKING CARE OF UNEXPECTED PROBLEMS

Failure diagnosis (continued)

WARNING INDICATOR		SYMPTOM	POSSIBLE CAUSE	REMEDY
(RED)	(ORANGE)/ BLINKING TIMES			
Light on continuously	8 times	Electromagnetic brake or auger clutch failure	Breaking of coil or wire or short circuit.	Consult with your authorized Honda dealer.
	10 times * 1:	Abnormal battery	Battery is dead.	
	11 times	Motor protection system/Abnormal	Motor overheat.	Stop the engine, wait 5 min. Restart. * 2:
	12 times	Motor temperature sensor	Drive motor or main ECU or engine ECU wire broken.	Consult with your authorized Honda dealer.
	13 times	Engine throttle lever sensor failure	Throttle lever sensor wire broken.	
	14 times	Abnormal between main ECU and engine ECU communication or ACG. Engine ECU EEPROM or microcomputer failure	Abnormal from engine i-GOV to main ECU. Wire broken. Engine i-GOV internal failure.	

* 1: The battery indicator blinks.

* 2: Consult with your authorized Honda snowblower dealer if the drive control warning indicator (orange) keeps blinking after restarting the engine.

If you notice any abnormality with the snowblower, consult with your authorized Honda snowblower dealer.

TAKING CARE OF UNEXPECTED PROBLEMS

Blinking (green) of reset button indicator

Indicator (green)	SYMPTOM	POSSIBLE CAUSE	REMEDY
Blink	Reset operation failure of auger housing	Height sensor wire broken or short circuit. Roll sensor wire broken or short circuit.	Consult with your authorized Honda dealer.

TAKING CARE OF UNEXPECTED PROBLEMS

(1) Engine does not start.

SYMPTOM	POSSIBLE CAUSE	REMEDY
Fuel is not reaching the carburetor.	There is no gasoline in the fuel tank.	Refuel (see page 77).
	Fuel valve lever is not opened.	Turn the fuel valve lever to the "ON" position (see page 39).
	No fuel flow.	Check flow by loosening the drain screw.
	Fuel filter is clogged.	Consult an authorized Honda dealer.
	Fuel pipe arrangement is frozen.	
Fuel is reaching the carburetor.	Carburetor is flooded.	
	Carburetor is clogged.	
	Gasoline spoiled.	Refuel with fresh gasoline. Drain fuel tank and carburetor (see page 102). Refuel (see page 77).
	Gasoline contains water.	
Starter motor does not operate.	Battery is dead.	Charge the battery or replace (see page 91 and 94).
	Fuse is blown.	Replace the fuse (see page 95).
	Battery terminal is disconnected.	Connect the battery terminal (see page 93).
	Drive clutch lever is squeezed or auger clutch switch is pressed when starting.	Release the drive clutch lever and do not press the auger clutch switch (see page 69).
	No or low oil level.	Check the engine oil level and add oil to the upper level if necessary (see page 79).

TAKING CARE OF UNEXPECTED PROBLEMS

Starter motor operates.	Fouled spark plug.	Clean or replace the spark plug (see page 82).
	Loose spark plug cap.	Install the spark plug cap securely (see page 82).
	Spark plug is damaged.	Replace the spark plug (see page 82).
	Frozen auto choke system.	Auto choke malfunction can be suspected. Restart the engine by operating the manual start lever (see page 40).
	Warning indicator is on.	Turn the engine switch to the OFF position and turn it to the ON position again. If the indicator comes on again, the starter motor can be faulty. Consult with your authorized Honda snowblower dealer.

TAKING CARE OF UNEXPECTED PROBLEMS

(2) It runs poorly

SYMPTOM	POSSIBLE CAUSE	REMEDY
Hard to drive the snowblower in forward direction.	Auger shear bolt is broken.	Replace the auger shear bolt (see page 86).
	Auger height is not properly adjusted.	Auger height adjustment (see page 45).
	Snow is clogged in the snowblowing mechanism.	Use the snow drop bar to remove the snow (see page 68).
Snowblower does not run.	Drive motor overheated by operation under excessive load, which armed the protection function.	Turn the engine switch to the OFF position and wait for a while before turning it to the ON position again.
Snowblower runs slowly.	To prevent malfunction resulting from drive motor overheating, the drive power is reduced.	Turn the engine switch to the "OFF" position and wait for a while before turning it to the "ON" position again.
Hard to drive the snowblower in reverse direction.	Auger height is not adjusted in the HIGH position.	Auger height adjustment (see page 45).
Snowblower does not move when squeezing the drive clutch lever.	Wheel pin in the track has worked off.	Consult an authorized Honda dealer.
	Warning indicator (orange) blinks or comes on.	Count the number of times the warning indicator (orange) blinks (see page 112 and 113), then consult an authorized Honda dealer.
Steering lever does not work at all (or it does not work well).	Snowblowing mechanism is buried in deep snow.	Operate the main shift lever to the slower position, squeeze the steering lever and apply some force on the handle to turn in the direction you want.
		Lift up the snow blowing mechanism, then squeeze the steering lever.
	Track does not stop or become slower when squeezing the steering lever.	Steering lever sensor or drive motor might be faulty. Consult an authorized Honda dealer.

TAKING CARE OF UNEXPECTED PROBLEMS

SYMPTOM	POSSIBLE CAUSE	REMEDY
Traveling speed becomes too low to clear the snow when the auger clutch switch is turned to the ON position.	Engine speed is not stable and load control function is on.	<ul style="list-style-type: none"> • Turn the engine switch to the STOP position and start the engine again. Start clearing the snow after the engine speed is stabilized. • If the problem is not resolved six seconds later and the indicator (orange) blinks, consult with your authorized Honda snowblower dealer.
Hard to make a turn on the spot.	Main shift lever is not set in Low speed position.	Set the main shift lever in the Forward Low speed position and squeeze the steering lever fully (see page 58).
	Steering lever was not squeezed enough.	
Battery run system does not work.	Battery run system has not been turned on.	Squeeze both the right and left steering levers for 3 seconds simultaneously.
	Drive control warning indicators (red and orange) are on at 5 seconds after driving the snowblower with the battery power.	Turn the engine switch to the OFF position and operate battery run system once again.
	Battery is dead.	Charge the battery or replace it if necessary. (see page 91 and 94).
Warning indicator (orange) blinks or comes on.	Electric equipment is abnormal, or broken.	Count the number of times indicator blinks (see page 112 and 113).
		Consult an authorized Honda dealer.

- It is difficult to operate the snowblower in deep, soft snow.
Drive the snowblower in low speed to avoid slipping or push and pull the handle to get out of deep, soft snow.
- Leavering the engine switch in the ON position will waste the battery, and the engine will not start.
After operating the battery run system, make sure you always turn the engine switch to the OFF position.
- When consulting an authorized Honda dealer, make sure to inform him or her of the number of times warning indicator (orange) blinks.

TAKING CARE OF UNEXPECTED PROBLEMS

(3) Can not clear snow well.

SYMPTOM	POSSIBLE CAUSE	REMEDY
Hard to drive the snowblower in the forward direction while clearing the snow.	Auger shear bolt is broken.	Replace the auger shear bolt (see page 86).
	Auger housing height is not adjusted properly.	Adjust the auger housing height in the proper position (see page 45).
	Snow is stuck in the auger and the related parts of the snowblower.	Remove the snow from the underside of the auger housing (see page 68).
Snow does not come out from the snow discharge chute.	Snow discharge chute is clogged.	Use the snow clearing bar and remove the snow from the snow discharge chute (see page 68).
Hard to collect the snow to clear.	Snow is stuck on the auger.	Remove the snow from the auger and the related parts (see page 68).
Blower does not rotate.	Blower shear bolt is broken.	Replace the blower shear bolt (see page 86).
	Drive motor overheated by operation under excessive load, which armed the protection function.	Turn the engine switch to the OFF position and wait for a while before turning it to the ON position again. Motor protection function (see page 60).
	Blower does not rotate when pressing the auger clutch switch.	Switch or electromagnetic clutch might be faulty. Consult with an authorized Honda dealer.
Auger does not rotate.	Auger shear bolt is broken.	Replace the auger shear bolt (see page 86).
	Drive motor overheated by operation under excessive load, which armed the protection function.	Turn the engine switch to the OFF position and wait for a while before turning it to the ON position again. Motor protection function (see page 60).
	Blower does not rotate when pressing the auger clutch switch.	Switch or electromagnetic clutch might be faulty. Consult an authorized Honda dealer.

TAKING CARE OF UNEXPECTED PROBLEMS

SYMPTOM	POSSIBLE CAUSE	REMEDY
Snow discharge chute does not throw snow well.	Engine is overloaded. [MANUAL mode only]	Lower the driving speed (see page 65).
	Engine speed is too low. [MANUAL and POWER mode only]	Move the throttle control lever to the FAST position (see page 52 or 55).
	Blower is deformed.	Replace the blower (see page 87).
	Blower shear bolt is broken.	Replace the blower shear bolt (see page 86).
	Auger shear bolt is broken.	Replace the auger shear bolt (see page 86).
	Snow discharge chute is angled down.	Adjust so that the snow discharge chute is angled up (see page 25).
Auger runs up onto and does not cut into hard snow. Auger housing becomes clogged with snow.	Auger height is not proper.	Adjust the auger height (see page 45).
	Auger shear bolt is broken.	Replace the auger shear bolt (see page 86).
	Auger is worn.	Replace the auger (see page 87).
	Blower shear bolt is broken.	Replace the blower shear bolt (see page 86).
	The height of skid and scraper is not proper.	Adjust the skid and scraper (see page 43-44).
Auger is in contact with the road surface.	Auger height is not adjusted properly.	Adjust the auger height (see page 45).
	Skid and scraper height is not adjusted properly.	Adjust the skid and scraper (see page 43-44).
Snowblowing mechanism makes an abnormal noise.	The shape of the shaft and wing of the auger and/or blower is deformed.	Consult an authorized Honda dealer.
Snow discharge chute direction can not be set.	Right control unit is faulty.	Consult an authorized Honda dealer.
	Motor is overheated (breaker tripped).	Wait for a while. Do not keep pushing operation lever.
	Motor or switch or relay is faulty.	Consult an authorized Honda dealer.

TAKING CARE OF UNEXPECTED PROBLEMS

SYMPTOM	POSSIBLE CAUSE	REMEDY
Auger housing height / rolling does not operate.	Auger control switch has been operated frequently.	Wait for a while and operate the switch again (see page 26).
Drive control warning indicator (orange) blinks or stays on.	Electric system is abnormal or faulty.	Check the drive control warning indicator (orange) for the number of blinks (see page 112 and 113). Consult with your authorized Honda dealer. * 1:

- If the snow depth is less than 2 inches (5 cm) deep, shift to a faster speed for more efficient snow throwing.

* 1: Tell your authorized Honda snowblower dealer about the number of blinks of the drive control warning indicator (orange).

(4)Other troubles

SYMPTOM	POSSIBLE CAUSE	REMEDY
Unable to adjust the auger height.	Auger power height adjusting part is overheated.	Internal protection circuit is armed when the auger power height adjusting part is overheated by frequent application of the auger control switch.Wait for a while and operate the switch again.
	Auger power height adjusting part is faulty.	Consult an authorized Honda dealer.
Track is worked off from the wheels.	Track is loosened.	Check and adjust the deflection of the track (see page 84).
Headlight does not turn on.	Battery is dead.	Charge or replace the battery (see page 91 and 94).
	Fuse is blown out.	Replace the fuse (see page 95).
	Bulb in the headlight is out.	Consult with an authorized Honda dealer.

TAKING CARE OF UNEXPECTED PROBLEMS

JUMP STARTING

Start the engine using the two 12V booster batteries, which are connected in series.

1. Connect jumper cable A to the positive (+) terminal (1) on booster battery A. Connect the other end to the negative (-) terminal (2) on booster battery B.
2. Connect jumper cable B to the positive (+) terminal (3) on the snowblower. Connect the other end to the positive (+) terminal (4) on booster battery B.
3. Connect jumper cable C to the negative (-) terminal (5) on booster battery A. Connect the other end to the ground bolt (6) on the snowblower.
4. Start the engine (see page 39).
5. Remove the jumper cables in the reverse order.

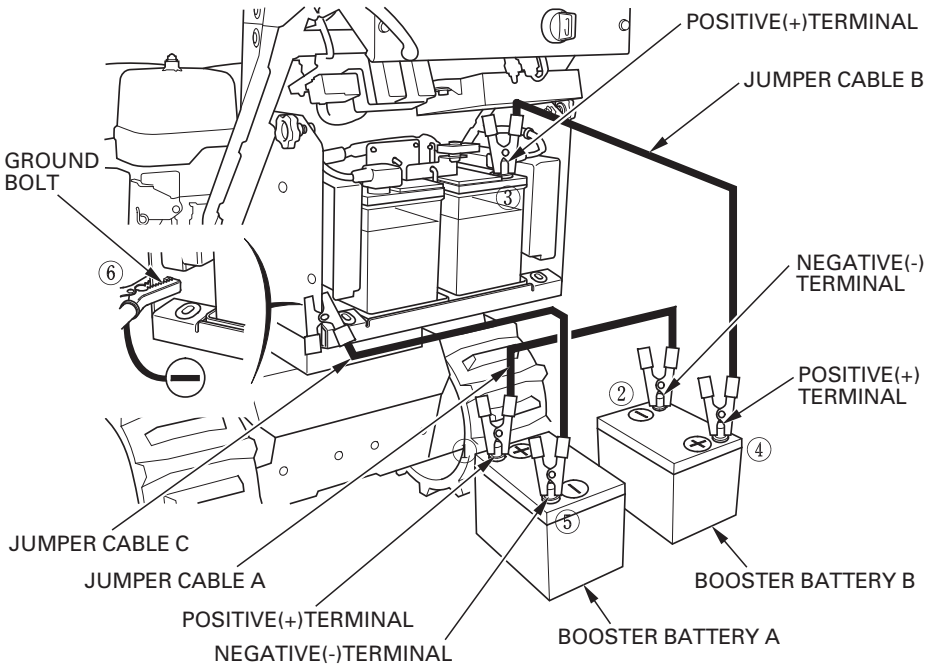

(Two 12 V batteries are connected in series)

TAKING CARE OF UNEXPECTED PROBLEMS

NOTICE

- *When disconnecting the battery cable, be sure to disconnect at the battery negative (–) terminal first. To connect, connect at the positive (+) terminal first, then at the negative (–) terminal. Never disconnect the battery cable in the reverse order, or you may cause a short circuit if a tool contacts the positive terminal.*
- *When you replace the battery, do it in pairs.*

TAKING CARE OF UNEXPECTED PROBLEMS

EMERGENCY TRANSPORT

You can move the snowblower by pushing or pulling it without engine power.

Place the snowblower on the level ground after transportation and use a new cotter pin when replacing the wheel pin.

1. Remove the cotter pins from the rear right and left wheels.
2. Remove the wheel pins from the rear right and left wheels.
3. The track rotates freely, allowing the operator to move the snowblower without engine power.

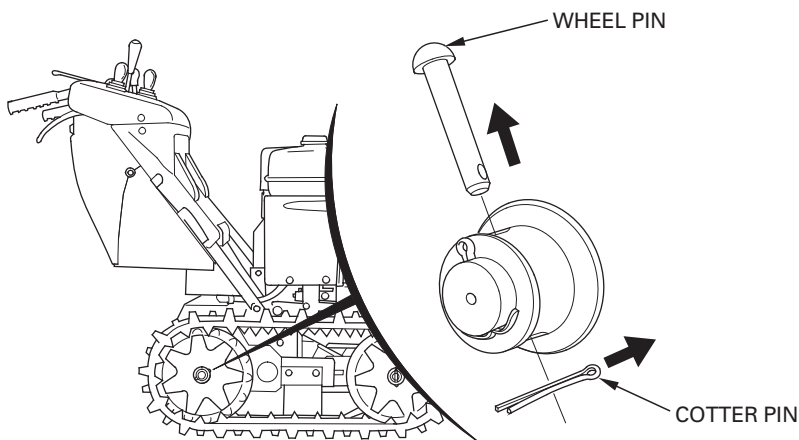

⚠ WARNING

Before removing the wheel pins, make sure to stop the rotating parts, stop the engine and remove the engine switch key.

Do not remove the wheel pins on the slope. The snowblower may move unintentionally, causing injury.

TECHNICAL INFORMATION

Serial Number Locations

Record the engine and frame serial numbers and date of purchase in the spaces below. You will need these serial numbers when ordering parts and when making technical or warranty inquiries (see page 132).

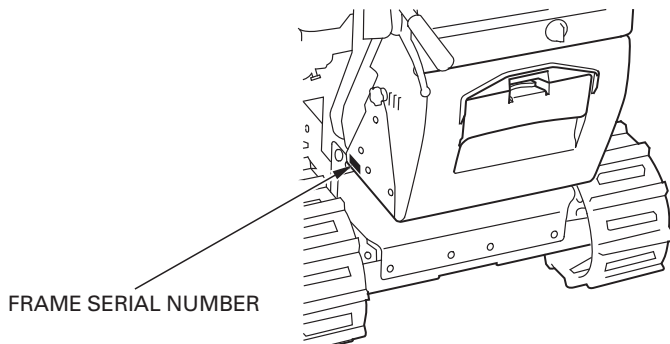
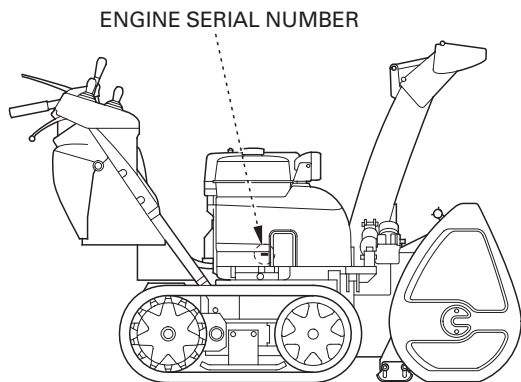

Engine serial number: _____

Frame serial number: _____

Date of purchase: _____

TECHNICAL INFORMATION

Carburetor Modification for High Altitude Operation

At high altitude, the standard carburetor air-fuel mixture will be too rich. Performance will decrease, and fuel consumption will increase. A very rich mixture will also foul the spark plug and cause hard starting. Operation at an altitude that differs from that at which this engine was certified, for extended periods of time, may increase emissions.

High altitude performance can be improved by specific modifications to the carburetor. If you always operate your snowblower at altitudes above 5,000 feet (1,500 meters) have your servicing dealer perform this carburetor modification. This engine, when operated at high altitude with the carburetor modifications for high altitude use, will meet each emission standard throughout its useful life.

Even with carburetor modification, engine horsepower will decrease about 3.5% for each 1,000-foot (300-meter) increase in altitude. The effect of altitude on horsepower will be greater than this if no carburetor modification is made.

NOTICE

When the carburetor has been modified for high altitude operation, the air-fuel mixture will be too lean for low altitude use. Operation at altitudes below 5,000 feet (1,500 meters) with a modified carburetor may cause the engine to overheat and result in serious engine damage. For use at low altitudes, have your servicing dealer return the carburetor to original factory specifications.

Emission Control System Information

Source of Emissions

The combustion process produces carbon monoxide, oxides of nitrogen, and hydrocarbons. Control of hydrocarbons and oxides of nitrogen is very important because, under certain conditions, they react to form photochemical smog when subjected to sunlight. Carbon monoxide does not react in the same way, but it is toxic.

Honda utilizes appropriate air/fuel ratios and other emissions control systems to reduce the emissions of carbon monoxide, oxides of nitrogen and hydrocarbons.

Additionally, Honda fuel systems utilize components and control technologies to reduce evaporative emissions.

The U.S. and California Clean Air Act

EPA and California regulations require all manufacturers to furnish written instructions describing the operation and maintenance of emission control systems.

The following instructions and procedures must be followed in order to keep the Honda engine emissions within the emission standards.

Tampering and Altering

NOTICE

Tampering is a violation of Federal and California law.

Tampering with or altering the emission control system may increase emissions beyond the legal limit. Among those acts that constitute tampering are:

- Removal or alteration of any part of intake, fuel or exhaust system.
- Altering or defeating the governor linkage or speed-adjusting mechanism to cause the engine to operate outside its design parameters.

TECHNICAL INFORMATION

Problems That May Affect Emissions

If you are aware of any of the following symptoms, have your engine inspected and repaired by your authorized Honda servicing dealer.

- Hard starting or stalling after starting.
- Rough idle.
- Misfiring or backfiring under load.
- Afterburning (backfiring).
- Black exhaust smoke or high fuel consumption.

Replacement parts

The emission control systems on your new Honda engine were designed, built, and certified to conform with EPA and California emission regulations. We recommend the use of Honda Genuine parts whenever you have maintenance done. These original-design replacement parts are manufactured to the same standards as the original parts, so you can be confident of their performance. The use of replacement parts that are not of the original design and quality may impair the effectiveness of your emission control system.

A manufacturer of an aftermarket part assumes the responsibility that the part will not adversely affect emission performance. The manufacturer or rebuilder of the part must certify that use of the part will not result in a failure of the engine to comply with emission regulations.

Maintenance

Follow the *Maintenance Schedule* on page 76. Remember that this schedule is based on the assumption that your machine will be used for its designed purpose. Sustained high-load operation will require more frequent service.

Air Index

An Air Index Information label is applied to engines certified to an emission durability time period in accordance with the requirements of the California Air Resources Board.

The bar graph is intended to provide you, our customer, the ability to compare the emissions performance of available engines. The lower the Air Index, the less pollution.

The durability description is intended to provide you with information relating to the engine's emission durability period. The descriptive term indicates the useful-life period for the engine's emission control system. See your *Emission Control Warranty* for additional information.

Descriptive Term	Applicable to Emission Durability Period
Moderate	50 hours (0 – 80 cc, inclusive) 125 hours (greater than 80 cc)
Intermediate	125 hours (0 – 80 cc, inclusive) 250 hours (greater than 80 cc)
Extended	300 hours (0 – 80 cc, inclusive) 500 hours (greater than 80 cc) 1,000 hours (225 cc and greater)

TECHNICAL INFORMATION

Specifications

Frame

Model	HS1336i
Items	Type A
Discription code	SBAJ
Overall length	69.3 in (1,760 mm)
Overall width	36.2 in (920 mm)
Overall height	52.8 in (1,340 mm)
Dry mass [weight]	540 lbs (245 kg)
Width of snow clearance	36.2 in (920 mm)
Height of snow clearance	22.8 in (580 mm)
Snow throwing distance (varies with snow conditions)	Max. 59.1 ft (19 m)
Clearing capacity	83 Ton/hour

Engine

Model	Honda GX390
Displacement	23.7 cu-in (389 cm ³)
Bore × stroke	3.46 × 2.52 in (88.0 × 64.0 mm)
Starting method	Electric starter
Ignition system	CDI magneto
Oil capacity	1.16 US qt (1.1 L)
Fuel tank capacity	1.5 US gal (5.7 L)
Spark plug	BPR5ES (NGK) W16EPR-U (DENSO)
Battery	12 V 35 Ah/20 HR × 2 (connect in series)

Tuneup

ITEM	SPECIFICATION	MAINTENANCE
Spark plug gap	0.028–0.031 in (0.7–0.8 mm)	Refer to page: 82
Valve clearance	IN: 0.15 ± 0.02 mm EX: 0.20 ± 0.02 mm	See your authorized Honda dealer
Other specifications	No other adjustments needed.	

Specifications are subject to change without notice.

CONSUMER INFORMATION

Dealer Locator Information

To find an authorized Honda Servicing Dealer anywhere in the United States:

Visit our web site:

<http://powerequipment.honda.com/dealer-locator> and click on Dealer Locator.

Honda Publications

Shop Manual

This manual covers complete maintenance and overhaul procedures. It is intended to be used by a skilled technician.

Available through your Honda dealer or through Helm Inc. at 1 (888) 292-5395 or visit

<http://powerequipment.honda.com/support/shop-manuals>

Parts Catalog

This manual provides complete, illustrated parts lists. Available through your Honda dealer.

CONSUMER INFORMATION

Customer Service Information

Honda Power Equipment dealership personnel are trained professionals. They should be able to answer any question you may have. If you encounter a problem that your dealer does not solve to your satisfaction, please discuss it with the dealership's management. The Service Manager or General Manager can help. Almost all problems are solved in this way.

If you are dissatisfied with the decision made by the dealership's management, contact the Honda Power Equipment Customer Relations Office. You can write:

American Honda Motor Co., Inc.
Power Equipment Division
Customer Relations Office
4900 Marconi Drive
Alpharetta, Georgia 30005-8847

Or telephone: (770) 497-6400 M-F, 8:30 am to 7:00 pm ET

When you write or call, please give us this information:

- Model and serial number (see page 125)
- Name of the dealer who sold the snowblower to you
- Name and address of the dealer who services your snowblower
- Date of purchase
- Your name, address, and telephone number
- A detailed description of the problem

QUICK REFERENCE INFORMATION

Fuel	Type	Unleaded gasoline with an ethanol content of no more than 10% and a pump octane rating of 86 or higher
Engine Oil	Type	SAE 5W-30 API SJ or later for general use
Spark Plug	Type	BPR5ES (NGK) W16EPR-U (DENSO)
Maintenance	Before each use, check the following.	Engine oil level. Battery electrolyte level. Check the auger skid and scraper. Check the auger and blower shear bolt. Check the all nuts and bolts.
	First 20 hours	Change engine oil. Check the track.
	Subsequent	See Maintenance Schedule (page 76)

HONDA

The Power of Dreams

