



Quick Start Guide

Pro 28 (926038 s/n 75000 & up)

- Step 1: Unfold Handlebar
- Step 2: Install Discharge Chute
- Step 3: Install Chute Control Assembly
- Step 4: Install Discharge Chute Rod
- Step 5: Install Remote Deflector Cable
- Step 6: Check Function of Dual Handle Interlock
- Step 7: Check Tire Pressure
- Step 8: Adjust Skid Shoes
- Step 9: Check Auger Gearcase Oil
- Step 10: Check Engine Crankcase Oil
- Step 11: Fill Engine Fuel Tank
- Step 12: Start Engine
- Step 13: Stop Engine



READ AND UNDERSTAND ALL INSTRUCTION, WARNING, AND DANGER LABELS.

IMPORTANT: READ OPERATOR'S MANUAL AND ENGINE MANUAL THOROUGHLY AND FOLLOW THE IMPORTANT SAFE OPERATION PRACTICES BEFORE OPERATING.



Step One: Unfold Handlebar

1. Remove the lower and loosen the upper hardware on the handlebar assembly.
2. Loosen the hardware on the shift rod.
3. Put the speed selector lever in the second reverse position.
4. Rotate the handlebar into operating position.

NOTE: The handlebar has two height positions. Adjust the handlebar height to provide better operator comfort. See *Handlebar Height* in Owner Manual.

5. Install and tighten the hardware on the handlebar assembly and shift rod.
6. Check tension on auger and traction clutch cables.

IMPORTANT: Cables should not be slack nor under tension. Adjust as necessary.

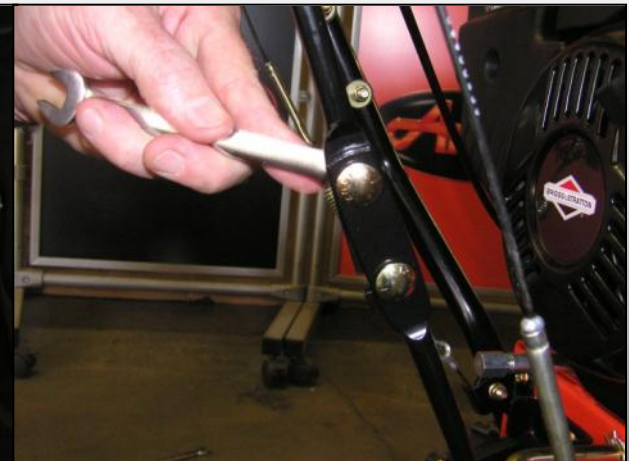
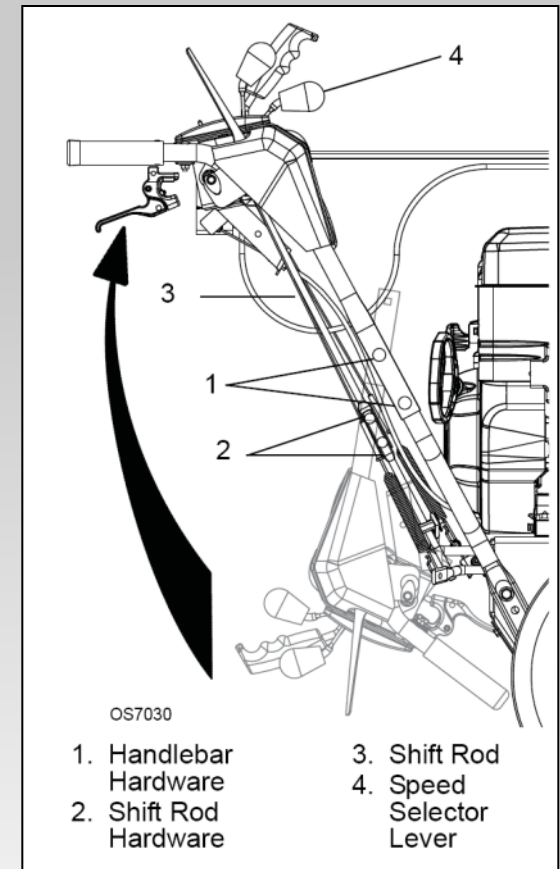



Step Two: Install Discharge Chute

1. Grease underside of discharge chute ring (if not already greased).
2. Remove mounting hardware from auger housing.
3. Install discharge chute over opening in the auger housing. Finger tighten the mounting hardware removed above.

NOTE: Leave discharge chute pedestal loose to help install the chute rod.

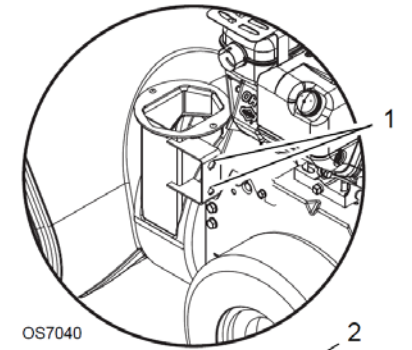

OS7040

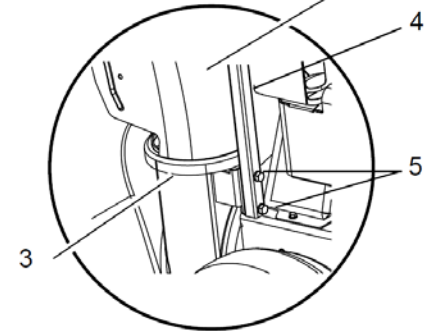

1. Mounting Holes
2. Discharge Chute
3. Discharge Chute Ring
4. Chute Pedestal
5. Mounting Hardware

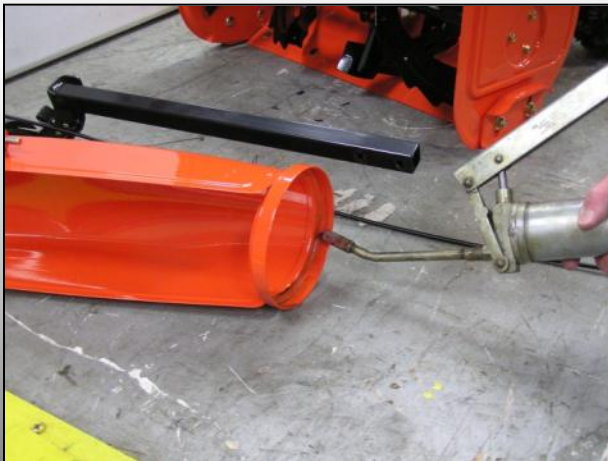



Step Three: Install Chute Control Assembly

1. Remove the gear cover from top of chute pedestal.
2. Release the lock teeth on the gear assembly with your finger and rotate the discharge chute so it points straight ahead.

NOTE: Make sure alignment markers are lined up when discharge chute is pointing straight ahead.

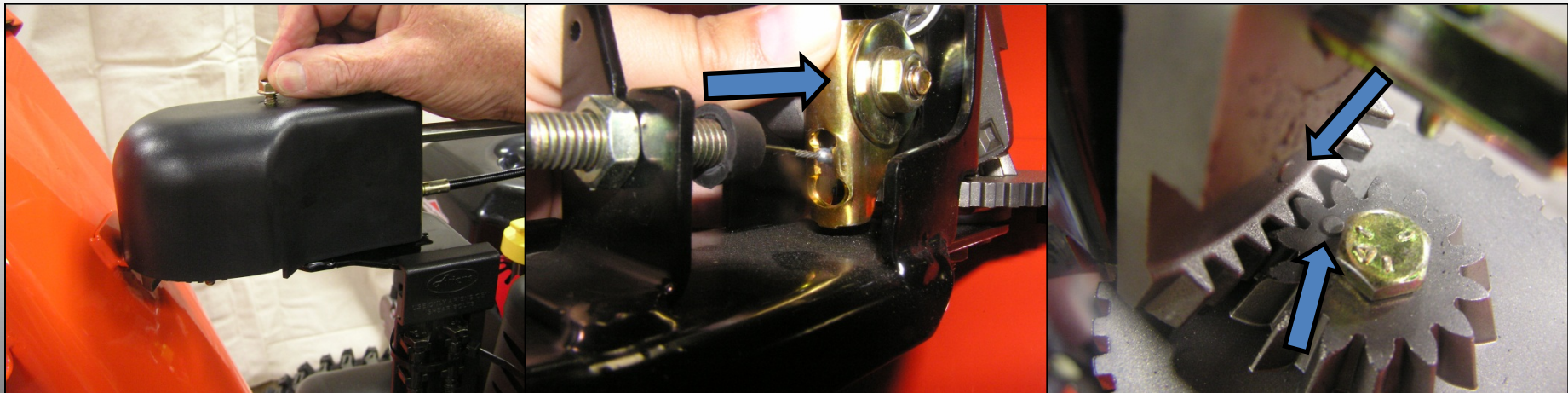
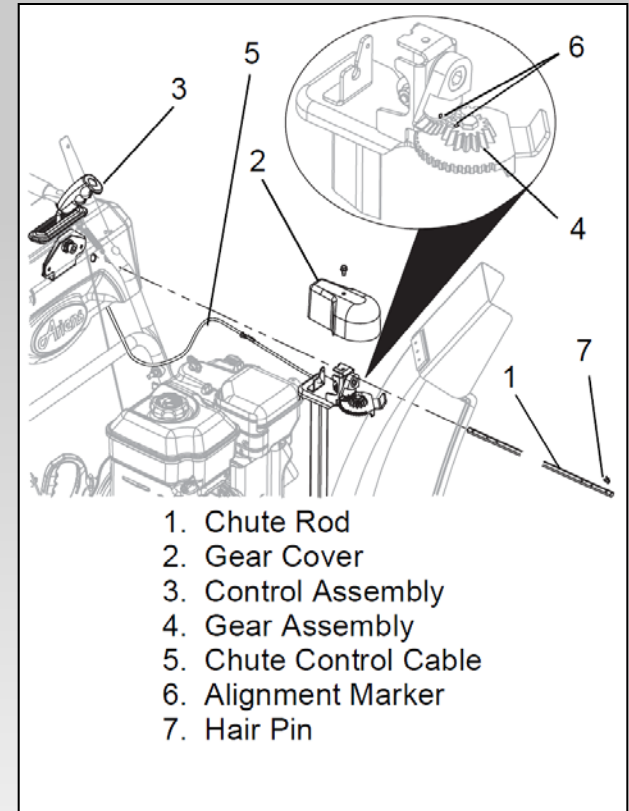



Step Three: Install Chute Control Assembly Cont.

3. Remove the rubber grommet from the control panel.
4. Make sure the chute control cable is routed between the lower handlebar and the bottom of the control panel, insert control assembly into slot in control panel from below and install assembly into nylon bushing in control panel.
5. Reinstall rubber grommet over control assembly knob and into control panel.

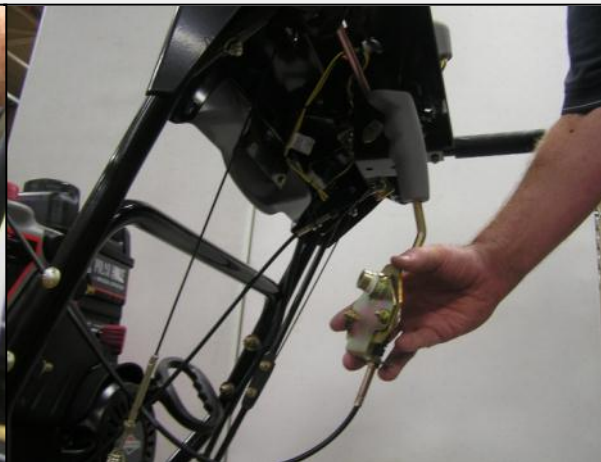
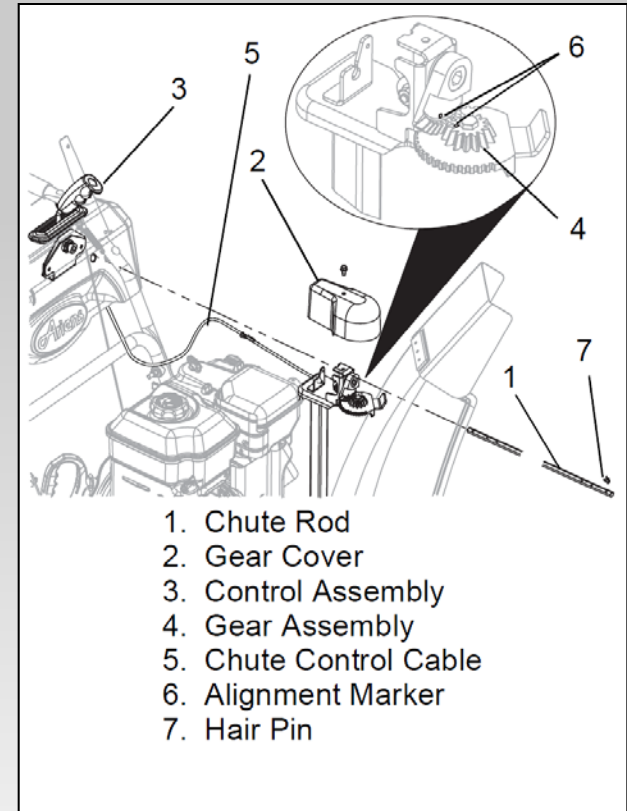



Step Four: Install Discharge Chute Rod

NOTE: To ensure the discharge chute follows its full range of travel, make sure the control lever is centered in the slot and pointing straight up before installing the chute rod.

1. Insert chute rod end without ears into control lever and slide into control panel until opposite end of rod clears the gear assembly.
2. Align end of chute rod with hex hole in gear assembly and insert until ears hit gear.
3. Insert hairpin into hole in chute rod near gear assembly.

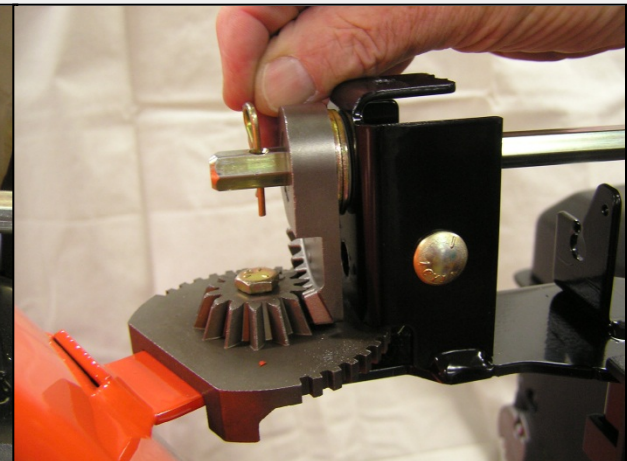
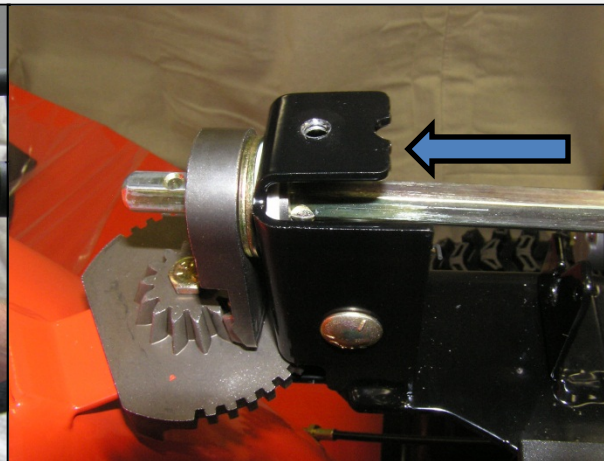
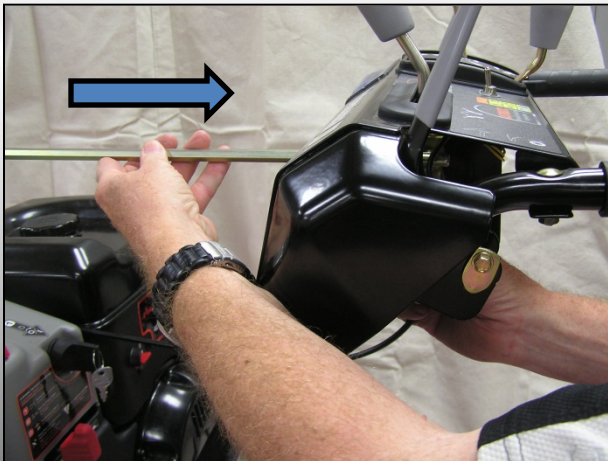
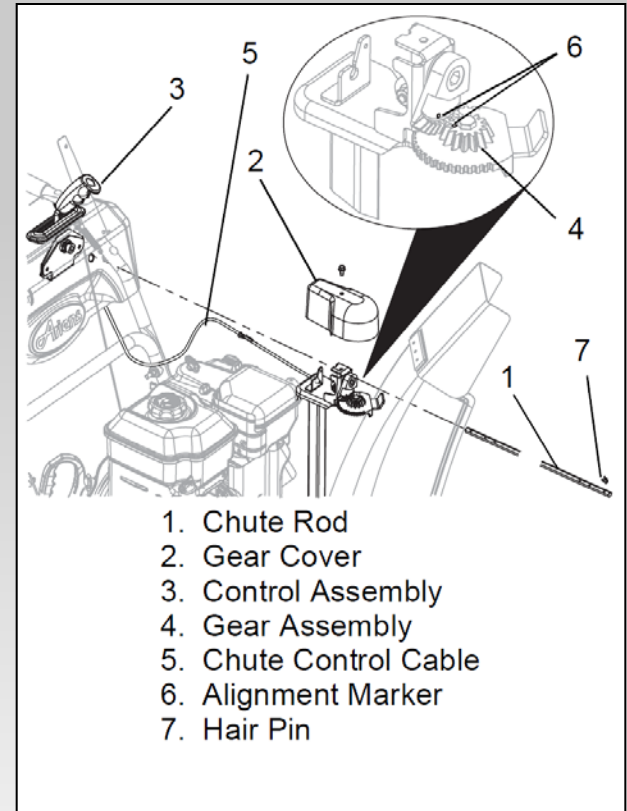



Step Four: Install Discharge Chute Rod Cont.

4. Hook the chute control cable onto the chute rod.

IMPORTANT: The chute control cable hook will prevent the cable from contacting the engine or muffler guard. Make sure the cable stays connected while unit is in operation.

5. Check to make sure the chute control cable ends are properly seated in control assembly and control arm.

6. Replace gear cover on top of chute pedestal.

7. Orient the chute and pedestal to its most vertical position and tighten pedestal hardware to 15-31 lbf-ft (20-42 N·m).

8. Make sure the discharge chute rotates left and right when you push the discharge chute control lever left and right.

NOTE: If chute does not stay in position, adjust as directed in *Discharge Chute Control* in Owner Manual.

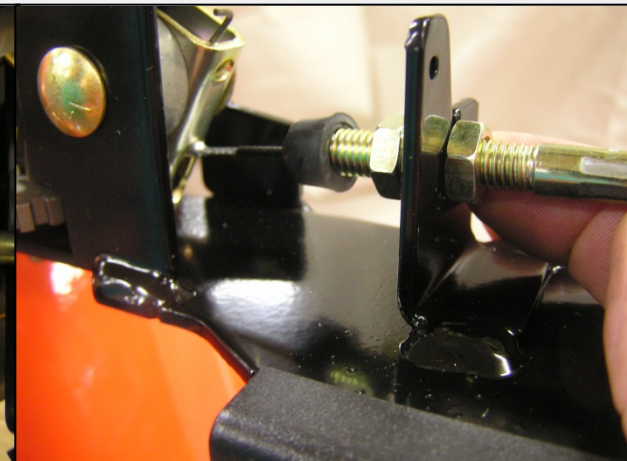
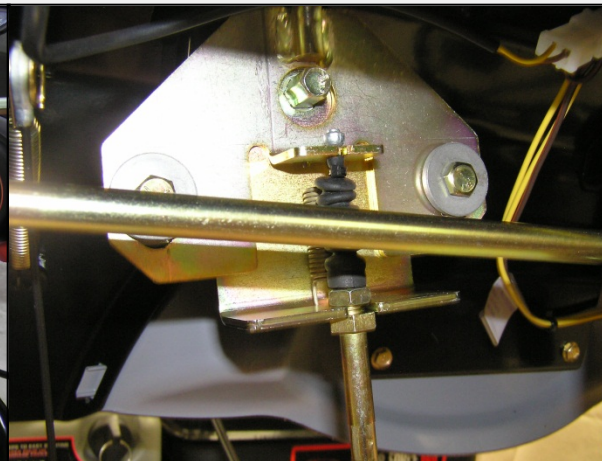
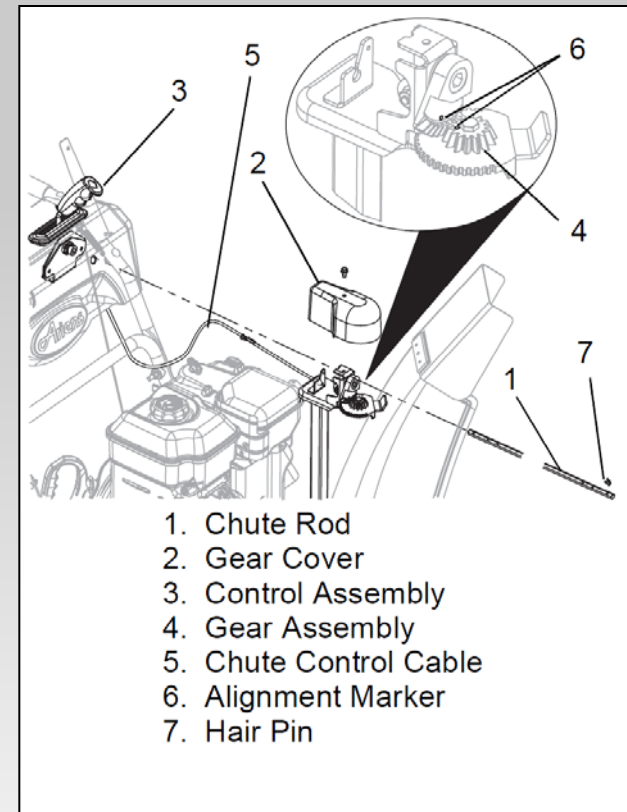



Step Five: Install Remote Deflector Control Cable

1. Connect the barrel cable end to the chute deflector cable anchor before clipping the cable to the discharge chute cable bracket.
2. Route deflector remote cable along the left side of the chute pedestal.
3. Insert the barrel on the cable end into the bracket on left side of chute deflector.
4. Hold seal out of the way while routing the cable through the bracket on the left side of the discharge chute, and then push the cable fitting into the bracket.
5. Push the seal securely over the end on the cable fitting to prevent water from entering the cable.
6. Check deflector travel. Adjust nut on cable end under handlebar to obtain full travel, if necessary (see *Remote Deflector Control* in Owners Manual).

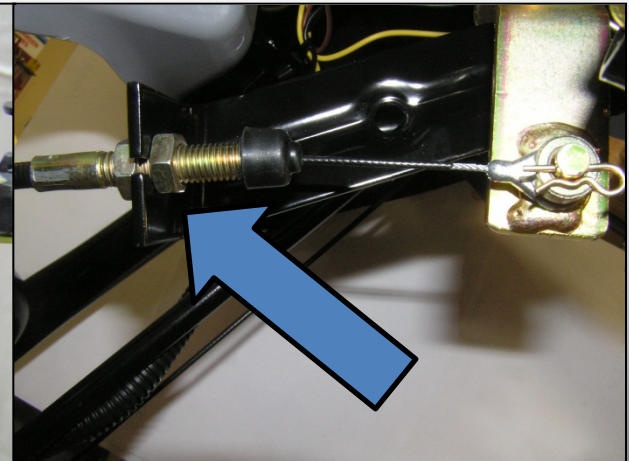
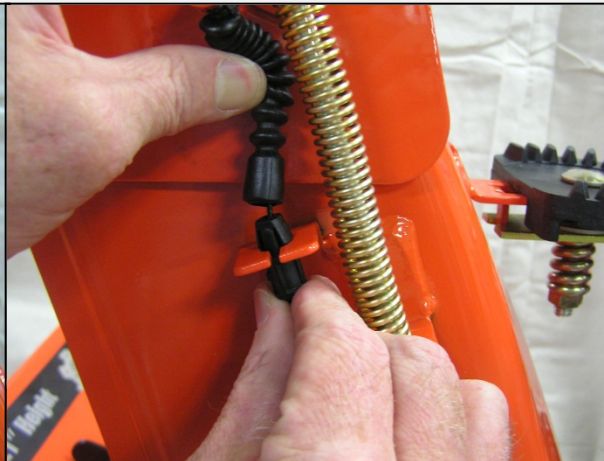
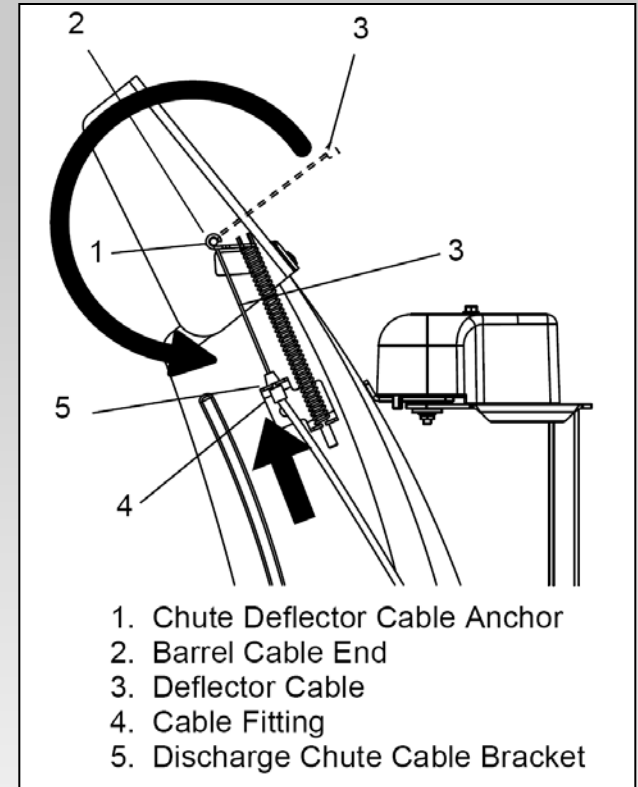



Step Six: Check Function of Dual Handle Interlock

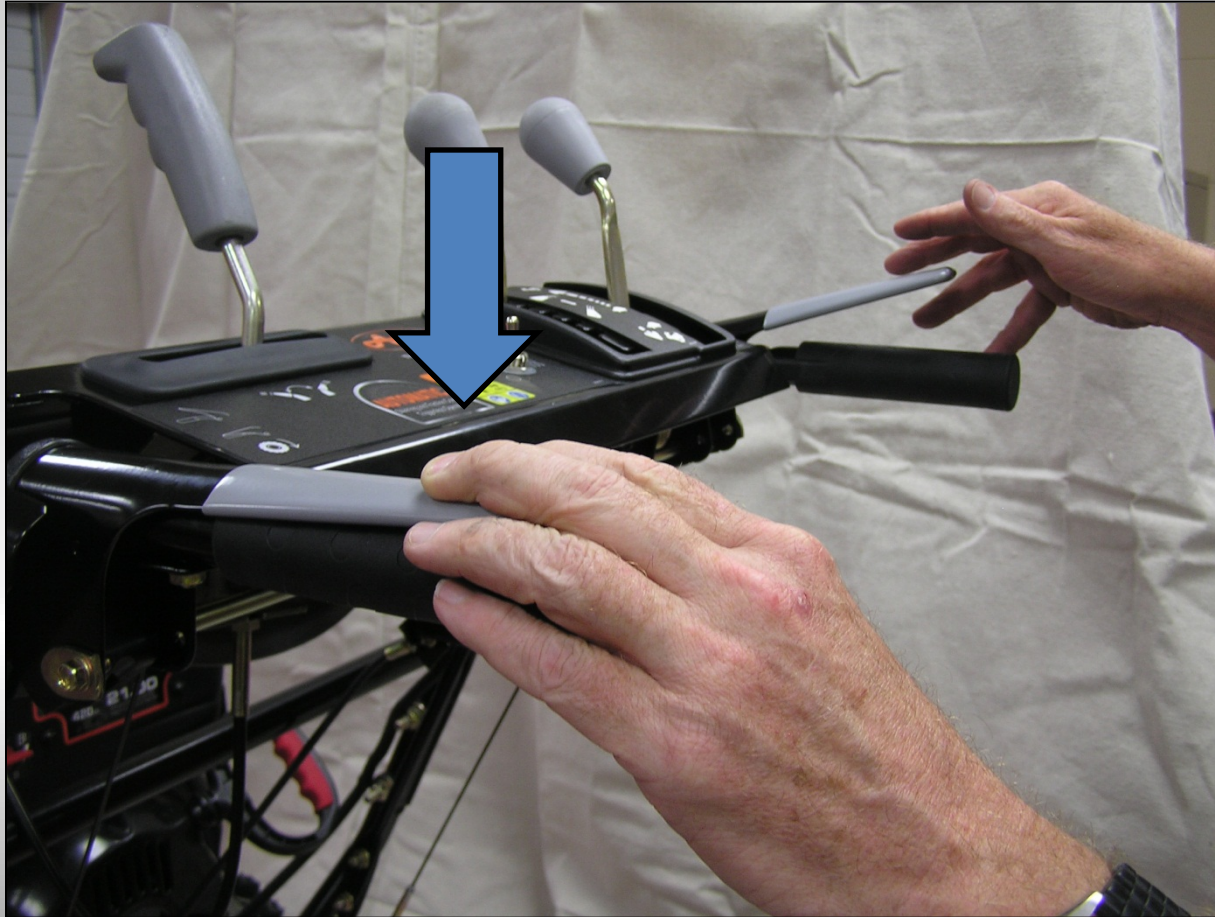

Without the engine running, press down (engage) both clutch levers. Release attachment clutch lever. Attachment clutch should remain engaged until traction clutch lever is released, then both clutches *must* disengage. If they do not, contact your dealer for repairs.



Step Seven: Check Tire Pressure



Check tire pressure and adjust to the pressure listed on tire sidewall.

Step Eight: Adjust Skid Shoes

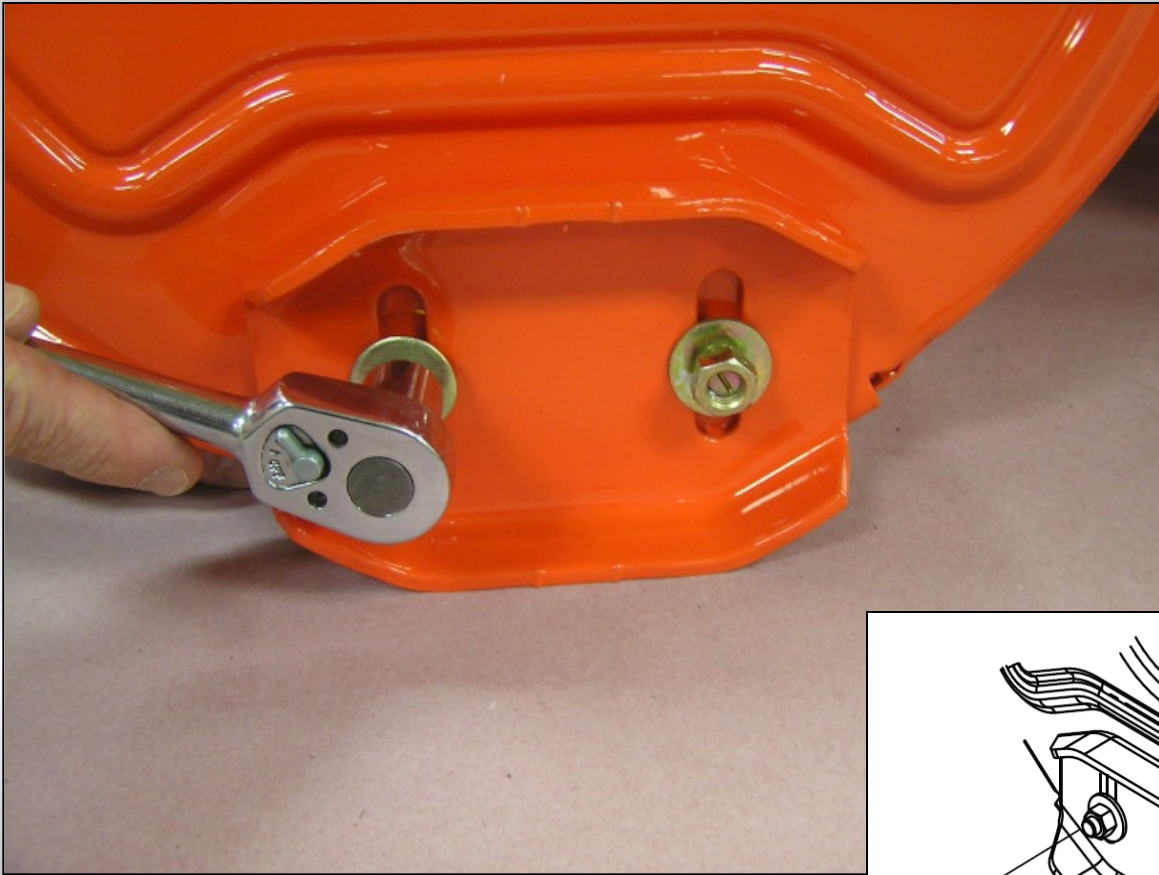

IMPORTANT: Skid shoes should be adjusted as conditions require. Allow 1/8 in. (3mm) between scraper blade and hard smooth surfaces. Allow 7/8 in. (22 mm) between scraper blade and uneven or gravel surfaces. (See Skid Shoes in Owners Manual).

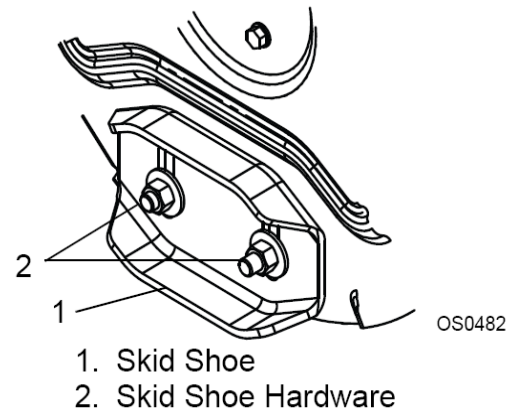



Step Nine: Check Auger Gearcase Oil

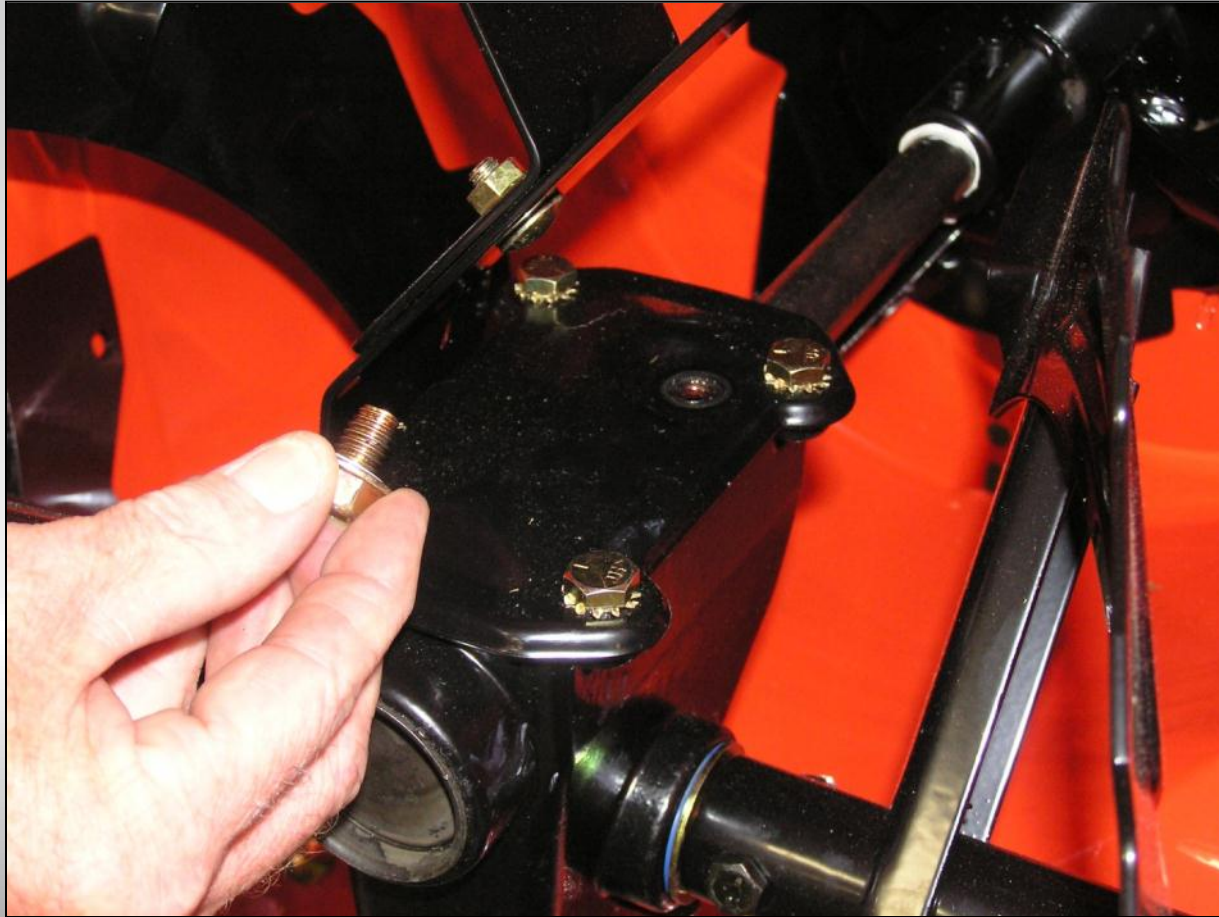

Check oil level in auger gearcase (see *Check Auger Gearcase* in Owners Manual).



Step Ten: Check Engine Crankcase Oil



IMPORTANT: The engine is shipped with oil in crankcase. Refer to Engine Manual for detailed instructions.



Step Eleven: Fill Engine Fuel Tank



Fill fuel tank. DO NOT OVERFILL! See *FILLING FUEL TANK* in Owners Manual.



Step Twelve: Starting the Engine





Starting Engine / Step A: Throttle

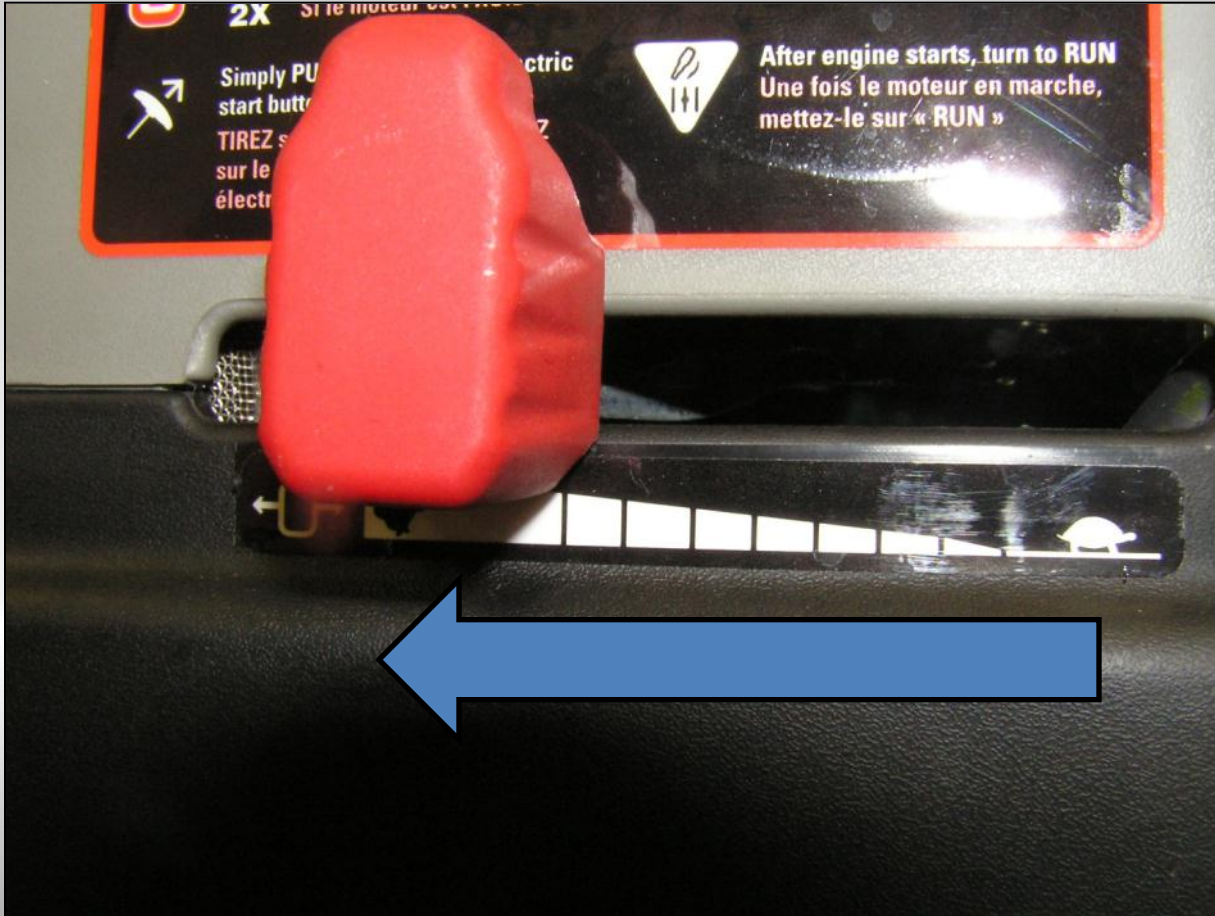

Move the throttle control lever to the fast position. Operate the engine with the throttle control lever in the fast position.



Starting Engine / Step B: Fuel Valve

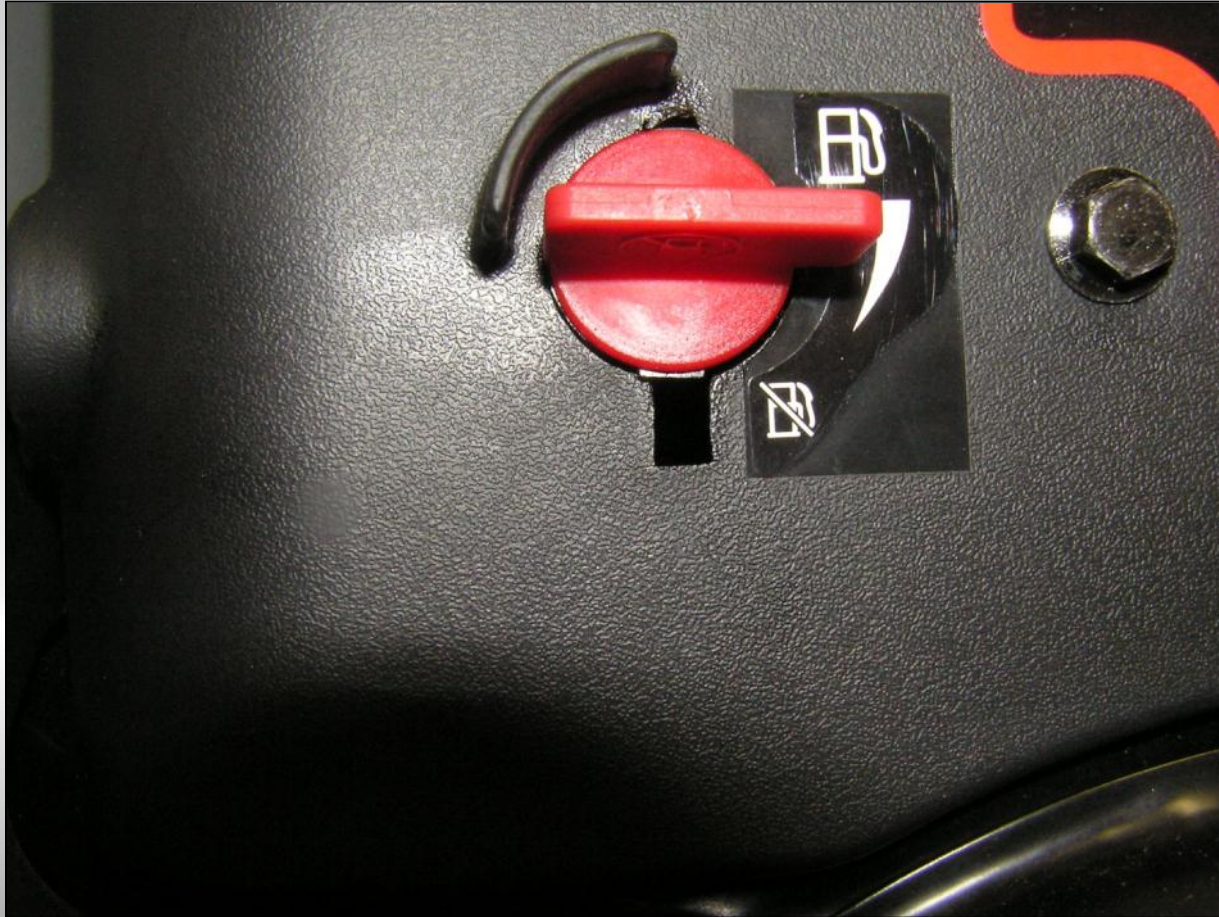

Turn the fuel shut-off valve to the ON position.



Starting Engine / Step C: Key



Insert the key and turn to the ON/START position.



Starting Engine / Step D: Choke



Turn the choke control knob to the choke position.

NOTE: Choke is usually unnecessary when restarting a warm engine.



Starting Engine / Step E: Prime

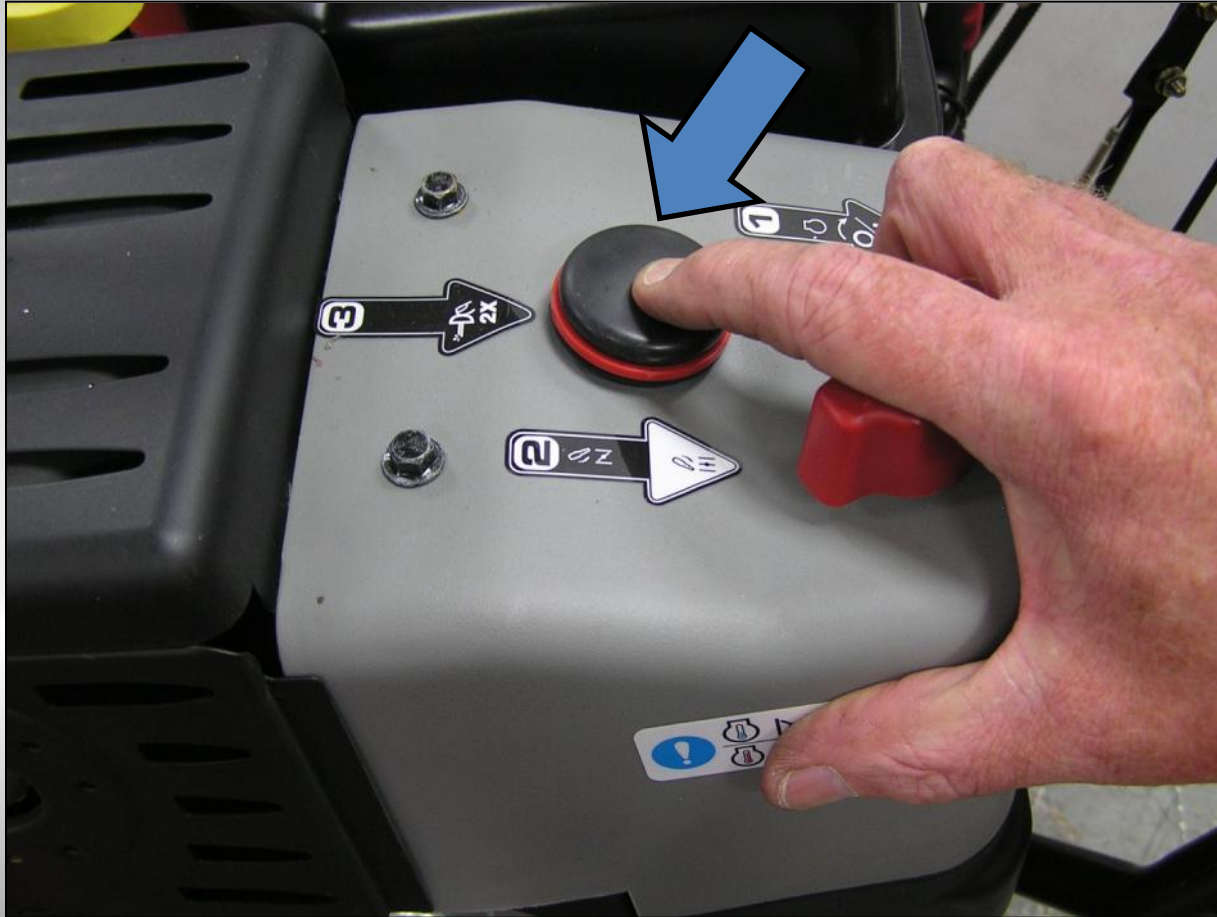

Push the primer two times. Be sure to cover vent hole on primer bulb.

NOTE: Priming is usually unnecessary when restarting a warm engine.



Starting Engine / Step F: (Manual Start)



Firmly hold the starter cord handle. Pull the starter cord handle slowly until resistance is felt, then pull rapidly.

NOTE: If the engine does not start after repeated attempts, go to BRIGGSandSTRATTON.COM or call **1-800-233-3723**.



Starting Engine / Step F: (Electric Start)



First connect the extension cord to the power cord receptacle and then into a wall receptacle. If an additional extension cord is required, make sure it is a 3-wire grounded extension cord.



Starting Engine / Step G: (Electric Start)



Depress the push button. After you start the engine, first disconnect the extension cord from the wall receptacle and then from the power cord receptacle.



Starting Engine / Step H: Warm up



Allow the engine to warm up for several minutes. Then, slowly move the choke control knob to the run position.



Step Thirteen: Stopping the Engine



Turn the key to the off position or move throttle control lever to slow and then to the stop position (completely right). Remove the key. Keep away from reach of children. After engine stops, turn the fuel shut-off valve to the closed (vertical) position.



Additional Resources

- Refer to Owners Manual and Engine Manual
- Contact Ariens Company
- For issues concerning engine, please contact Briggs and Stratton

www.ariens.com

Phone: 920-756-4688

E-mail: info@ariens.com

www.BRIGGSandSTRATTON.com

Phone: 800-233-3723