



# Quick Start Guide

## Deluxe 24 Platinum (921028 s/n 000101 & up)

- Step 1: Assemble Handlebars
- Step 2: Install Discharge Chute
- Step 3: Install Chute Control Assembly
- Step 4: Install Discharge Chute Rod
- Step 5: Install Remote Deflector Control
- Step 6: Check Function of Dual Handle Interlock
- Step 7: Check Tire Pressure
- Step 8: Adjust Skid Shoes
- Step 9: Check Auger Gearcase Oil
- Step 10: Check Engine Crankcase Oil
- Step 11: Fill Engine Fuel Tank
- Step 12: Start Engine
- Step 13: Stop Engine



READ AND UNDERSTAND ALL INSTRUCTION, WARNING, AND DANGER LABELS.

**IMPORTANT:** READ OPERATOR'S MANUAL AND ENGINE MANUAL THOROUGHLY AND FOLLOW THE IMPORTANT SAFE OPERATION PRACTICES BEFORE OPERATING.



# Step One: Assemble Handlebars

**NOTE: The Ariens company has made changes to packaging that affects this serial number range.**

**If the upper handlebars on your unit came already attached please disregard the following six slides.**

Not attached

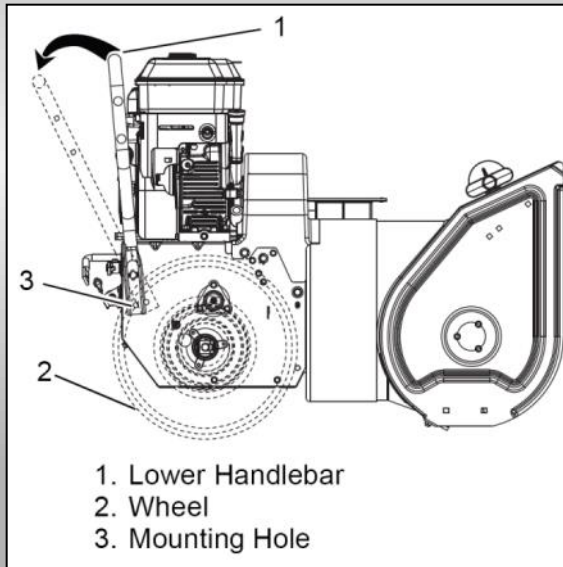

Attached

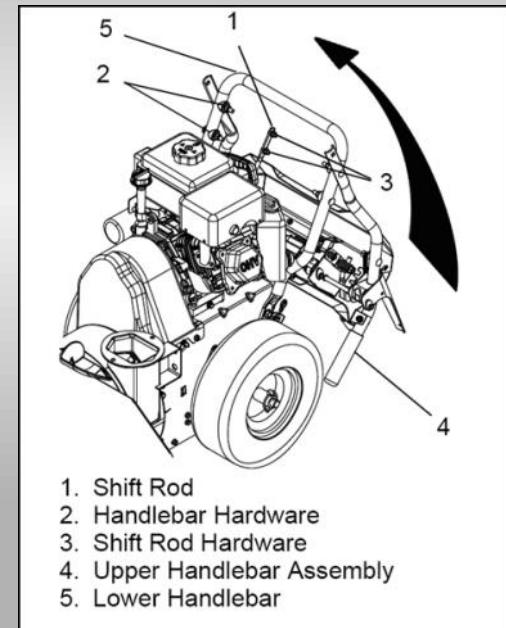



## Step One: Assemble Handlebars (Unfold Lower Handlebar)

**NOTE: This slide applies to  
UNATTACHED handlebars ONLY**

**IMPORTANT:** Be sure to block wheels or secure unit so it does not move during assembly.

1. Rotate lower handlebar out from unit so lower handlebar mounting holes align with mounting holes on the unit frame.
2. Secure lower handlebar to unit using two 3/8 in x 3/4 in. hex head serrated flange grade 5 bolts.
3. Tighten all four bolts to 25-42 lbf-ft (33,9-56,9 N·m)

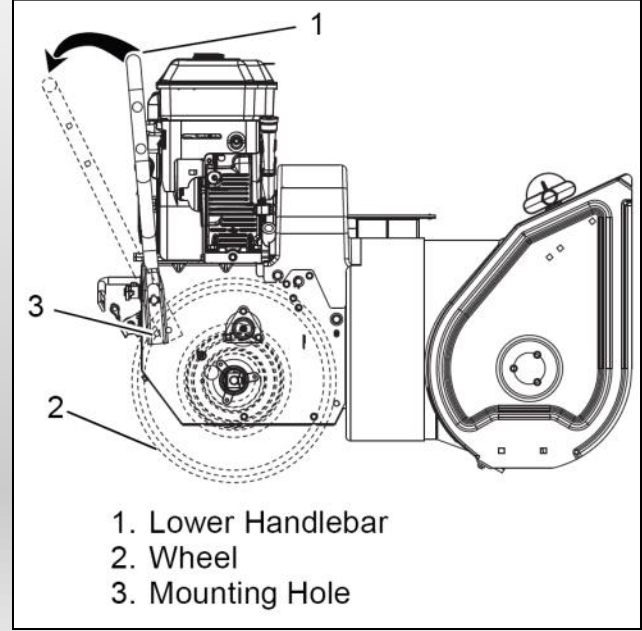



# Step One: Assemble Handlebars (Attach Upper Handlebar Assembly)

**NOTE: This slide applies to UNATTACHED handlebars ONLY**

1. Attach upper handlebar assembly to lower handlebar using two sets of the handlebar hardware. One set to attach each side of the handlebars.

**NOTE:** DO NOT tighten hardware. Allow upper handlebar assembly to hang from the lower handlebars for the next step.

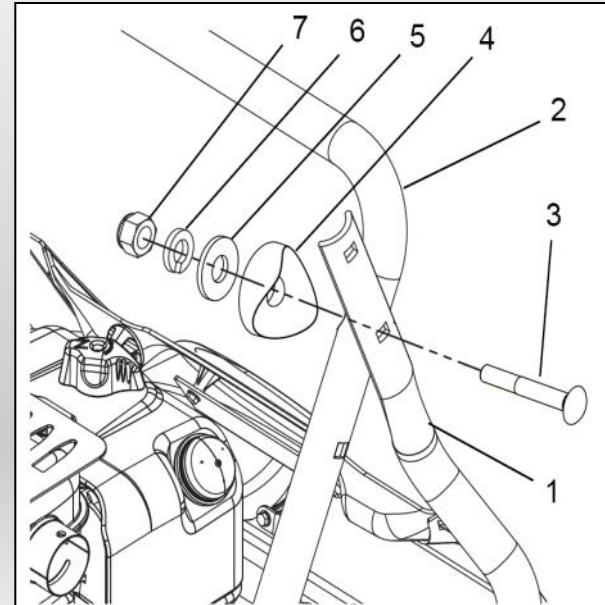

1. Upper Handlebar Assembly
2. Lower Handlebar
3. 5/16 in x 2-1/4 in. Round Head Square Neck Grade 5 Bolt
4. Handlebar Spacer
5. Flat Steel Washer
6. Locking Washer
7. 5/16 in Nyloc Nut





# Step One: Assemble Handlebars (Attach Control Cables)

**NOTE: This slide applies to  
UNATTACHED handlebars ONLY**

1. Hook spring end of attachment control cable to the clutch arm.
2. Hook spring end of the traction control cable to the cable eyelet on back of frame.

**NOTE:** Make sure the cable remains in the groove of the pulley.

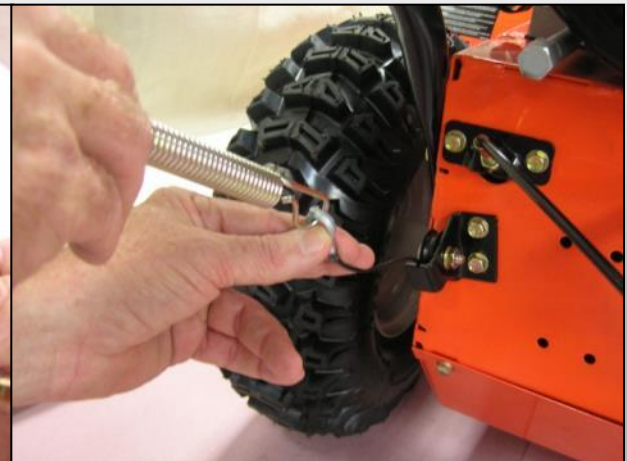
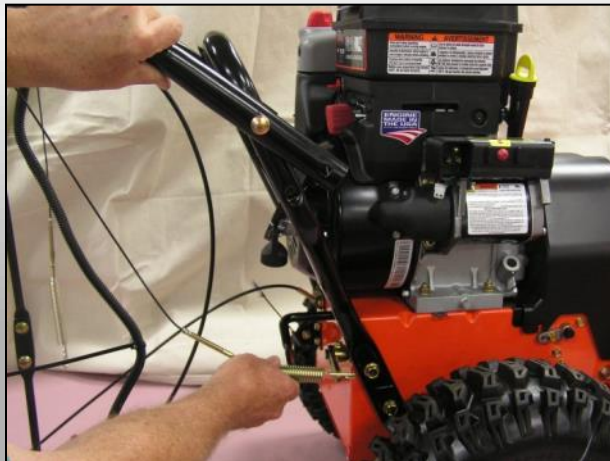
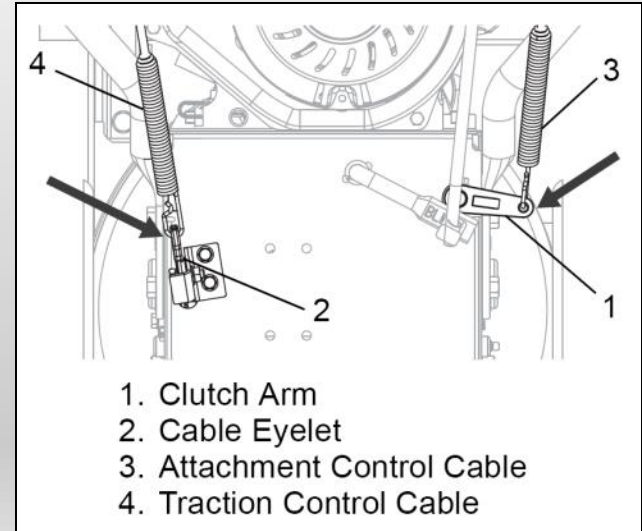



# Step One: Assemble Handlebars (Unfold Upper Handlebar)

1. Rotate handlebar into operating position.

**NOTE:** Be careful not to damage cable spring hooks when rotating handlebar upward.

2. Install the remaining handlebar hardware attaching the upper handlebar assembly to the lower handlebar.
3. Tighten all hardware.
4. Remove packaging around shift rod.
5. Rotate shift rod into place and tighten hardware.
6. Connect shift rod to speed selector arm and adjust as specified. See *Selector Adjustment* in the Owners Manual.
7. Adjust attachment cable as specified. See *Attachment Clutch/Brake Adjustment* in the Owners Manual.
8. Adjust the traction cable as specified. See *Traction Drive Clutch Adjustment* in the Owners Manual.

**NOTE: This slide applies to UNATTACHED handlebars ONLY**

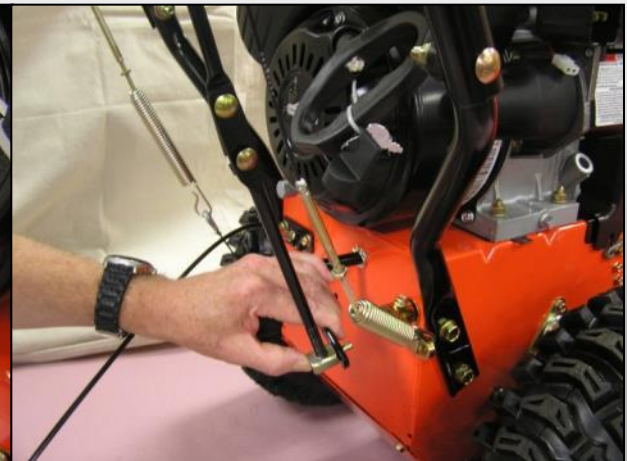
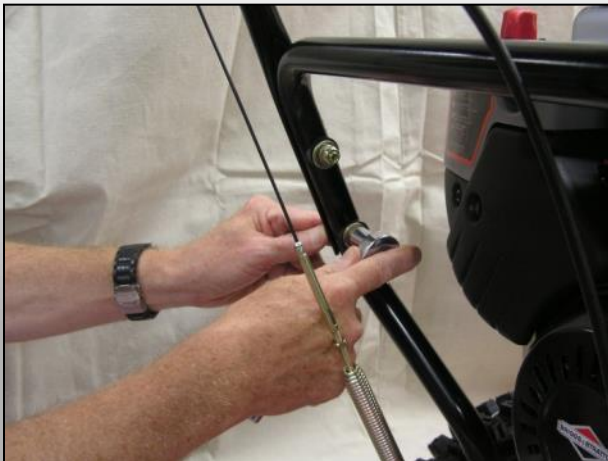
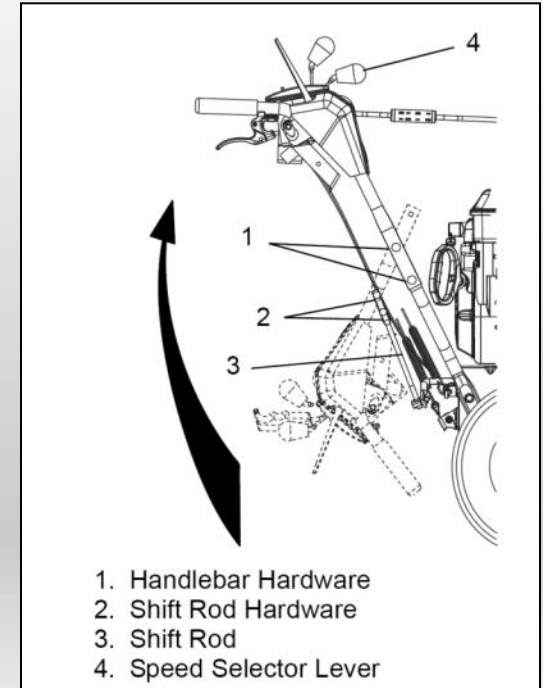



## Step One: Assemble Handlebars (Connect Headlight Wire Harness)

**NOTE: This slide applies to  
UNATTACHED handlebars ONLY**

**NOTE:** The headlight wire harness comes attached to the upper handlebar assembly.

1. Route the wire harness along the interior of the right side handlebar.
2. Connect to the engine electrical plug.
3. Press cable anchor into mounting hole in the frame near the engine electrical plug.
4. Secure the wire harness to the handlebars using the cable ties attached to the wire harness.

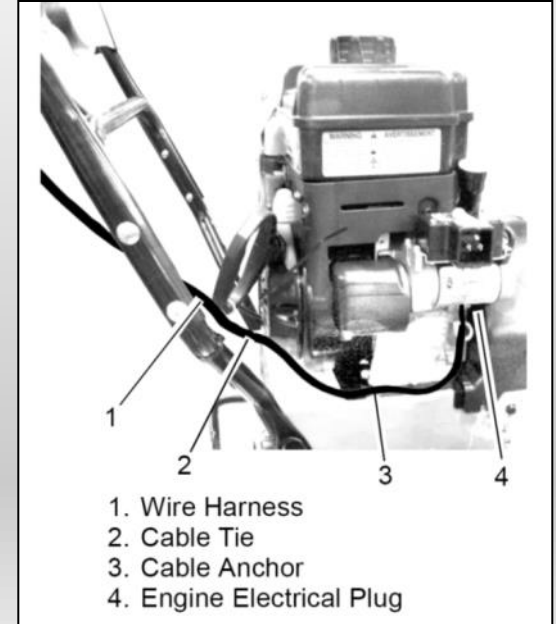



# Step One: Assemble Handlebar

1. Remove the lower and loosen the upper hardware on the handlebar assembly.
2. Loosen the hardware on the shift rod.
3. Put the speed selector lever in the sixth forward position.
4. Rotate the handlebar into operating position.

**NOTE:** Be careful not to damage cable spring hooks when rotating handlebar upward.

5. Install and tighten the hardware on the handlebar assembly and shift rod.

**NOTE: This slide applies to ATTACHED handlebars ONLY**

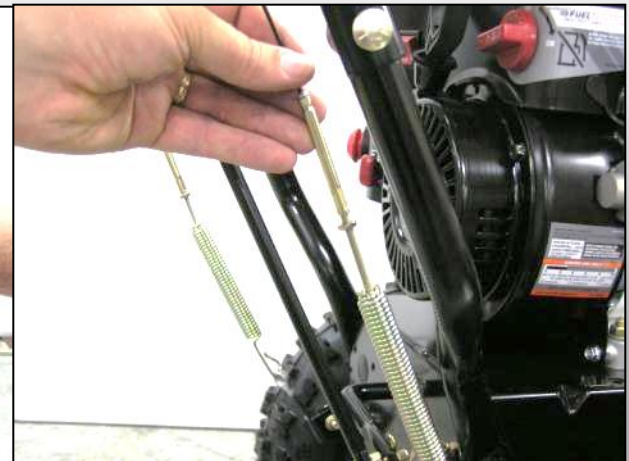
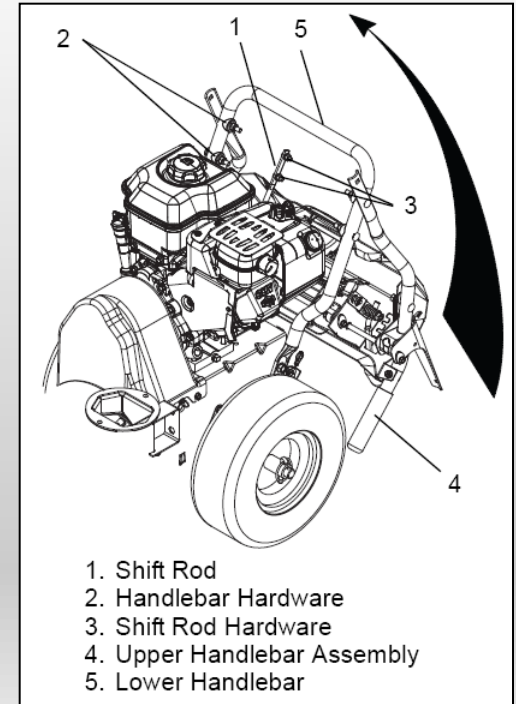





## Step Two: Install Discharge Chute

1. Grease underside of discharge chute ring (if not already greased).
2. Remove mounting hardware from auger housing.
3. Install discharge chute over opening in the auger housing. Finger tighten the mounting hardware removed above.

**NOTE:** Leave discharge chute pedestal loose to help install the chute crank.

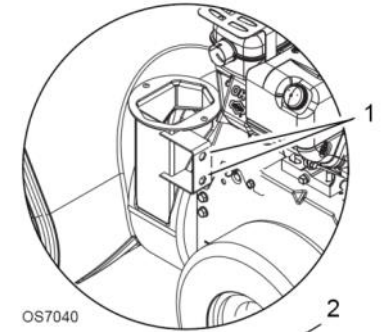

OS7040

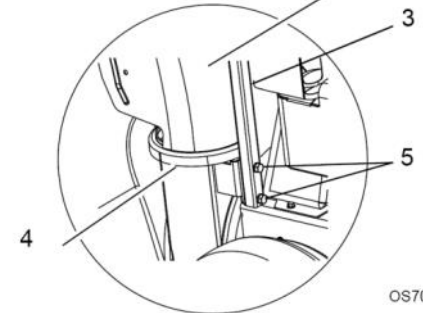

OS7045

1. Mounting Holes
2. Discharge Chute
3. Chute Pedestal
4. Discharge Chute Ring
5. Mounting Hardware

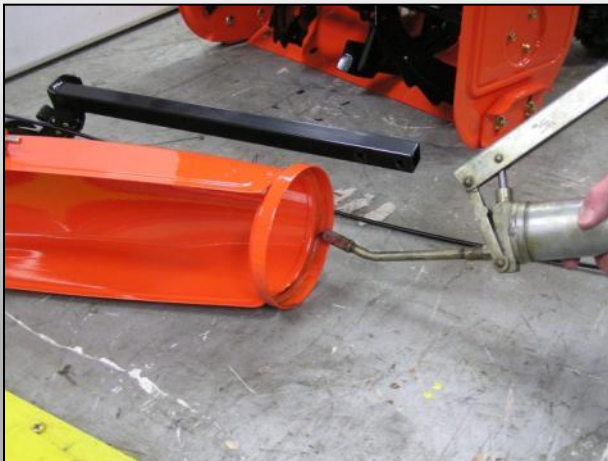



## Step Three: Install Chute Control Assembly

1. Remove the gear cover from top of chute pedestal.
2. Release the lock teeth on the gear assembly with your finger and rotate the discharge chute so it points straight ahead.

**NOTE:** Make sure alignment markers are lined up when discharge chute is pointing straight ahead.

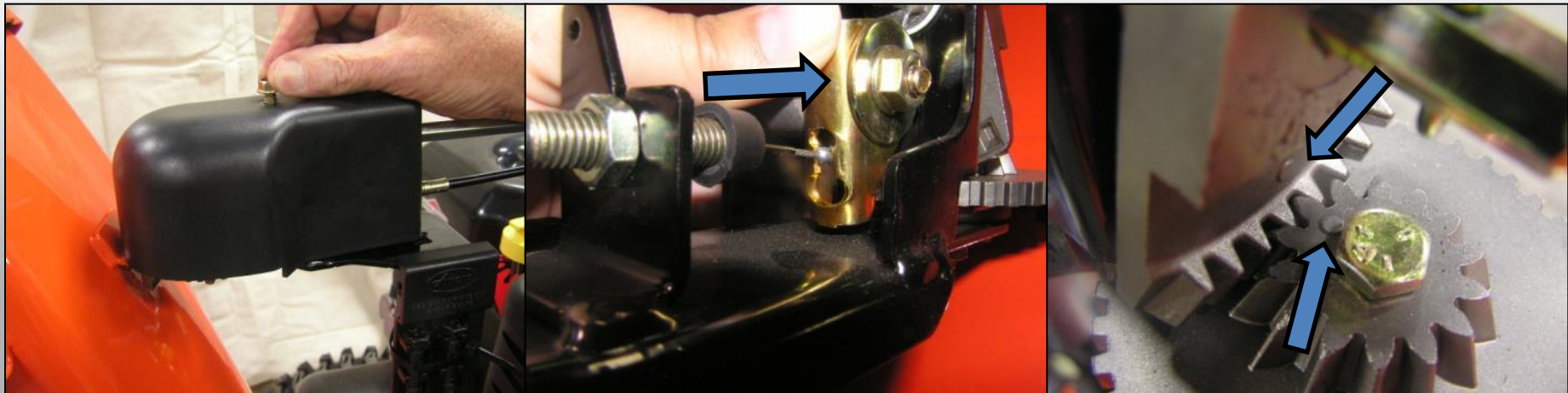
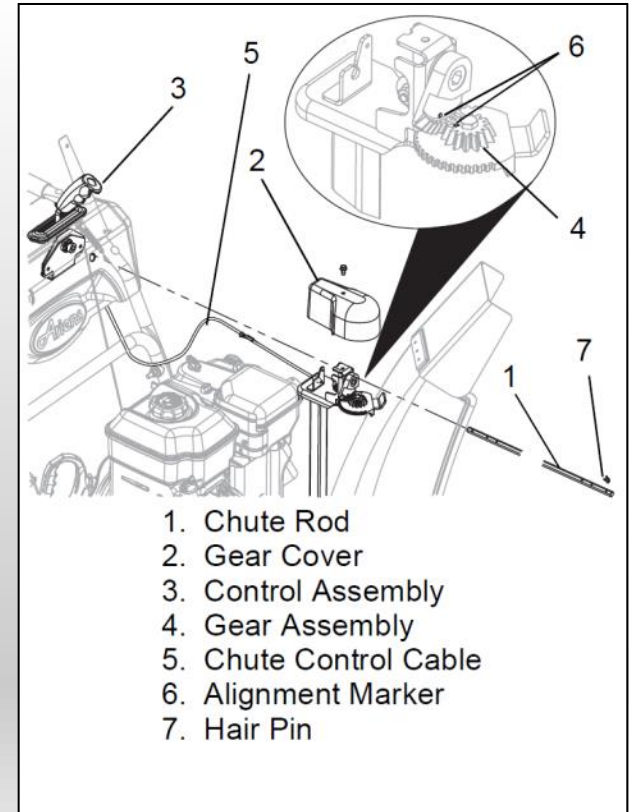



## Step Three: Install Chute Control Assembly Cont.

3. Remove the rubber grommet from the control panel.
4. Make sure the chute control cable is routed between the lower handlebar and the bottom of the control panel, insert control assembly into slot in control panel from below and install assembly into nylon bushing in control panel.
5. Reinstall rubber grommet over control assembly knob and into control panel.

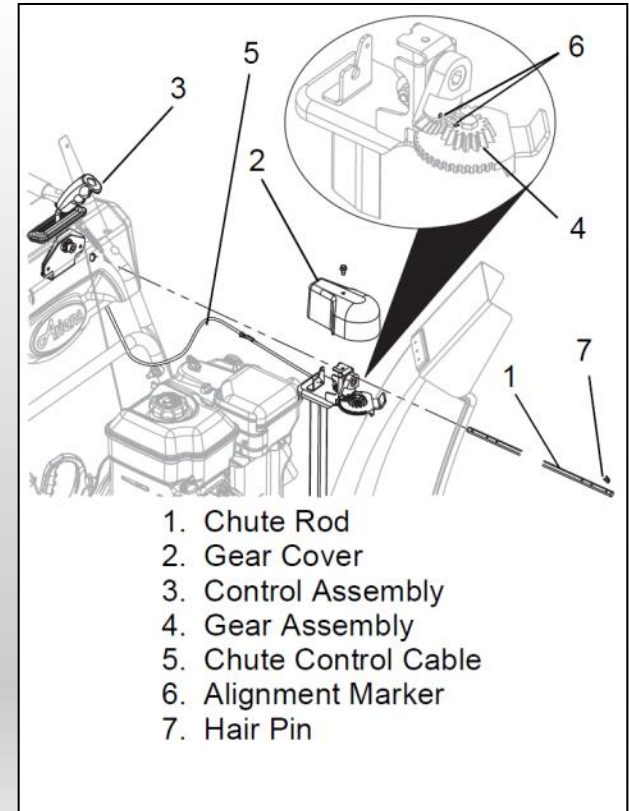



## Step Four: Install Discharge Chute Rod

**NOTE:** To ensure the discharge chute follows its full range of travel, make sure the control lever is centered in the slot and pointing straight up before installing the chute rod.

1. Insert chute rod end without ears into control lever and slide into control panel until opposite end of rod clears the gear assembly.
2. Align end of chute rod with hex hole in gear assembly and insert until ears hit gear.
3. Insert hairpin into hole in chute rod near gear assembly.

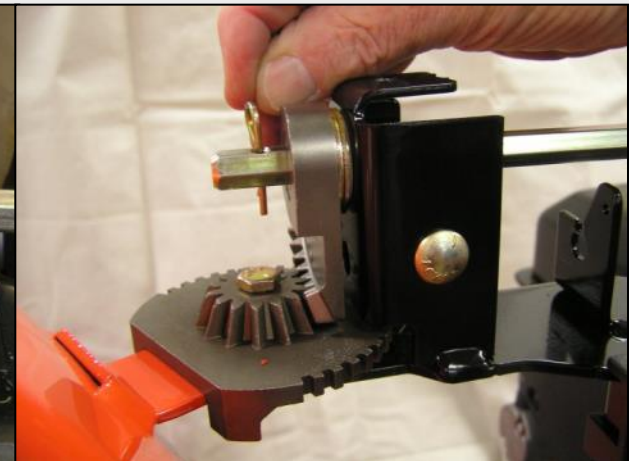
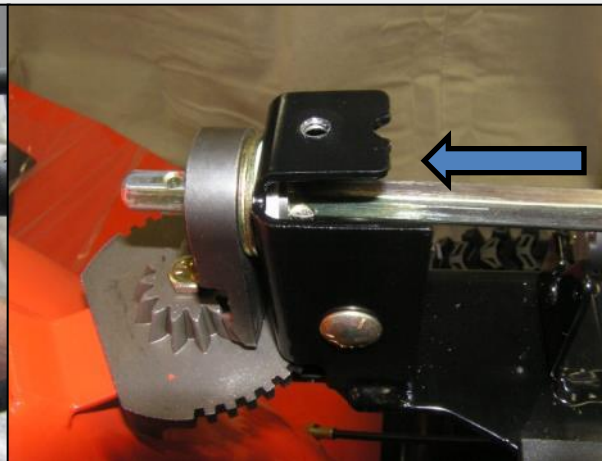
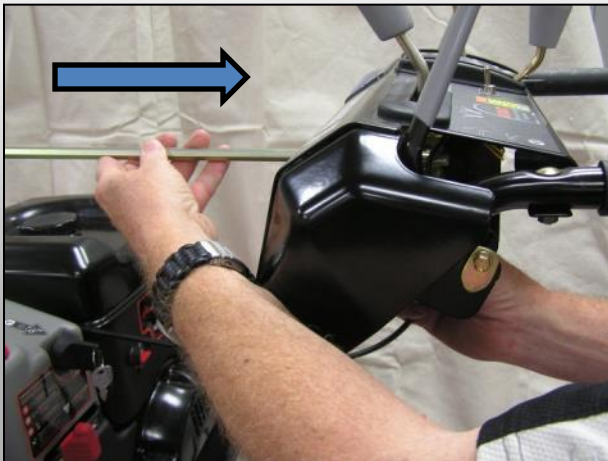
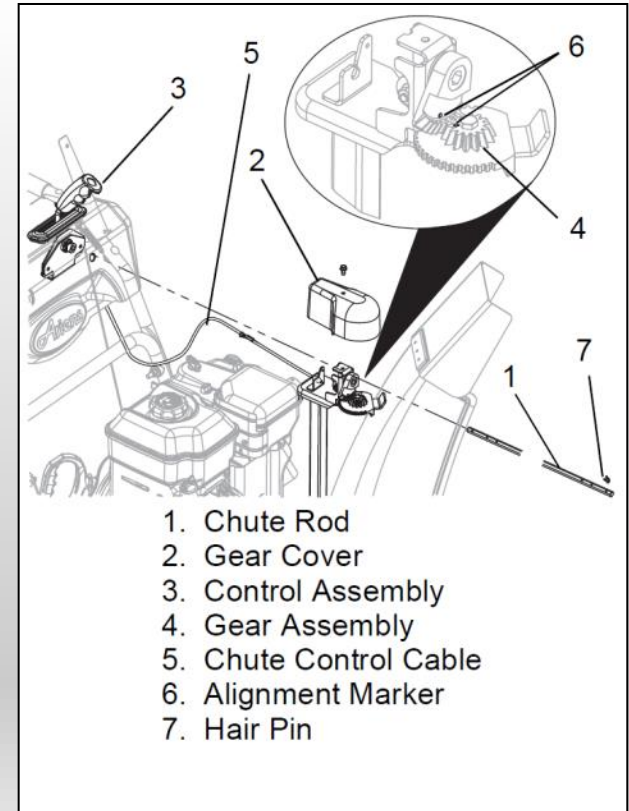



## Step Four: Install Discharge Chute Rod Cont.

4. Hook the chute control cable onto the chute rod.

**IMPORTANT:** The chute control cable hook will prevent the cable from contacting the engine or muffler guard. Make sure the cable stays connected while unit is in operation.

5. Check to make sure the chute control cable ends are properly seated in control assembly and control arm.

6. Replace gear cover on top of chute pedestal.

7. Orient the chute and pedestal to its most vertical position and tighten pedestal hardware to 15-31 lbf-ft (20-42 N·m).

8. Make sure the discharge chute rotates left and right when you push the discharge chute control lever left and right.

**NOTE:** If chute does not stay in position, adjust as directed in *Discharge Chute Control* in Owner Manual.

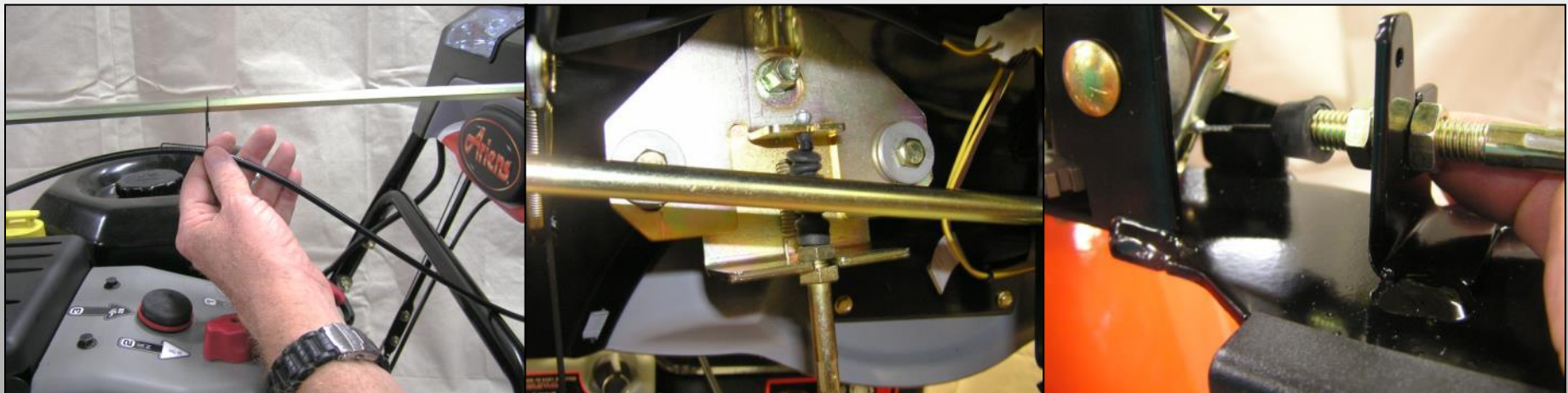
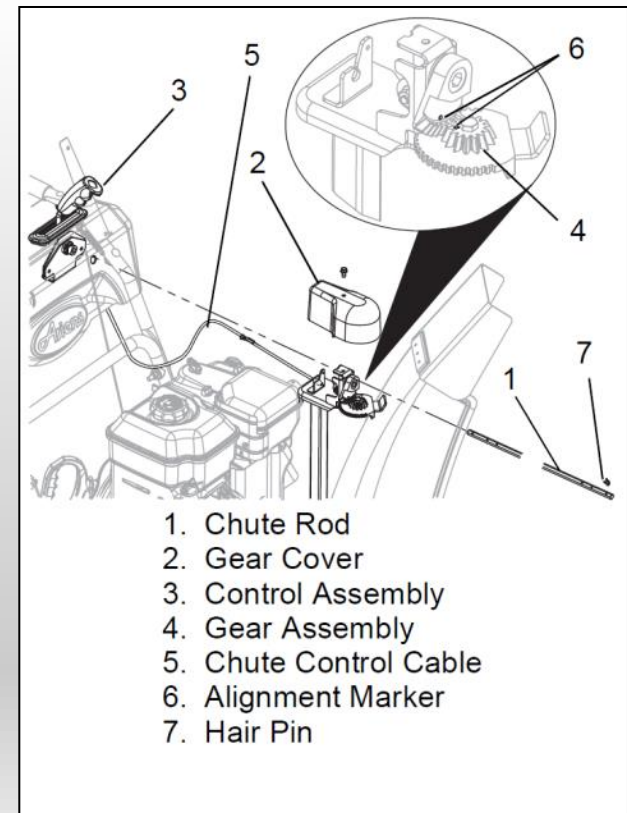



## Step Five: Install Remote Deflector Control Cable

1. Connect the barrel cable end to the chute deflector cable anchor before clipping the cable to the discharge chute cable bracket.
2. Route deflector remote cable along the left side of the chute pedestal.
3. Insert the barrel on the cable end into the bracket on left side of chute deflector.
4. Hold seal out of the way while routing the cable through the bracket on the left side of the discharge chute, and then push the cable fitting into the bracket.
5. Push the seal securely over the end on the cable fitting to prevent water from entering the cable.
6. Check deflector travel. Adjust nut on cable end under handlebar to obtain full travel, if necessary see *Remote Deflector Control* in Owners Manual.

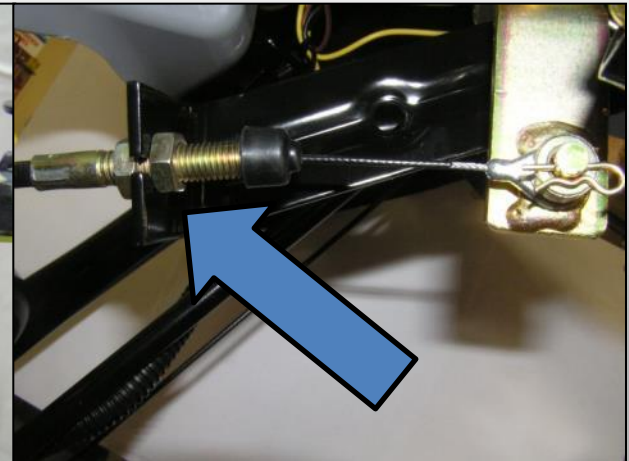
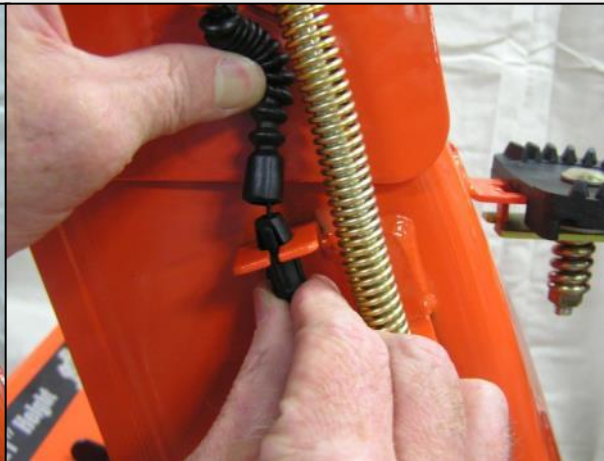
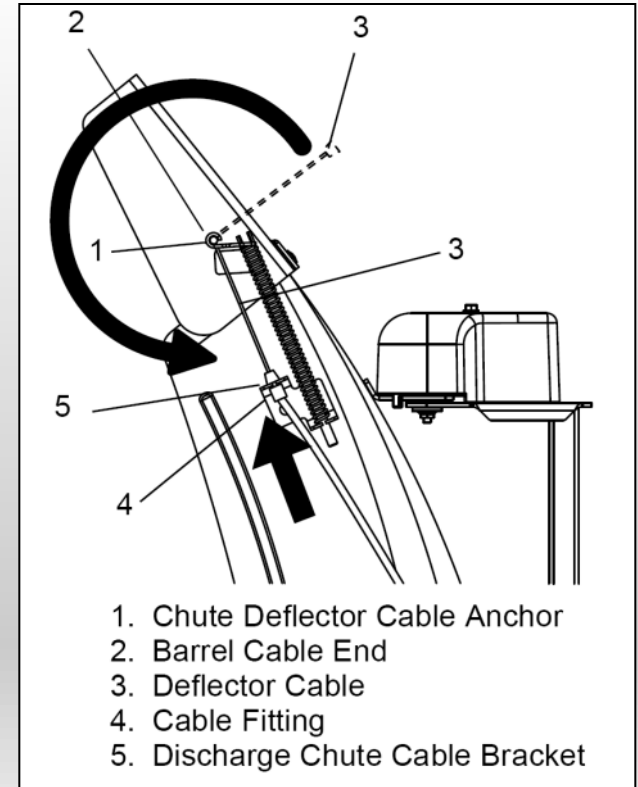



## Step Six: Check Function of Dual Handle Interlock

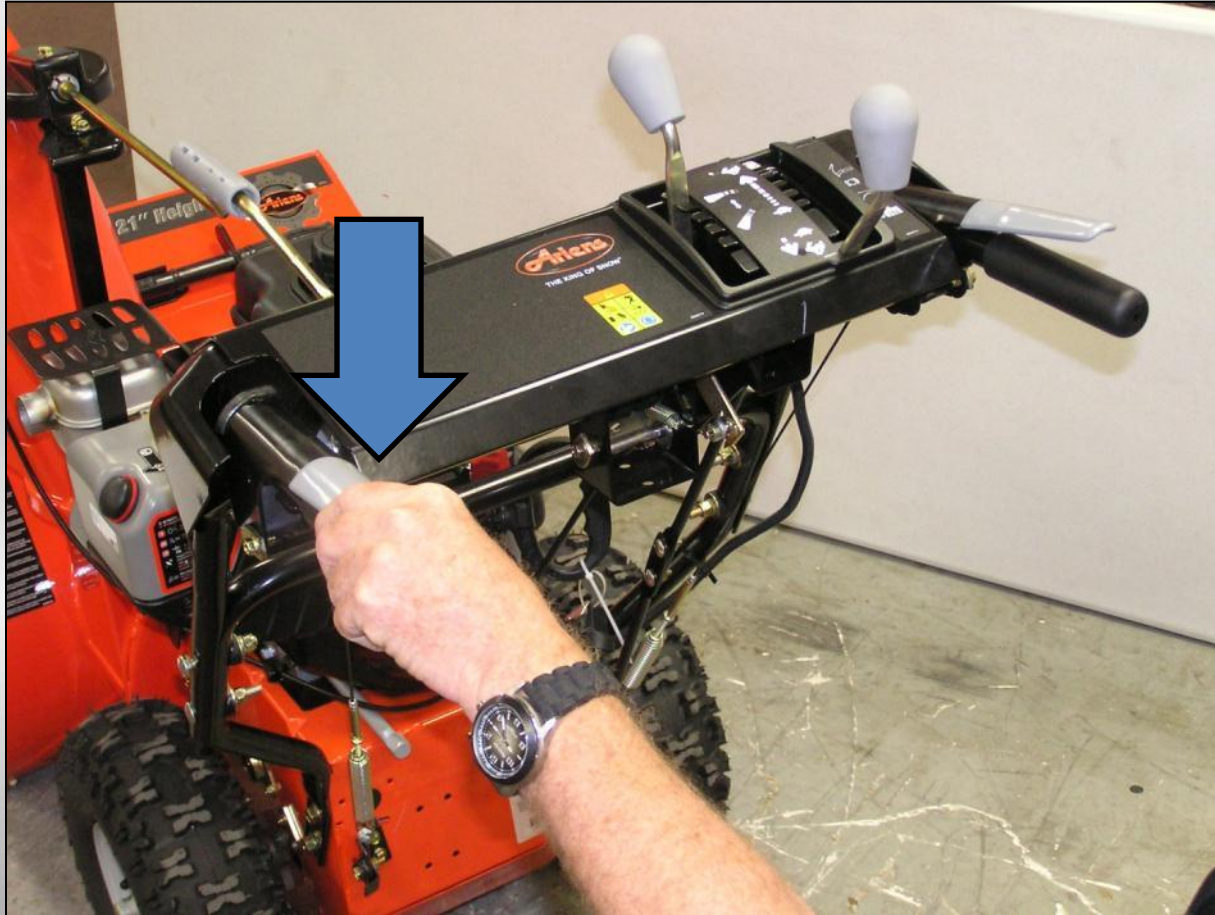

Without the engine running, press down (engage) both clutch levers. Release attachment clutch lever. Attachment clutch should remain engaged until traction clutch lever is released, then both clutches *must* disengage. If they do not, contact your dealer for repairs.

## Step Seven: Check Tire Pressure



Check tire pressure and adjust to the pressure listed on tire sidewall.



## Step Eight: Adjust Skid Shoes

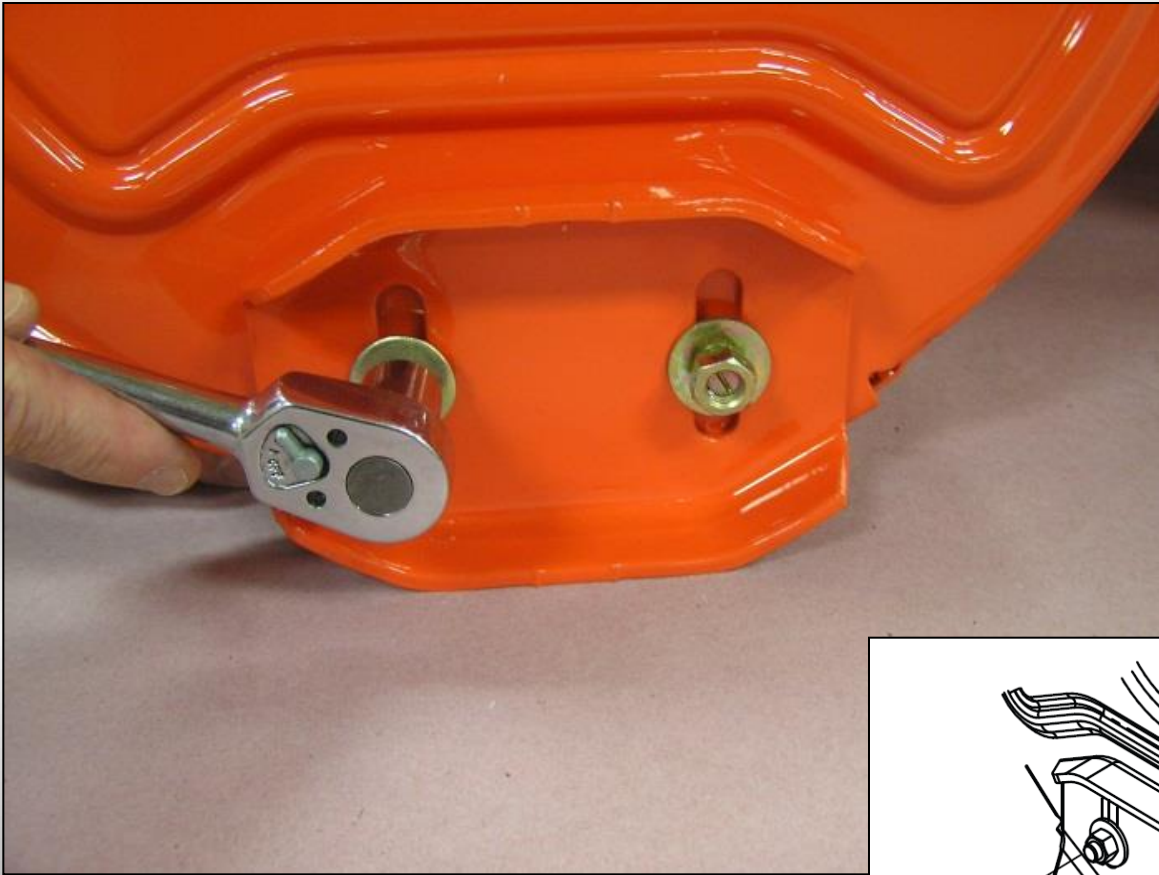

**IMPORTANT:** Skid shoes should be adjusted as conditions require. Allow 1/8 in. (3mm) between scraper blade and hard smooth surfaces. Allow 7/8 in (22 mm) between scraper blade and uneven or gravel surfaces. (See Skid Shoes in Owners Manual).

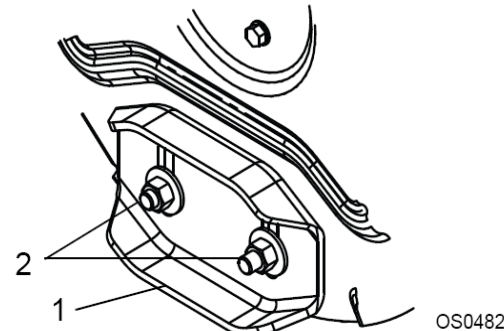

1. Skid Shoe
2. Skid Shoe Hardware

## Step Nine: Check Auger Gearcase Oil

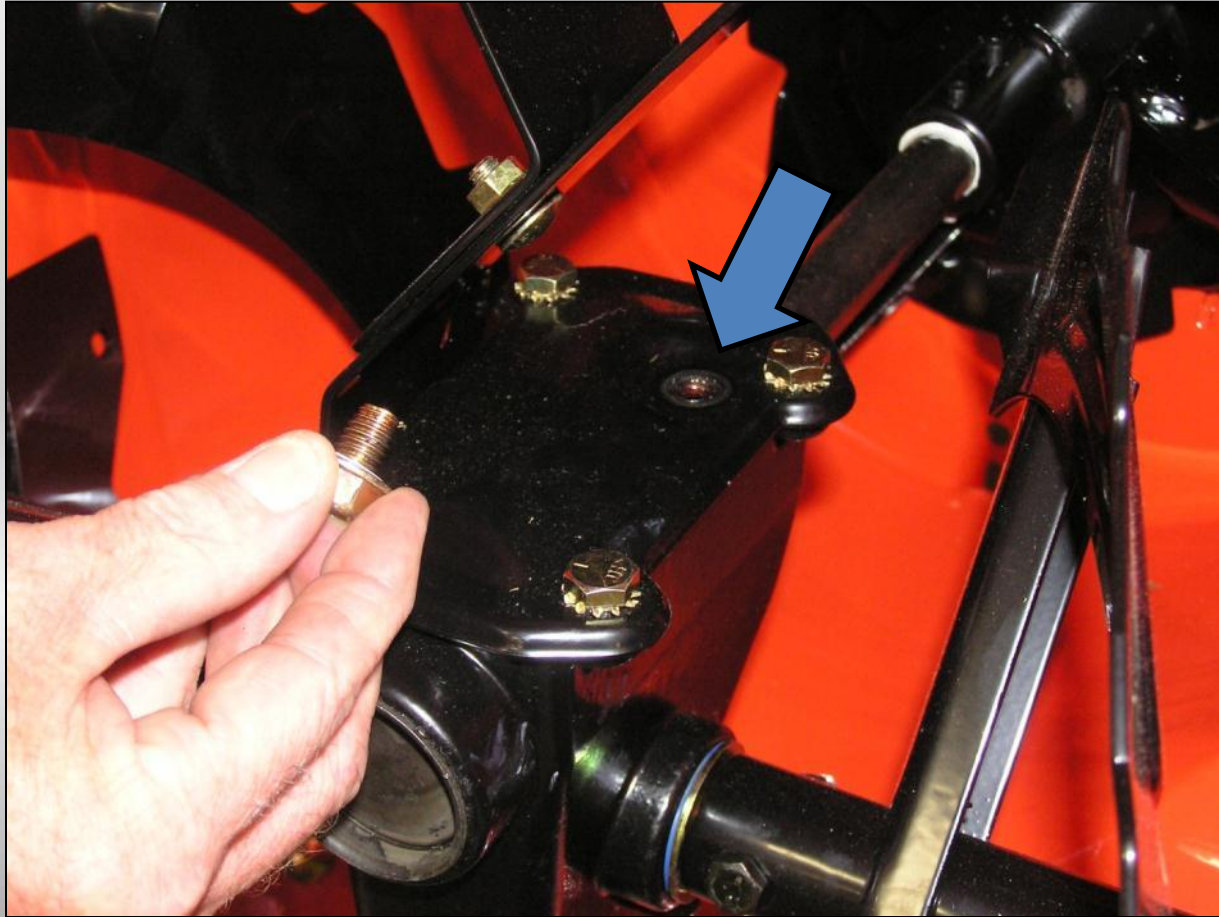

Check oil level in auger gearcase (see *Check Auger Gearcase* in Owners Manual).



## Step Ten: Check Engine Crankcase Oil (Ariens AX)



**IMPORTANT:** The engine is shipped with 5W-30 oil in crankcase. Refer to engine manual for detailed instructions.



## Step Eleven: Fill Engine Fuel Tank (Ariens AX)



Fill fuel tank. DO NOT OVERFILL! See *FILLING FUEL TANK* in Owners Manual.



# Step Twelve: Starting the Engine (Ariens AX)





# Starting Engine / Step A: Choke



Turn throttle all the way up. Turn choke ON.



## Starting Engine / Step B: Rocker Switch

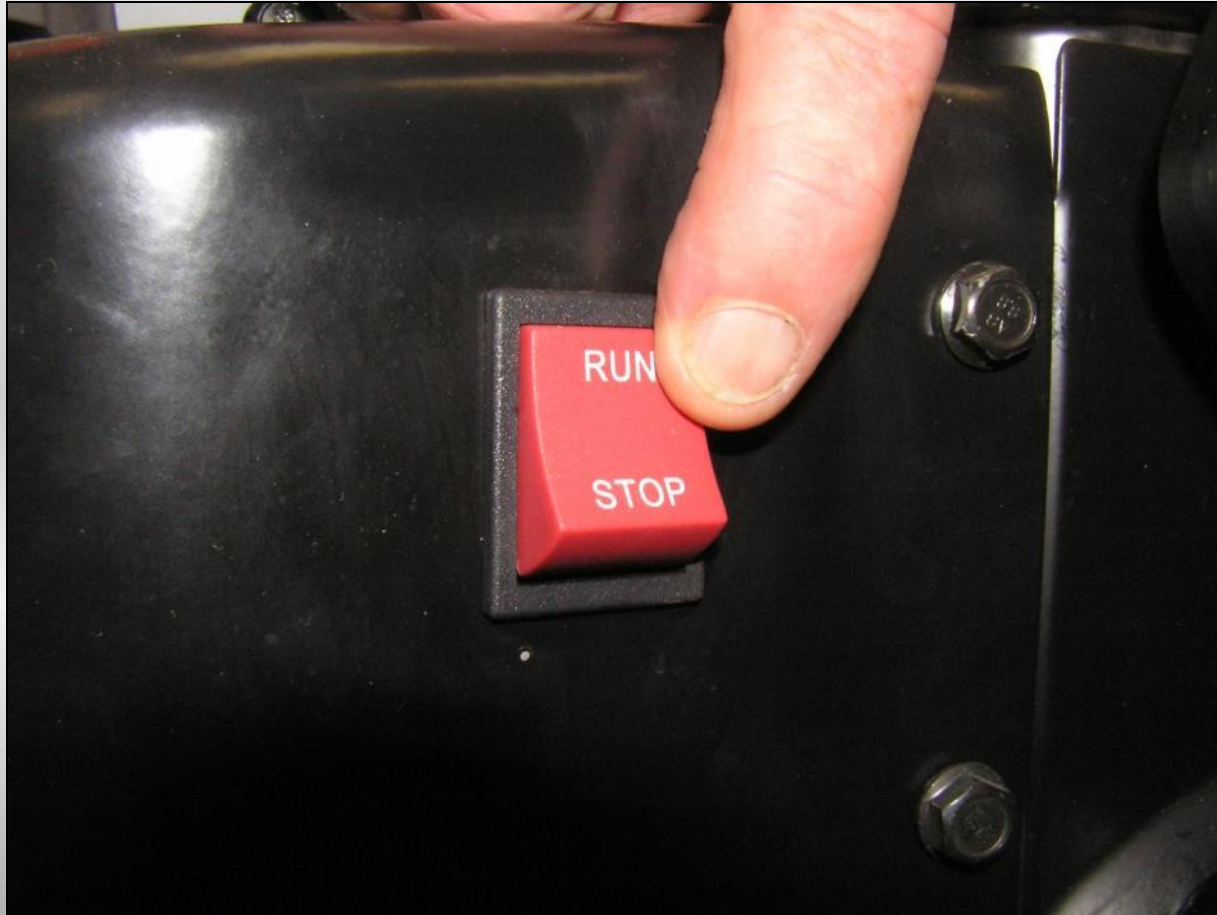

Push rocker switch  
to RUN position.



## Starting Engine / Step C: Fuel Shut Off Valve

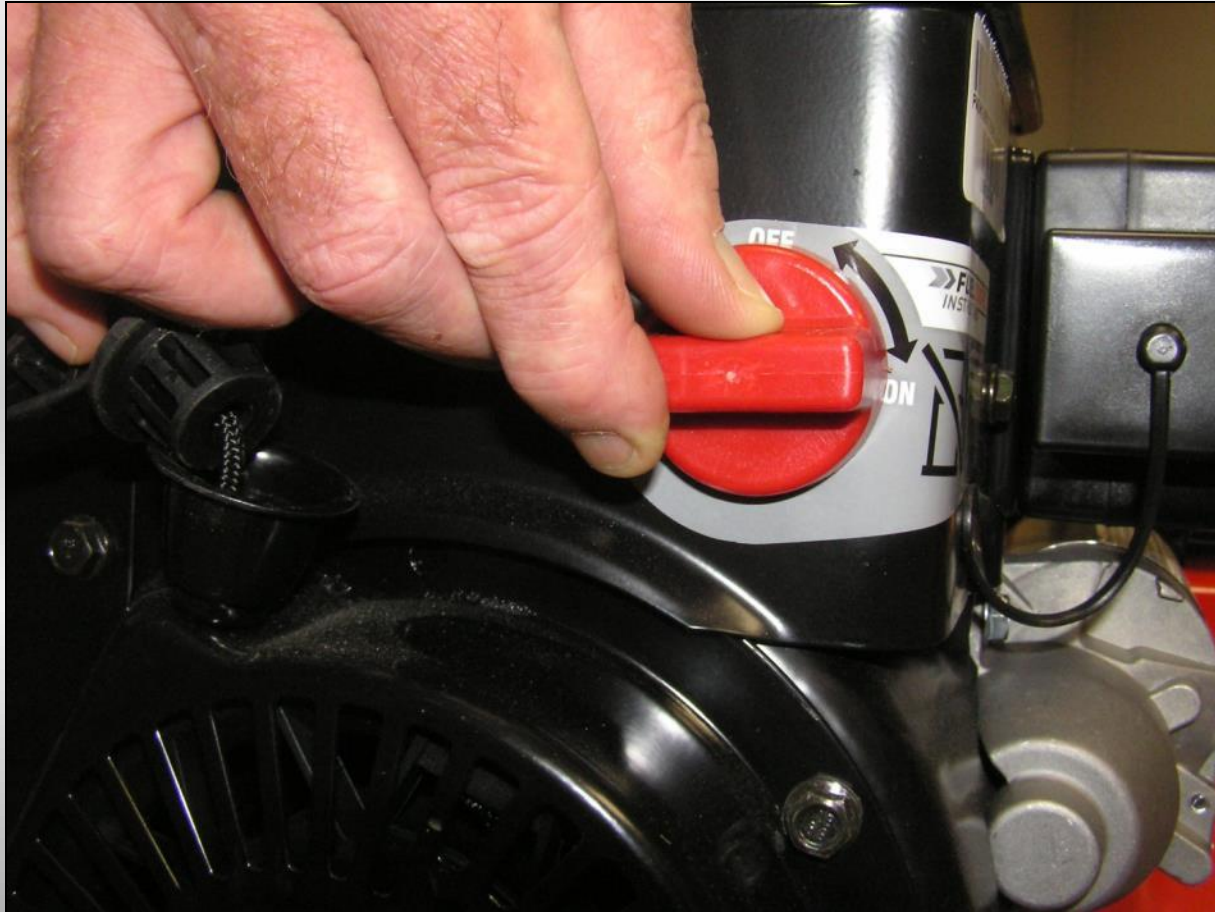

Turn fuel petcock  
to ON position.





## Starting Engine / Step D: Key

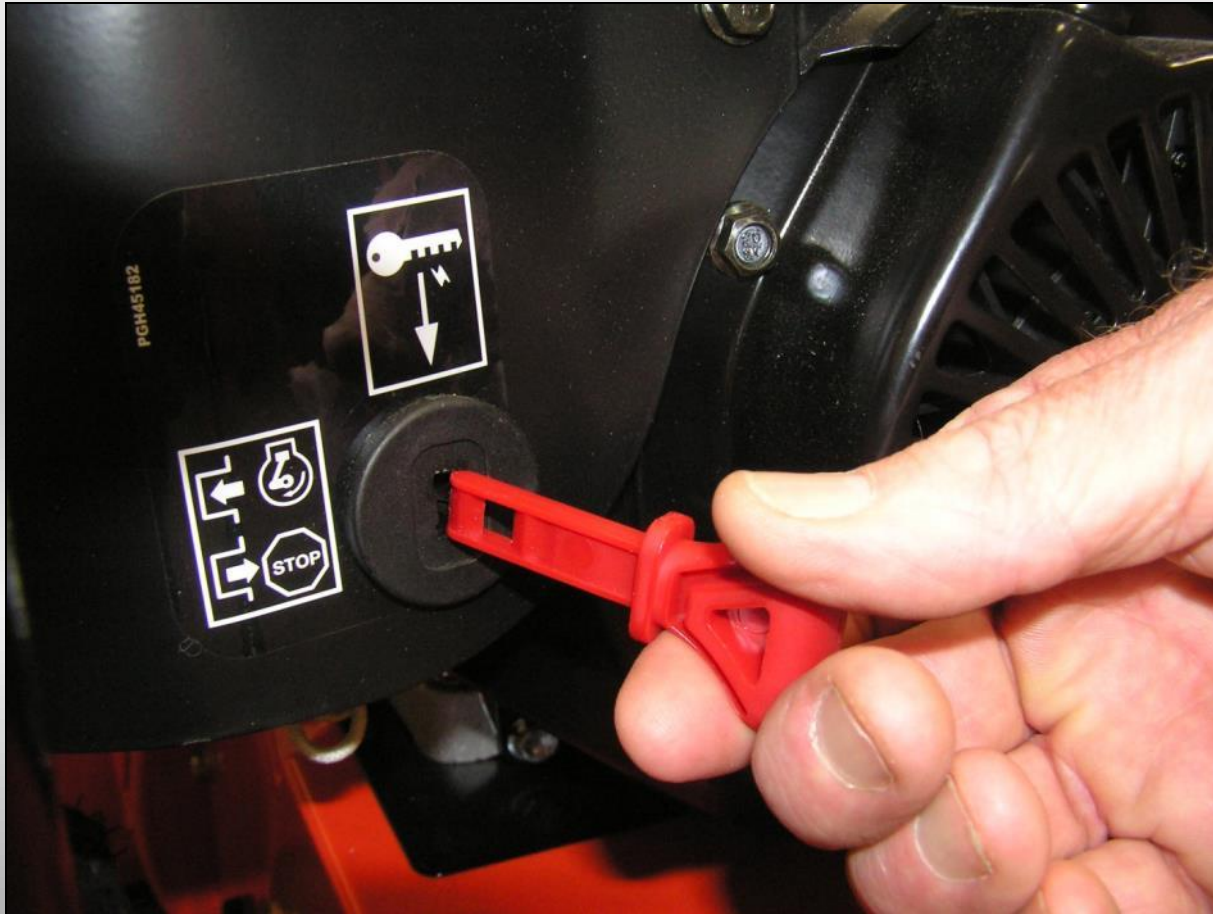

Install Safety Key Switch. Insert ignition key into slot but DO NOT turn the key. Be sure ignition key snaps into place.



## Starting Engine / Step E: Prime

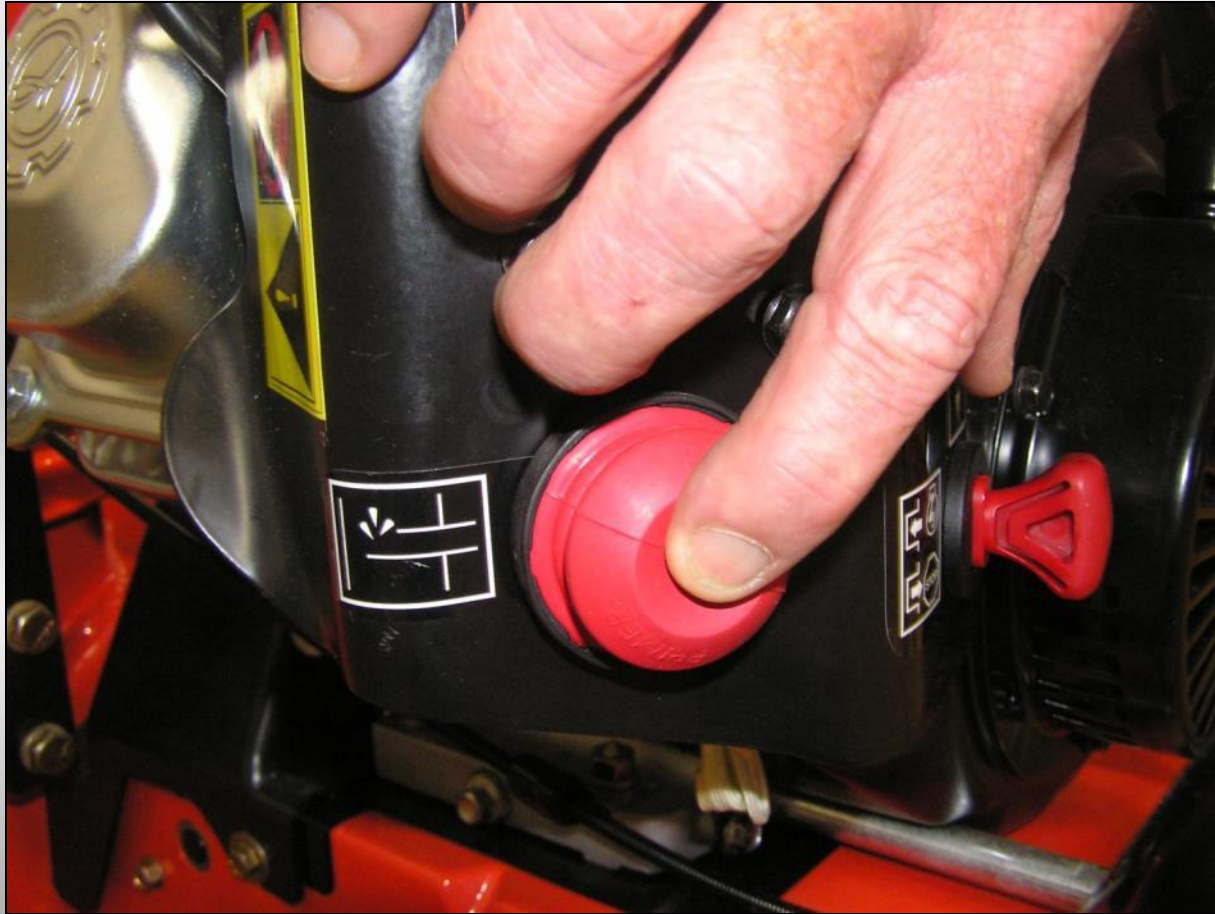

Prime system: 3 primes maximum. DO NOT over prime system. Make sure to cover the vent hole on primer bulb before the primer bulb is compressed. Hold the primer bulb in the compressed position for one full second each time you press it. Repeat for a total of 3 primes.



## Starting Engine / Step F: (Manual Start)



Grasp rope handle. Pull slowly until resistance is felt, then pull rope firmly and quickly to start engine and avoid kickback.



## Starting Engine / Step F: (Electric Start)



Use a 3-wire extension cord and plug cord into starter motor adaptor first. Then plug cord into wall receptacle. Use appropriately sized extension cord (10AWG or larger) to prevent damage to electric starter.



## Starting Engine / Step G: (Electric Start)



Press and hold starter button.

**Note:** Do not hold the electric starter button down for more than 5 seconds. Wait at least 1 minute before additional starting attempts.

## Starting Engine / Step H: Warm up



Allow the engine to warm up for 1-2 minutes, move the choke control to the **CHOKE OFF** position.



## Step Thirteen: Stopping the Engine (Ariens AX)

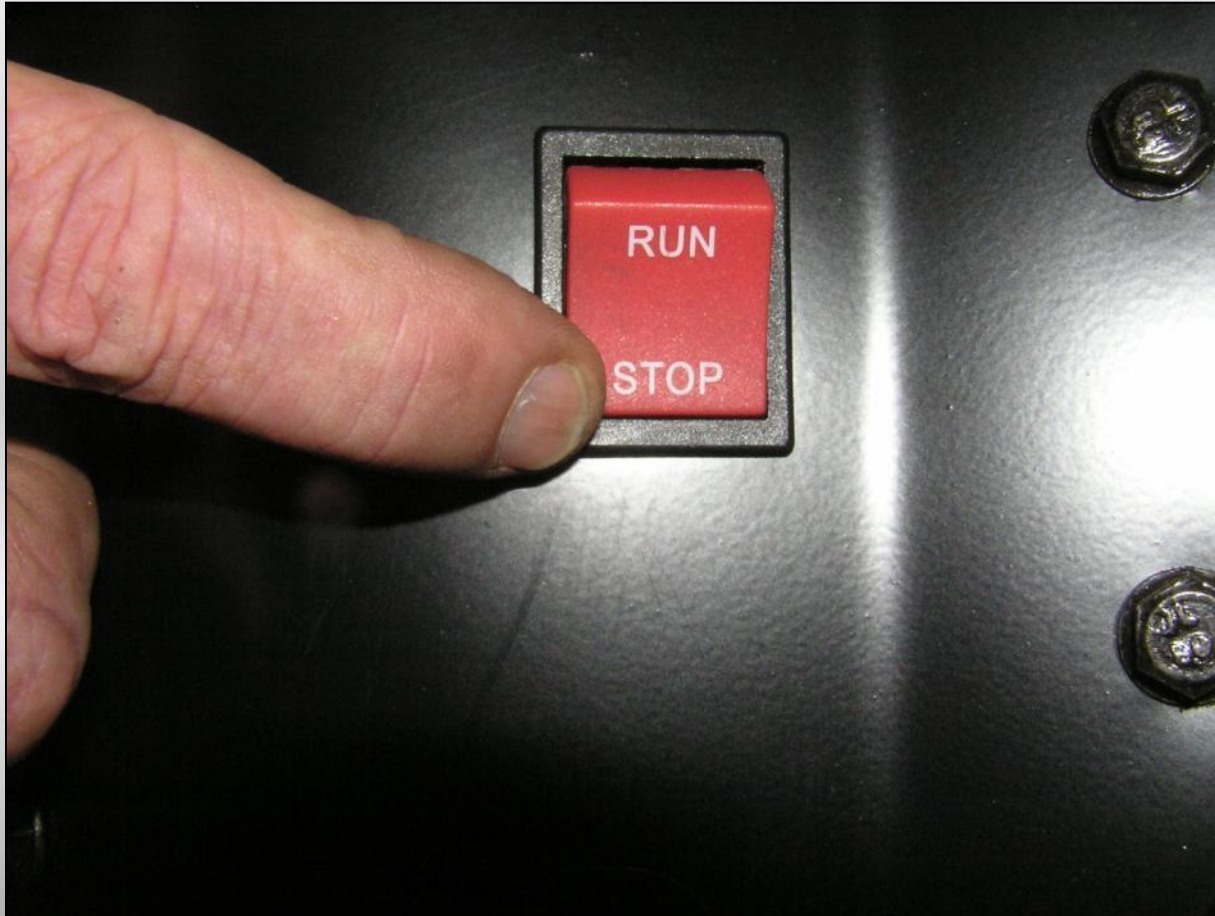

**To stop engine in an emergency, flip the Rocker Switch to the STOP position, OR Pull Safety Key from Engine.**

Under normal conditions:

1. Turn throttle down.
2. Push rocker switch to STOP position.
3. Pull safety key OUT.



# Additional Resources

- Refer to Owners Manual and Engine Manual
- Contact Ariens Company

[www.ariens.com](http://www.ariens.com)

Phone: 920-756-4688

E-mail: [info@ariens.com](mailto:info@ariens.com)